

Human Anti-IFN alpha ELISA Kit

Enzyme-linked Immunosorbent Assay for quantitative detection of human anti-IFN α

Catalog Numbers BMS217 and BMS217TEN

Pub. No. MAN0016569 **Rev.** A.0 (30)

WARNING! Read the Safety Data Sheets (SDSs) and follow the handling instructions. Wear appropriate protective eyewear, clothing, and gloves. Safety Data Sheets (SDSs) are available from thermofisher.com/support.

Product description

The Human Anti-IFN alpha ELISA Kit is an enzyme-linked immunosorbent assay for the quantitative detection of human anti-IFN α .

Summary

Studies on antigenicity led to the concept that molecules like the interferons were not immunogenic in homologous systems because antibodies are not normally produced against "self" antigens. However, naturally occurring or therapeutically induced antibodies to cytokines such as interferons, tumor necrosis factors (TNF), interleukins (IL), and various growth factors were found, which are generally thought to inhibit cytokine functions, and the appearance of such antibodies should therefore result in various degrees of cytokine deficiency. It is a common concept that the development of antibodies against any auto-antigen or drug is always undesirable. Such antibodies are crucial for the pathology of autoimmune diseases and inhibit the pharmacological effects of drugs including exogenously administered cytokines.

For literature update refer to our website.

Principles of the test

Recombinant human IFN α is adsorbed onto microwells.

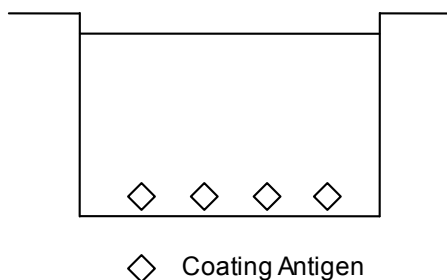

Fig. 1 Coated microwell

Human anti-IFN α present in the sample or standard binds to the capture protein adsorbed to the microwells.

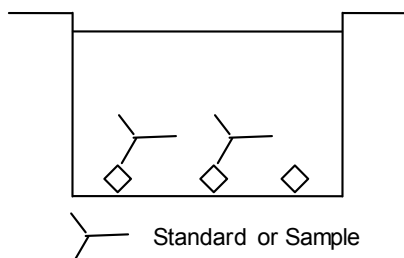

Fig. 2 First incubation

Following incubation unbound biological components are removed during a wash step and a HRP-conjugated human IFN α protein is added and binds to human anti-IFN α captured by the first human IFN α protein.

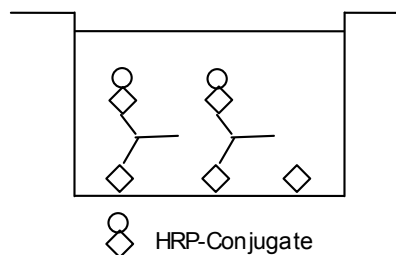

Fig. 3 Second incubation

Following incubation unbound HRP-conjugated human IFN α is removed during a wash step, and substrate solution reactive with HRP is added to the wells.

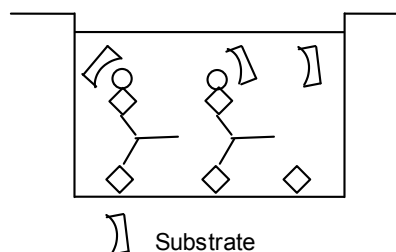

Fig. 4 Third incubation

A colored product is formed in proportion to the amount of human anti-IFN α present in the sample or standard. The reaction is terminated by addition of acid and absorbance is measured at 450 nm. A standard curve is prepared from 7 human anti-IFN α standard dilutions and human anti-IFN α concentration determined.

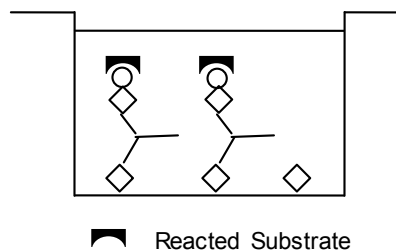

Fig. 5 Stop reaction

Reagents provided

- Reagents for human anti-IFN α ELISA BMS217 (96 tests)**
- 1 aluminum pouch with a Microwell Plate (12 strips of 8 wells each) coated with recombinant human IFN α
 - 1 vial (200 μ L) HRP-Conjugate human IFN α protein
 - 2 vials (500 μ L) human anti-IFN α Standard, 200 ng/mL

1 vial (5 mL) Assay Buffer Concentrate 20x (PBS with 1% Tween™ 20, 10% BSA)

1 bottle (50 mL) Wash Buffer Concentrate 20x (PBS with 1% Tween™ 20)

1 vial (15 mL) Substrate Solution (tetramethyl-benzidine)

1 vial (15 mL) Stop Solution (1M Phosphoric acid)

4 Adhesive Films

Reagents for human anti-IFN α ELISA BMS217TEN (10x96 tests)

10 aluminum pouches with a Microwell Plate (12 strips of 8 wells each) coated with recombinant human IFN α

10 vials (200 μ L) HRP-Conjugate human IFN α protein

10 vials (500 μ L) human anti-IFN α Standard, 200 ng/mL

3 vials (5 mL) Assay Buffer Concentrate 20x (PBS with 1% Tween™ 20, 10% BSA)

6 bottles (50 mL) Wash Buffer Concentrate 20x (PBS with 1% Tween™ 20)

10 vials (15 mL) Substrate Solution (tetramethyl-benzidine)

1 vial (100 mL) Stop Solution (1M Phosphoric acid)

20 Adhesive Films

Storage instructions – ELISA kit

Store kit reagents between 2° and 8°C. Immediately after use remaining reagents should be returned to cold storage (2° to 8°C). Expiry of the kit and reagents is stated on labels.

Expiry of the kit components can only be guaranteed if the components are stored properly, and if, in case of repeated use of one component, this reagent is not contaminated by the first handling.

Sample collection and storage instructions

Cell culture supernatant, serum, plasma (EDTA, citrate, heparin), and urine were tested with this assay. Other biological samples might be suitable for use in the assay.

Remove serum or plasma from the clot or cells as soon as possible after clotting and separation.

Samples containing a visible precipitate must be clarified prior to use in the assay. Do not use grossly hemolyzed or lipemic samples.

Samples should be aliquoted and must be stored frozen at -20°C to avoid loss of bioactive human anti-IFN α . If samples are to be run within 24 hours, they may be stored at 2-8°C (for sample stability refer to “Sample stability” on page 5).

Avoid repeated freeze-thaw cycles. Prior to assay, the frozen sample should be brought to room temperature slowly and mixed gently.

Materials required but not provided

- 5 mL and 10 mL graduated pipettes
- 5 μ L to 1000 μ L adjustable single channel micropipettes with disposable tips
- 50 μ L to 300 μ L adjustable multichannel micropipette with disposable tips
- Multichannel micropipette reservoir
- Beakers, flasks, cylinders necessary for preparation of reagents
- Device for delivery of wash solution (multichannel wash bottle or automatic wash system)
- Microwell strip reader capable of reading at 450 nm (620 nm as optional reference wave length)
- Glass-distilled or deionized water
- Statistical calculator with program to perform regression analysis

Precautions for use

- All chemicals should be considered as potentially hazardous. We therefore recommend that this product is handled only by those persons who have been trained in laboratory techniques and that it is used in accordance with the principles of good laboratory practice. Wear suitable protective clothing such as laboratory overalls, safety glasses and gloves. Care should be taken to avoid contact with skin or eyes. In the case of contact with skin or eyes wash immediately with water. See material safety data sheet(s) and/or safety statement(s) for specific advice.
- Reagents are intended for research use only and are not for use in diagnostic or therapeutic procedures.
- Do not mix or substitute reagents with those from other lots or other sources.
- Do not use kit reagents beyond expiration date on label.
- Do not expose kit reagents to strong light during storage or incubation.
- Do not pipet by mouth.
- Do not eat or smoke in areas where kit reagents or samples are handled.
- Avoid contact of skin or mucous membranes with kit reagents or samples.
- Rubber or disposable latex gloves should be worn while handling kit reagents or samples.
- Avoid contact of substrate solution with oxidizing agents and metal.
- Avoid splashing or generation of aerosols.
- To avoid microbial contamination or cross-contamination of reagents or samples that may invalidate the test, use disposable pipette tips and/or pipettes.
- Use clean, dedicated reagent trays for dispensing the conjugate and substrate reagent.
- Exposure to acid inactivates the conjugate.
- Glass-distilled water or deionized water must be used for reagent preparation.
- Substrate solution must be at room temperature prior to use.
- Decontaminate and dispose samples and all potentially contaminated materials as if they could contain infectious agents. The preferred method of decontamination is autoclaving for a minimum of 1 hour at 121.5°C.
- Liquid wastes not containing acid and neutralized waste may be mixed with sodium hypochlorite in volumes such that the final mixture contains 1.0% sodium hypochlorite. Allow 30 minutes for effective decontamination. Liquid waste containing acid must be neutralized prior to the addition of sodium hypochlorite.

Preparation of reagents

1. Buffer Concentrates should be brought to room temperature and should be diluted before starting the test procedure.
2. If crystals have formed in the Buffer Concentrates, warm them gently until they have completely dissolved.

Wash buffer (1x)

1. Pour entire contents (50 mL) of the Wash Buffer Concentrate (20x) into a clean 1000 mL graduated cylinder. Bring to final volume of 1000 mL with glass-distilled or deionized water. Mix gently to avoid foaming.
2. Transfer to a clean wash bottle and store at 2° to 25°C. Please note that Wash Buffer (1x) is stable for 30 days.
3. Wash Buffer (1x) may also be prepared as needed according to the following table:

Number of Strips	Wash Buffer Concentrate (20x) (mL)	Distilled Water (mL)
1 - 6	25	475
1 - 12	50	950

Assay buffer (1x)

1. Pour the entire contents (5 mL) of the Assay Buffer Concentrate (20x) into a clean 100 mL graduated cylinder. Bring to final volume of 100 mL with distilled water. Mix gently to avoid foaming.
2. Store at 2° to 8°C. Please note that the Assay Buffer (1x) is stable for 30 days.
3. Assay Buffer (1x) may also be prepared as needed according to the following table:

Number of Strips	Assay Buffer Concentrate (20x) (mL)	Distilled Water (mL)
1 - 6	2.5	47.5
1 - 12	5.0	95.0

HRP-Conjugate

Note: The HRP-Conjugate should be used within 30 minutes after dilution.

Make a 1:100 dilution of the concentrated HRP-Conjugate solution with Assay Buffer (1x) in a clean plastic tube as needed according to the following table:

Number of Strips	HRP-Conjugate (mL)	Assay Buffer (1x) (mL)
1 - 6	0.06	5.94
1 - 12	0.12	11.88

Human anti-IFN α standard

Standard dilutions can be prepared directly on the microwell plate (see "Test protocol" on page 3) or alternatively in tubes (see "External standard dilution" on page 3).

External standard dilution

1. Label 6 tubes, one for each standard point: S2, S3, S4, S5, S6, S7.
2. Prepare 1:2 serial dilutions for the standard curve as follows: Pipette 225 μ L of Assay Buffer (1x) into each tube.
3. Pipette 225 μ L of undiluted standard (serves as the highest standard S1, concentration of standard 1 = 200 ng/mL) into the first tube, labeled S2, and mix (concentration of standard 2 = 100 ng/mL).
4. Pipette 225 μ L of this dilution into the second tube, labeled S3, and mix thoroughly before the next transfer.
5. Repeat serial dilutions 4 more times thus creating the points of the standard curve (see Figure 6).

Assay Buffer (1x) serves as blank.

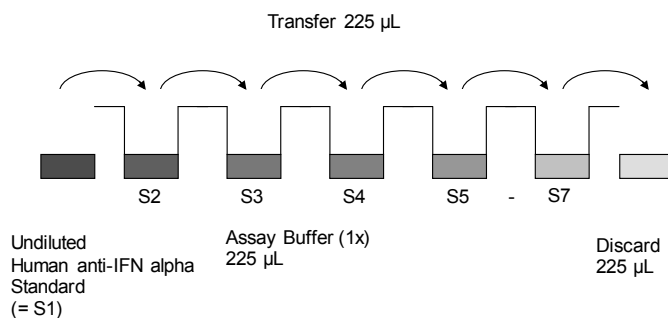

Fig. 6 Dilute standards - tubes

Test protocol

Note: In case of incubation without shaking the obtained O.D. values may be lower than indicated below. Nevertheless the results are still valid.

1. Determine the number of microwell strips required to test the desired number of samples plus appropriate number of wells needed for running blanks and standards. Each sample, standard, blank and optional control sample should be assayed in duplicate. Remove extra microwell strips from holder and store in foil bag with the desiccant provided at 2–8°C sealed tightly.
2. Wash the microwell strips twice with approximately 400 μ L Wash Buffer per well with thorough aspiration of microwell contents between washes. Allow the Wash Buffer to sit in the wells for about 10–15 seconds before aspiration. Take care not to scratch the surface of the microwells.
3. Standard dilution on the microwell plate (alternatively, the standard dilution can be prepared in tubes, see "External standard dilution" on page 3):

Add 100 μ L of Assay Buffer (1x) in duplicate to standard wells B1/B2-G1/G2, leaving A1/A2 empty. Pipette 200 μ L of undiluted standard (concentration = 200.0 ng/mL) in duplicate into well A1 and A2 (see Table 1). Transfer 100 μ L to wells B1 and B2. Mix the contents of wells B1 and B2 by repeated aspiration and ejection, and transfer 100 μ L to wells C1 and C2, respectively. (see Figure 7). Take care not to scratch the inner surface of the microwells. Continue this procedure 4 times, creating two rows of human anti-IFN α standard dilutions ranging from 200.0 to 3.1 ng/mL. Discard 100 μ L of the contents from the last microwells (G1, G2) used.

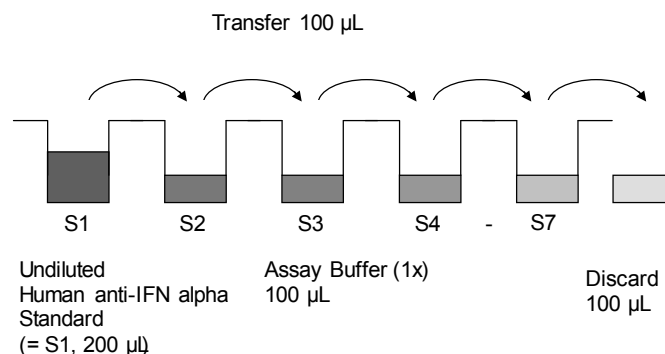

Fig. 7 Dilute standards - microwell plate.

Table 1 Example of the arrangement of blanks, standards, and samples in the microwell strips.

	1	2	3	4
A	Standard 1 200.0 ng/mL	Standard 1 200.0 ng/mL	Sample 1	Sample 1
B	Standard 2 100.0 ng/mL	Standard 2 100.0 ng/mL	Sample 2	Sample 2
C	Standard 3 50.0 ng/mL	Standard 3 50.0 ng/mL	Sample 3	Sample 3
D	Standard 4 25.0 ng/mL	Standard 4 25.0 ng/mL	Sample 4	Sample 4
E	Standard 5 12.5 ng/mL	Standard 5 12.5 ng/mL	Sample 5	Sample 5
F	Standard 6 6.3 ng/mL	Standard 6 6.3 ng/mL	Sample 6	Sample 6
G	Standard 7 3.1 ng/mL	Standard 7 3.1 ng/mL	Sample 7	Sample 7
H	Blank	Blank	Sample 8	Sample 8

In case of an external standard dilution (see “External standard dilution” on page 3), pipette 100 µL of these standard dilutions (S1–S7) in the standard wells according to Table 1.

4. Add 100 µL of Assay Buffer (1x) in duplicate to the blank wells.
5. Add 80 µL of Assay Buffer (1x) to the sample wells.
6. Add 20 µL of each sample in duplicate to the sample wells.
7. Cover with an adhesive film and incubate at room temperature (18–25°C) for 2 hours on a microplate shaker.
8. Prepare HRP-Conjugate (see “HRP-Conjugate” on page 3).
9. Remove adhesive film and empty wells. Wash microwell strips 6 times according to point 2 of the test protocol. Proceed immediately to the next step.
10. Add 100 µL of HRP-Conjugate to all wells.
11. Cover with an adhesive film and incubate at room temperature (18–25°C) for 1 hour on a microplate shaker.
12. Remove adhesive film and empty wells. Wash microwell strips 6 times according to point 2 of the test protocol. Proceed immediately to the next step.
13. Pipette 100 µL of TMB Substrate Solution to all wells.
14. Incubate the microwell strips at room temperature (18–25°C) for about 10 minutes. Avoid direct exposure to intense light.

The color development on the plate should be monitored and the substrate reaction stopped (see next point of this protocol) before positive wells are no longer properly recordable. Determination of the ideal time period for color development has to be done individually for each assay.

It is recommended to add the stop solution when the highest standard has developed a dark blue color. Alternatively the color development can be monitored by the ELISA reader at 620 nm. The substrate reaction should be stopped as soon as Standard 1 has reached an OD of 0.9–0.95.

15. Stop the enzyme reaction by quickly pipetting 100 µL of Stop Solution into each well. It is important that the Stop Solution is spread quickly and uniformly throughout the microwells to completely inactivate the enzyme. Results must be read immediately after the Stop Solution is added or within one hour if the microwell strips are stored at 2–8°C in the dark.
16. Read absorbance of each microwell on a spectro-photometer using 450 nm as the primary wave length (optionally 620 nm as the reference wave length; 610 nm to 650 nm is acceptable). Blank the plate reader according to the manufacturer’s instructions by using the blank wells. Determine the absorbance of both the samples and the standards.

Calculation of results

- Calculate the average absorbance values for each set of duplicate standards and samples. Duplicates should be within 20 percent of the mean value.
- Create a standard curve by plotting the mean absorbance for each standard concentration on the ordinate against the human anti-IFN α concentration on the abscissa. Draw a best fit curve through the points of the graph (a 5-parameter curve fit is recommended).
- To determine the concentration of circulating human anti-IFN α for each sample, first find the mean absorbance value on the ordinate and extend a horizontal line to the standard curve. At the point of intersection, extend a vertical line to the abscissa and read the corresponding human anti-IFN α concentration.
- If instructions in this protocol have been followed, samples have been diluted 1:5 (20 µL sample + 80 µL Assay Buffer (1x)) and the concentration read from the standard curve must be multiplied by the dilution factor (× 5).
- Calculation of samples with a concentration exceeding standard 1 may result in incorrect human anti-IFN α levels. Such samples require further external predilution according to expected human anti-IFN α values with Assay Buffer (1x) in order to precisely quantitate the actual human anti-IFN α level.

- It is suggested that each testing facility establishes a control sample of known human anti-IFN α concentration and runs this additional control with each assay. If the values obtained are not within the expected range of the control, the assay results may be invalid.
- A representative standard curve is shown in Figure 8.

Note: Do not use this standard curve to derive test results. Each laboratory must prepare a standard curve for each group of microwell strips assayed.

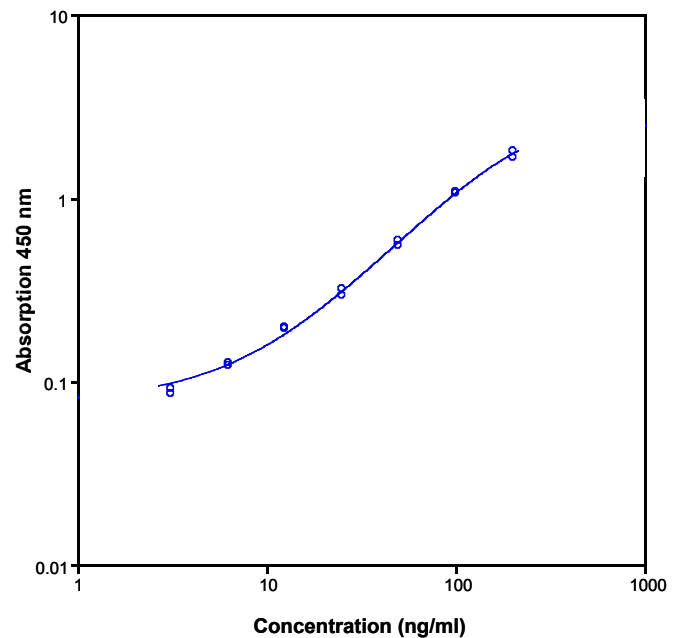

Fig. 8 Representative standard curve for human anti-IFN α ELISA. Human anti-IFN α was diluted in serial 2-fold steps in Assay Buffer (1x).

Table 2 Typical data using the human anti-IFN α ELISA.

Measuring wavelength: 450 nm

Reference wavelength: 620 nm

Standard	Human anti-IFN α concentration (ng/mL)	O.D. at 450 nm	Mean O.D. at 450 nm	C.V. (%)
1	200.0	1.670	1.737	3.8
	200.0	1.803		
2	100.0	1.061	1.066	0.5
	100.0	1.071		
3	50.0	0.546	0.567	3.7
	50.0	0.588		
4	25.0	0.321	0.308	4.4
	25.0	0.294		
5	12.5	0.195	0.197	0.8
	12.5	0.198		
6	6.3	0.122	0.124	1.2
	6.3	0.125		
7	3.1	0.085	0.089	4.0
	3.1	0.092		
Blank	0	0.050	0.049	2.0
	0	0.048		

The OD values of the standard curve may vary according to the conditions of assay performance (e.g., operator, pipetting technique, washing technique, or temperature effects). Furthermore shelf life of the kit may affect enzymatic activity and thus color intensity. Values measured are still valid.

Limitations

- Since exact conditions may vary from assay to assay, a standard curve must be established for every run.
- Bacterial or fungal contamination of either screen samples or reagents or cross-contamination between reagents may cause erroneous results.
- Disposable pipette tips, flasks or glassware are preferred, reusable glassware must be washed and thoroughly rinsed of all detergents before use.
- Improper or insufficient washing at any stage of the procedure will result in either false positive or false negative results. Empty wells completely before dispensing fresh wash solution, fill with Wash Buffer as indicated for each wash cycle and do not allow wells to sit uncovered or dry for extended periods.

Performance characteristics

Sensitivity

The limit of detection of human anti-IFN α defined as the analyte concentration resulting in an absorbance significantly higher than that of the dilution medium (mean plus 2 standard deviations) was determined to be 1.4 ng/mL (mean of 6 independent assays).

Reproducibility

Intra-assay

Reproducibility within the assay was evaluated in 3 independent experiments. Each assay was carried out with 6 replicates of 8 serum samples (spiked and unspiked) containing different concentrations of human anti-IFN α . Two standard curves were run on each plate. Data below show the mean human anti-IFN α concentration and the coefficient of variation for each sample (see Table 3). The calculated overall intra-assay coefficient of variation was 3.3%.

Table 3 The mean human anti-IFN α concentration and the coefficient of variation for each sample.

Sample	Experiment	Mean human anti-IFN α concentration (ng/mL)	Coefficient of variation (%)
1	1	801.5	0.5
	2	769.1	2.5
	3	769.6	4.8
2	1	494.8	4.5
	2	533.6	3.4
	3	512.8	1.6
3	1	384.9	3.1
	2	365.9	3.2
	3	397.7	1.4
4	1	136.1	3.2
	2	132.8	3.4
	3	143.5	2.0
5	1	67.1	1.1
	2	64.8	2.8
	3	70.8	4.4
6	1	81.1	6.8
	2	79.9	4.1
	3	88.1	5.5
7	1	47.5	1.1
	2	47.4	5.1
	3	48.6	2.5
8	1	43.3	4.5
	2	42.6	2.7
	3	48.3	4.7

Inter-assay

Assay to assay reproducibility within one laboratory was evaluated in 3 independent experiments. Each assay was carried out with 6 replicates of 8 serum samples (spiked and unspiked) containing different concentrations of human anti-IFN α . Two standard curves were run on each plate. Data below show the mean human anti-IFN α

concentration and the coefficient of variation calculated on 18 determinations of each sample (see Table 4). The calculated overall inter-assay coefficient of variation was 4.1%.

Table 4 The mean human anti-IFN α concentration and the coefficient of variation of each sample.

Sample	Mean human anti-IFN α concentration (ng/mL)	Coefficient of variation (%)
1	780.1	2.4
2	513.7	3.8
3	382.8	4.2
4	137.5	4.0
5	67.6	4.5
6	83.0	5.4
7	47.8	1.4
8	44.8	7.0

Spike recovery

The spike recovery was evaluated by spiking 4 levels of human anti-IFN α into pooled normal human serum samples. Recoveries were determined in 3 independent experiments with 6 replicates each. The unspiked serum was used as blank in these experiments. The recovery ranged from 84% to 98% with an overall mean recovery of 92%. Spiking in individual patient sera may result in lower recoveries.

Dilution parallelism

Four spiked and one unspiked serum samples with different levels of human anti-IFN α were analyzed at serial 2-fold dilutions with 4 replicates each. The recovery ranged from 99% to 113% with an overall recovery of 104%.

Sample	Dilution	Expected human anti-IFN α concentration (ng/mL)	Observed human anti-IFN α concentration (ng/mL)	Recovery of expected human anti-IFN α concentration (%)
1	1:5	–	506.8	–
	1:10	253.4	255.4	101
	1:20	127.7	131.6	103
2	1:5	–	324.2	–
	1:10	162.1	169.5	105
	1:20	84.8	88.4	104
3	1:5	–	210.6	–
	1:10	105.3	103.7	99
	1:20	51.9	53.7	104
4	1:5	–	116.9	–
	1:10	58.4	61.9	106
	1:20	31.0	32.3	104
5	1:5	–	381.6	–
	1:10	190.8	194.7	102
	1:20	97.4	110.3	113
	1:40	55.2	54.5	99

Sample stability

Freeze-Thaw stability

Aliquots of spiked serum samples were stored at -20°C and thawed 5 times, and the human anti-IFN α levels determined. A significant decrease of human anti-IFN α immunoreactivity (10%) was detected. Therefore samples should be stored in aliquots at -20°C and thawed only once.

Storage stability

Aliquots of spiked serum samples were stored at -20°C, 2–8°C, room temperature, and at 37°C, and the human anti-IFN α level determined after 24 hours. There was no significant loss of human anti-IFN α immunoreactivity detected during storage under above conditions.

Specificity

The assay detects human antibodies to IFN α . To define the specificity of this ELISA several human immunoglobulins to different polypeptides were tested for cross reactivity. No cross-reactivity detected.

Expected values

A panel of 57 serum samples from randomly selected apparently healthy donors (males and females) and patients suffering from various diseases was tested for human anti-IFN α . The detected human anti-IFN α levels ranged between 0 and 120.5 ng/mL with a mean level of 17.4 ng/mL and a standard deviation of 26.7 ng/mL.

Reagent preparation summary

Wash buffer (1x)

Add Wash Buffer Concentrate 20x (50 mL) to 950 mL distilled water.

Number of Strips	Wash Buffer Concentrate (mL)	Distilled Water (mL)
1 - 6	25	475
1 - 12	50	950

Assay buffer (1x)

Add Assay Buffer Concentrate 20x (5 mL) to 95 mL distilled water.

Number of Strips	Assay Buffer Concentrate (mL)	Distilled Water (mL)
1 - 6	2.5	47.5
1 - 12	5.0	95.0

HRP-Conjugate

Make a 1:100 dilution of HRP-Conjugate in Assay Buffer (1x):

Number of Strips	HRP-Conjugate (mL)	Assay Buffer (1x) (mL)
1 - 6	0.06	5.94
1 - 12	0.12	11.88

Test protocol summary

Note: If instructions in this protocol have been followed, samples have been diluted 1:5 (20 μ L sample + 80 μ L Assay Buffer (1x)) and the concentration read from the standard curve must be multiplied by the dilution factor (x 5).

1. Determine the number of microwell strips required.
2. Wash microwell strips twice with Wash Buffer.
3. Standard dilution on the microwell plate: Add 100 μ L Assay Buffer (1x), in duplicate, to all standard wells leaving the first wells empty. Pipette 200 μ L standard into the first wells and create standard dilutions by transferring 100 μ L from well to well. Discard 100 μ L from the last wells.

Alternatively, external standard dilution in tubes (see "External standard dilution" on page 3): Pipette 100 μ L of these standard dilutions in the microwell strips.

4. Add 100 μ L Assay Buffer (1x), in duplicate, to the blank wells.
5. Add 80 μ L Assay Buffer (1x) to sample wells.
6. Add 20 μ L sample in duplicate, to designated sample wells.
7. Cover microwell strips and incubate 2 hours at room temperature (18–25°C).
8. Prepare HRP-Conjugate.
9. Empty and wash microwell strips 6 times with Wash Buffer.
10. Add 100 μ L HRP-Conjugate to all wells.
11. Cover microwell strips and incubate 1 hour at room temperature (18–25°C).
12. Empty and wash microwell strips 6 times with Wash Buffer.
13. Add 100 μ L of TMB Substrate Solution to all wells.
14. Incubate the microwell strips for about 10 minutes at room temperature (18–25°C).
15. Add 100 μ L Stop Solution to all wells.
16. Blank microwell reader and measure color intensity at 450 nm.

Customer and technical support

Visit thermofisher.com/support for the latest service and support information.

- Worldwide contact telephone numbers
- Product support information
 - Product FAQs
 - Software, patches, and updates
 - Training for many applications and instruments
- Order and web support
- Product documentation
 - User guides, manuals, and protocols
 - Certificates of Analysis
 - Safety Data Sheets (SDSs; also known as MSDSs)

Note: For SDSs for reagents and chemicals from other manufacturers, contact the manufacturer.

Limited product warranty

Life Technologies Corporation and/or its affiliate(s) warrant their products as set forth in the Life Technologies' General Terms and Conditions of Sale at www.thermofisher.com/us/en/home/global/terms-and-conditions.html. If you have any questions, please contact Life Technologies at www.thermofisher.com/support.



Bender MedSystems GmbH | Campus Vienna Biocenter 2 | 1030 Vienna, Austria
For descriptions of symbols on product labels or product documents, go to thermofisher.com/symbols-definition.

The information in this guide is subject to change without notice.

DISCLAIMER: TO THE EXTENT ALLOWED BY LAW, THERMO FISHER SCIENTIFIC INC. AND/OR ITS AFFILIATE(S) WILL NOT BE LIABLE FOR SPECIAL, INCIDENTAL, INDIRECT, PUNITIVE, MULTIPLE, OR CONSEQUENTIAL DAMAGES IN CONNECTION WITH OR ARISING FROM THIS DOCUMENT, INCLUDING YOUR USE OF IT.

Important Licensing Information: These products may be covered by one or more Limited Use Label Licenses. By use of these products, you accept the terms and conditions of all applicable Limited Use Label Licenses.

©2018 Thermo Fisher Scientific Inc. All rights reserved. All trademarks are the property of Thermo Fisher Scientific and its subsidiaries unless otherwise specified. All other trademarks are the property of their respective owners.

thermofisher.com/support | thermofisher.com/askaquestion

thermofisher.com

ThermoFisher
SCIENTIFIC