

# Mouse IL-17F ELISA Kit

Enzyme-linked Immunosorbent Assay for quantitative detection of mouse IL-17F

**Catalog Numbers** BMS6020 or BMS6020TEN

**Pub. No.** MAN0016877 **Rev.** A.0 (30)

**WARNING!** Read the Safety Data Sheets (SDSs) and follow the handling instructions. Wear appropriate protective eyewear, clothing, and gloves. Safety Data Sheets (SDSs) are available from [thermofisher.com/support](http://thermofisher.com/support).

## Product description

The Mouse IL-17F ELISA Kit is an enzyme-linked immunosorbent assay for the quantitative detection of mouse IL-17F.

## Summary

Interleukins 17F (IL-17F) and 17A (IL-17A) are closely related members of the IL-17 cytokine family, sharing about 50% amino acid identity. Studies in the mouse have identified Th17 cells as a distinct CD4+ T cell lineage that is defined by the production of IL-17F and IL-17A. IL-6 and transforming growth factor  $\beta$  are required for the differentiation of naïve CD4+ T cells to Th17 cells, which are maintained in the presence of IL-23 and IL-1  $\beta$ . Conversely, IL-4 and interferon- $\gamma$  can inhibit the development of Th17 cells. Th17 cells have been implicated in the pathology of mouse autoimmune disease models.

Expression of IL-17F and IL-17A has been detected in activated human peripheral blood lymphocytes. It has been shown that the cytokines are expressed in activated human CD4+ T cells. Expression of IL-17F and IL-17A has also been observed in tissue samples from various autoimmune diseases such as rheumatoid arthritis, multiple sclerosis, psoriasis, inflammatory bowel disease, and asthma.

The crystal structure of IL-17F has been solved and shows that the protein forms a disulfide-linked dimeric glycoprotein. IL-17A is also a disulfide-linked homodimeric glycoprotein. The IL-17F homodimer includes a classical cysteine knot motif, which is found in the TGF  $\beta$ , bone morphogenetic protein, and nerve growth factor superfamilies. One difference in the cysteine knot motif of IL-17F compared with the other known cysteine knot protein families is that it only utilizes four cysteines instead of the classical six cysteines to form the knot. IL-17F and IL-17A have been shown to form biologically active IL-17F/IL-17A heterodimers, in addition to the IL-17F and IL-17A homodimers.

For literature update, refer to our website.

## Principles of the test

An anti-mouse IL-17F coating antibody is adsorbed onto microwells.

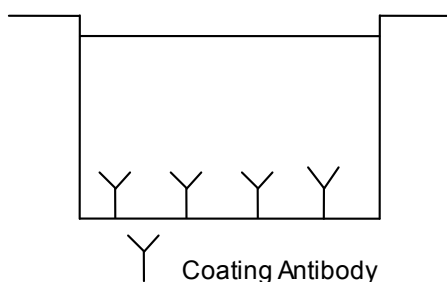

Fig. 1 Coated microwell

Mouse IL-17F present in the sample or standard binds to antibodies adsorbed to the microwells.

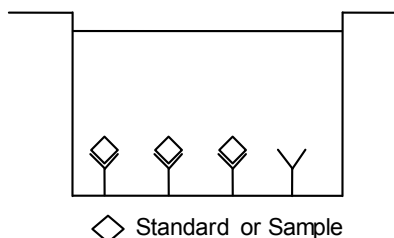

Fig. 2 First incubation

Following incubation unbound biological components are removed during a wash step and a biotin-conjugated anti-mouse IL-17F antibody is added and binds to mouse IL-17F captured by the first antibody.

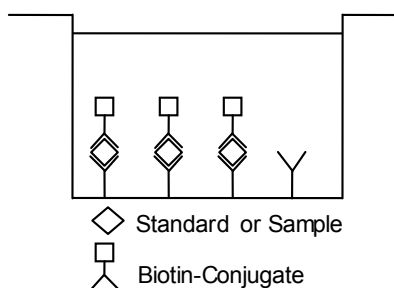

Fig. 3 Second incubation

Following incubation unbound biotin-conjugated anti-mouse IL-17F antibody is removed during a wash step. Streptavidin-HRP is added and binds to the biotin-conjugated anti-mouse IL-17F antibody.

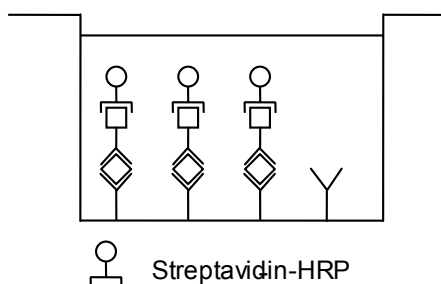

Fig. 4 Third incubation

Following incubation unbound Streptavidin-HRP is removed during a wash step, and substrate solution reactive with HRP is added to the wells.

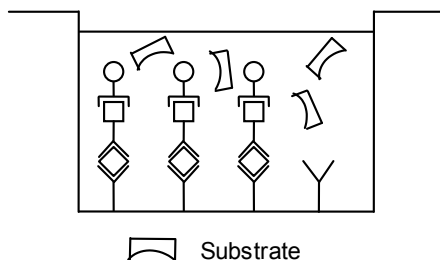

Fig. 5 Fourth incubation

A colored product is formed in proportion to the amount of mouse IL-17F present in the sample or standard. The reaction is terminated by addition of acid and absorbance is measured at 450 nm. A standard curve is prepared from 7 mouse IL-17F standard dilutions and mouse IL-17F sample concentration determined.

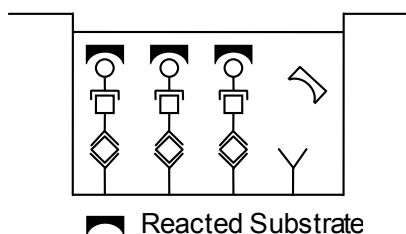

Fig. 6 Stop reaction

## Reagents provided

### Reagents for mouse IL-17F ELISA BMS6020 (96 tests)

1 aluminum pouch with a Microwell Plate (12 strips of 8 wells each) coated with monoclonal antibody to mouse IL-17F

1 vial (120  $\mu$ L) Biotin-Conjugate anti-mouse IL-17F polyclonal antibody

1 vial (150  $\mu$ L) Streptavidin-HRP

2 vials mouse IL-17F Standard lyophilized, 4 ng/mL upon reconstitution

1 vial (12 mL) Sample Diluent

1 vial (15 mL) Conjugate Diluent

1 vial (5 mL) Assay Buffer Concentrate 20x (PBS with 1% Tween 20, 10% BSA)

1 bottle (50 mL) Wash Buffer Concentrate 20x (PBS with 1% Tween 20)

1 bottle (5 mL) Calibrator Diluent

1 vial (15 mL) Substrate Solution (tetramethyl-benzidine)

1 vial (15 mL) Stop Solution (1M Phosphoric acid)

6 Adhesive Films

### Reagents for mouse IL-17F ELISA BMS6020TEN (10x96 tests)

10 aluminum pouches with a Microwell Plate (12 strips of 8 wells each) coated with monoclonal antibody to mouse IL-17F

10 vials (120  $\mu$ L) Biotin-Conjugate anti-mouse IL-17F polyclonal antibody

10 vials (150  $\mu$ L) Streptavidin-HRP

10 vials mouse IL-17F Standard lyophilized, 4 ng/mL upon reconstitution

6 vials (12 mL) Sample Diluent

10 vials (15 mL) Conjugate Diluent

2 vials (5 mL) Assay Buffer Concentrate 20x (PBS with 1% Tween 20, 10% BSA)

8 bottles (50 mL) Wash Buffer Concentrate 20x (PBS with 1% Tween 20)

5 bottles (5 mL) Calibrator Diluent

10 vials (15 mL) Substrate Solution (tetramethyl-benzidine)

1 vial (100 mL) Stop Solution (1M Phosphoric acid)

## Storage instructions – ELISA kit

Store kit reagents between 2° and 8°C. Immediately after use remaining reagents should be returned to cold storage (2° to 8°C). Expiry of the kit and reagents is stated on labels.

Expiry of the kit components can only be guaranteed if the components are stored properly, and if, in case of repeated use of one component, this reagent is not contaminated by the first handling.

## Sample collection and storage instructions

Cell culture supernatant, serum and plasma (EDTA) were tested with this assay. Other biological samples might be suitable for use in the assay. Remove serum or plasma from the clot or cells as soon as possible after clotting and separation.

Samples containing a visible precipitate must be clarified prior to use in the assay. Do not use grossly hemolyzed or lipemic specimens.

Samples should be aliquoted and must be stored frozen at -20°C to avoid loss of bioactive mouse IL-17F. If samples are to be run within 24 hours, they may be stored at 2° to 8°C (refer to "Sample stability" on page 6).

Avoid repeated freeze-thaw cycles. Prior to assay, the frozen sample should be brought to room temperature slowly and mixed gently.

## Materials required but not provided

- 5 mL and 10 mL graduated pipettes
- 5  $\mu$ L to 1000  $\mu$ L adjustable single channel micropipettes with disposable tips
- 50  $\mu$ L to 300  $\mu$ L adjustable multichannel micropipette with disposable tips
- Multichannel micropipette reservoir
- Beakers, flasks, cylinders necessary for preparation of reagents
- Device for delivery of wash solution (multichannel wash bottle or automatic wash system)
- Microwell strip reader capable of reading at 450 nm (620 nm as optional reference wave length)
- Glass-distilled or deionized water
- Statistical calculator with program to perform regression analysis

## Precautions for use

- All reagents should be considered as potentially hazardous. We therefore recommend that this product is handled only by those persons who have been trained in laboratory techniques and that it is used in accordance with the principles of good laboratory practice. Wear suitable protective clothing such as laboratory overalls, safety glasses, and gloves. Care should be taken to avoid contact with skin or eyes. In the case of contact with skin or eyes wash immediately with water. See material safety data sheet(s) and/or safety statement(s) for specific advice.
- Reagents are intended for research use only and are not for use in diagnostic or therapeutic procedures.
- Do not mix or substitute reagents with those from other lots or other sources.
- Do not use kit reagents beyond expiration date on label.
- Do not expose kit reagents to strong light during storage or incubation.
- Do not pipet by mouth.
- Do not eat or smoke in areas where kit reagents or samples are handled.
- Avoid contact of skin or mucous membranes with kit reagents or samples.
- Rubber or disposable latex gloves should be worn while handling kit reagents or samples.
- Avoid contact of substrate solution with oxidizing agents and metal.
- Avoid splashing or generation of aerosols.

- To avoid microbial contamination or cross-contamination of reagents or samples that may invalidate the test, use disposable pipette tips and/or pipettes.
- Use clean, dedicated reagent trays for dispensing the conjugate and substrate reagent.
- Exposure to acid inactivates the conjugate.
- Glass-distilled water or deionized water must be used for reagent preparation.
- Substrate solution must be at room temperature prior to use.
- Decontaminate and dispose samples and all potentially contaminated materials as if they could contain infectious agents. The preferred method of decontamination is autoclaving for a minimum of 1 hour at 121.5°C.
- Liquid wastes not containing acid and neutralized waste may be mixed with sodium hypochlorite in volumes such that the final mixture contains 1.0% sodium hypochlorite. Allow 30 minutes for effective decontamination. Liquid waste containing acid must be neutralized prior to the addition of sodium hypochlorite.

## Preparation of reagents

- Buffer Concentrates should be brought to room temperature and should be diluted before starting the test procedure.
- If crystals have formed in the Buffer Concentrates, warm them gently until they have completely dissolved.

## Wash buffer (1x)

- Pour entire contents (50 mL) of the Wash Buffer Concentrate (20x) into a clean 1000 mL graduated cylinder. Bring to final volume of 1000 mL with glass-distilled or deionized water. Mix gently to avoid foaming.
- Transfer to a clean wash bottle and store at 2° to 25°C. Please note that Wash Buffer (1x) is stable for 30 days.
- Wash Buffer (1x) may also be prepared as needed according to the following table:

Number of Strips	Wash Buffer Concentrate (20x) (mL)	Distilled Water (mL)
1 - 6	25	475
1 - 12	50	950

## Assay buffer (1x)

- Pour the entire contents (5 mL) of the Assay Buffer Concentrate (20x) into a clean 100 mL graduated cylinder. Bring to final volume of 100 mL with distilled water. Mix gently to avoid foaming.
- Store at 2° to 8°C. Please note that the Assay Buffer (1x) is stable for 30 days.
- Assay Buffer (1x) may also be prepared as needed according to the following table:

Number of Strips	Assay Buffer Concentrate (20x) (mL)	Distilled Water (mL)
1 - 6	2.5	47.5
1 - 12	5.0	95.0

## Biotin-Conjugate

**Note:** The Biotin-Conjugate should be used within 30 minutes after dilution.

Make a 1:100 dilution of the concentrated Biotin-Conjugate solution with Conjugate Diluent in a clean plastic tube as needed according to the following table:

Number of Strips	Biotin-Conjugate (mL)	Conjugate Diluent (mL)
1 - 6	0.06	5.94
1 - 12	0.12	11.88

## Streptavidin-HRP

**Note:** The Streptavidin-HRP should be used within 30 minutes after dilution.

Make a 1:100 dilution of the concentrated Streptavidin-HRP solution with Assay Buffer (1x) in a clean plastic tube as needed according to the following table:

Number of Strips	Streptavidin-HRP (mL)	Assay Buffer (1x) (mL)
1 - 6	0.06	5.94
1 - 12	0.12	11.88

## Mouse IL-17F standard

- Reconstitute mouse IL-17F standard by addition of Calibrator Diluent. Reconstitution volume is stated on the label of the standard vial. Swirl or mix gently to insure complete and homogeneous solubilization (concentration of reconstituted standard = 4 ng/mL).
- Allow the standard to reconstitute for 10-30 minutes. Mix well prior to making dilutions.
- After usage remaining standard cannot be stored and has to be discarded.

## External standard dilution

- Label 6 tubes, one for each standard point: S2, S3, S4, S5, S6, S7.
- Then prepare 1:2 serial dilutions for the standard curve as follows: Pipette 150 µL of Calibrator Diluent into each tube.
- Pipette 150 µL of reconstituted (serves as highest standard S1 = 4 ng/mL) into the first tube, labeled S2, and mix (concentration of standard 2 = 2 ng/mL).
- Pipette 150 µL of this dilution into the second tube, labeled S3, and mix thoroughly before the next transfer.
- Repeat serial dilutions 4 more times thus creating the points of the standard curve (see Figure 7).

Calibrator Diluent serves as blank.

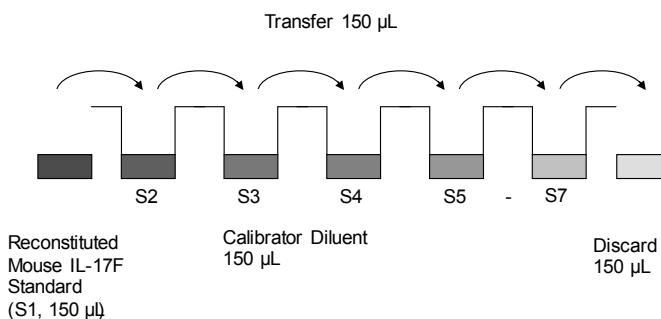

Fig. 7 External standard dilution

## Test protocol

- Determine the number of microwell strips required to test the desired number of samples plus appropriate number of wells needed for running blanks and standards. Each sample, standard, blank and optional control sample should be assayed in duplicate. Remove extra microwell strips from holder and store in foil bag with the desiccant provided at 2°-8°C sealed tightly.
- Wash the microwell strips twice with approximately 400 µL Wash Buffer per well with thorough aspiration of microwell contents between washes. Allow the Wash Buffer to sit in the wells for about 10 – 15 seconds before aspiration. Take care not to scratch the surface of the microwells.

After the last wash step, empty wells and tap microwell strips on absorbent pad or paper towel to remove excess Wash Buffer. Use the microwell strips immediately after washing. Alternatively microwell strips can be placed upside down on a wet absorbent paper for not longer than 15 minutes. Do not allow wells to dry.

- Add 50 µL of Sample Diluent to all wells.

- Add 50 µL of each prepared Standard dilution in duplicate to the corresponding standard well (see Table 1).

**Table 1** Example of the arrangement of blanks, standards and samples in the microwell strips:

	1	2	3	4
A	Standard 1 4000.0 pg/mL	Standard 1 4000.0 pg/mL	Sample 1	Sample 1
B	Standard 2 2000.0 pg/mL	Standard 2 2000.0 pg/mL	Sample 2	Sample 2
C	Standard 3 1000.0 pg/mL	Standard 3 1000.0 pg/mL	Sample 3	Sample 3
D	Standard 4 500.0 pg/mL	Standard 4 500.0 pg/mL	Sample 4	Sample 4
E	Standard 5 250.0 pg/mL	Standard 5 250.0 pg/mL	Sample 5	Sample 5
F	Standard 6 125.0 pg/mL	Standard 6 125.0 pg/mL	Sample 6	Sample 6
G	Standard 7 62.5 pg/mL	Standard 7 62.5 pg/mL	Sample 7	Sample 7
H	Blank	Blank	Sample 8	Sample 8

- Add 50 µL Calibrator Diluent to the blank wells.
- Add 50 µL of each sample in duplicate to the sample wells (see Table 1).
- Cover with an adhesive film and incubate at room temperature (18° to 25°C) for 2 hours on a microplate shaker.
- Prepare Biotin-Conjugate (see “Biotin-Conjugate” on page 3).
- Remove adhesive film and empty wells. Wash microwell strips 5 times according to point 2. of the test protocol. Proceed immediately to the next step.
- Add 100 µL of Biotin-Conjugate to all wells.
- Cover with an adhesive film and incubate at room temperature (18° to 25°C) for 1 hour on a microplate shaker.
- Prepare Streptavidin-HRP (refer to “Streptavidin-HRP” on page 3).
- Remove adhesive film and empty wells. Wash microwell strips 5 times according to point 2. of the test protocol. Proceed immediately to the next step.
- Add 100 µL of diluted Streptavidin-HRP to all wells, including the blank wells.
- Cover with an adhesive film and incubate at room temperature (18° to 25°C) for 1 hour on a microplate shaker.
- Remove adhesive film and empty wells. Wash microwell strips 5 times according to point 2. of the test protocol. Proceed immediately to the next step.
- Pipette 100 µL of TMB Substrate Solution to all wells.
- Incubate the microwell strips at room temperature (18° to 25°C) for about 30 minutes. Avoid direct exposure to intense light.

The color development on the plate should be monitored and the substrate reaction stopped (see next point of this protocol) before positive wells are no longer properly recordable. Determination of the ideal time period for color development has to be done individually for each assay.

It is recommended to add the stop solution when the highest standard has developed a dark blue color. Alternatively the color development can be monitored by the ELISA reader at 620 nm. The substrate reaction should be stopped as soon as Standard 1 has reached an OD of 0.9 – 0.95.

- Stop the enzyme reaction by quickly pipetting 100 µL of Stop Solution into each well. It is important that the Stop Solution is spread quickly and uniformly throughout the microwells to completely inactivate the enzyme. Results must be read immediately after the Stop Solution is added or within one hour if the microwell strips are stored at 2 - 8°C in the dark.
- Read absorbance of each microwell on a spectro-photometer using 450 nm as the primary wave length (optionally 620 nm as the reference wave length; 610 nm to 650 nm is acceptable). Blank the plate reader according to the manufacturer's instructions by using the blank wells. Determine the absorbance of both the samples and the standards.

**Note:** In case of incubation without shaking the obtained O.D. values may be lower than indicated below. Nevertheless the results are still valid.

### Calculation of results

- Calculate the average absorbance values for each set of duplicate standards and samples. Duplicates should be within 20 percent of the mean value.
- Create a standard curve by plotting the mean absorbance for each standard concentration on the ordinate against the mouse IL-17F concentration on the abscissa. Draw a best fit curve through the points of the graph (a 5-parameter curve fit is recommended).
- To determine the concentration of circulating mouse IL-17F for each sample, first find the mean absorbance value on the ordinate and extend a horizontal line to the standard curve. At the point of intersection, extend a vertical line to the abscissa and read the corresponding mouse IL-17F concentration.
- If instructions in this protocol have been followed, samples have not been diluted and the concentration read from the standard curve must not be multiplied by a dilution factor.
- Calculation of samples with a concentration exceeding standard 1 may result in incorrect, low mouse IL-17F levels. Such samples require further external predilution according to expected mouse IL-17F values with Calibrator Diluent in order to precisely quantitate the actual mouse IL-17F level.
- It is suggested that each testing facility establishes a control sample of known mouse IL-17F concentration and runs this additional control with each assay. If the values obtained are not within the expected range of the control, the assay results may be invalid.

- A representative standard curve is shown in Figure 8. This curve cannot be used to derive test results. Each laboratory must prepare a standard curve for each group of microwell strips assayed.

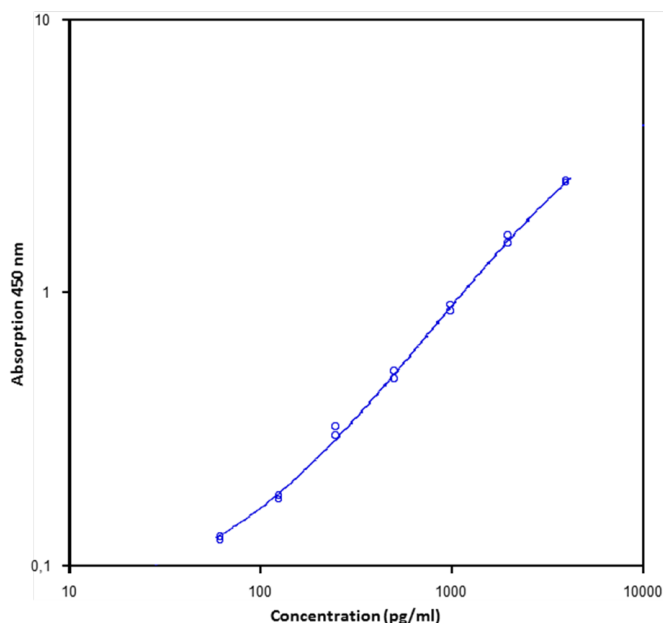

Fig. 8 Representative standard curve for Tween™ 20. Mouse IL-17F was diluted in serial 2-fold steps in Calibrator Diluent. Do not use this standard curve to derive test results. A standard curve must be run for each group of microwell strips assayed.

**Table 2** Typical data using the Tween™ 20.

Measuring wavelength: 450 nm

Reference wavelength: 620 nm

Standard	Mouse IL-17 F Concentration (pg/mL)	O.D. at 450 nm	Mean O.D. at 450 nm	C.V. (%)
1	4000.0	2.552 2.503	2.528	1.0
2	2000.0	1.605 1.504	1.554	3.3
3	1000.0	0.898 0.853	0.875	2.6
4	500.0	0.511 0.480	0.496	3.1
5	250.0	0.321 0.298	0.309	3.6
6	125.0	0.179 0.173	0.176	1.8
7	62.5	0.123 0.127	0.125	1.6
Blank	0	0.056 0.057	0.056	0.7

The OD values of the standard curve may vary according to the conditions of assay performance (e.g., operator, pipetting technique, washing technique, or temperature effects). Furthermore, shelf life of the kit may affect enzymatic activity and thus color intensity. Values measured are still valid.

## Limitations

- Since exact conditions may vary from assay to assay, a standard curve must be established for every run.
- Bacterial or fungal contamination of either screen samples or reagents or cross-contamination between reagents may cause erroneous results.

- Disposable pipette tips, flasks or glassware are preferred, reusable glassware must be washed and thoroughly rinsed of all detergents before use.
- Improper or insufficient washing at any stage of the procedure will result in either false positive or false negative results. Empty wells completely before dispensing fresh wash solution, fill with Wash Buffer as indicated for each wash cycle and do not allow wells to sit uncovered or dry for extended periods.

## Performance characteristics

### Sensitivity

The limit of detection of mouse IL-17F defined as the analyte concentration resulting in an absorbance significantly higher than that of the dilution medium (mean plus 2 standard deviations) was determined to be 10.0 pg/mL (mean of 6 independent assays).

### Reproducibility

#### Intra-assay

Reproducibility within the assay was evaluated in 3 independent experiments. Each assay was carried out with 6 replicates of 8 serum samples containing different concentrations of mouse IL-17F. 2 standard curves were run on each plate. Data below show the mean mouse IL-17F concentration and the coefficient of variation for each sample (see Table 3). The calculated overall intra-assay coefficient of variation was 4.2%.

**Table 3** The mean mouse IL-17F concentration and the coefficient of variation for each sample

Sample	Experiment	Mean Mouse IL-17F Concentration (pg/mL)	Coefficient of Variation (%)
1	1	5280.75	1.4
	2	5092.71	2.0
	3	5248.82	2.8
2	1	4052.25	2.9
	2	3780.59	4.2
	3	3884.60	3.3
3	1	1666.35	4.9
	2	1478.61	2.9
	3	1470.48	2.3
4	1	665.52	3.1
	2	599.79	4.8
	3	594.32	3.1
5	1	540.77	4.6
	2	491.81	2.9
	3	506.62	2.3
6	1	318.73	6.0
	2	305.60	5.7
	3	283.94	5.4
7	1	203.23	5.5
	2	198.62	7.5
	3	185.45	4.1
8	1	156.45	5.4
	2	144.83	9.3
	3	145.11	5.1

#### Inter-assay

Assay to assay reproducibility within one laboratory was evaluated in 3 independent experiments. Each assay was carried out with 6 replicates of 8 serum samples containing different concentrations of mouse IL-17F. 2 standard curves were run on each plate. Data below show the mean mouse IL-17F concentration and the coefficient of

variation calculated on 18 determinations of each sample (see Table 4). The calculated overall inter-assay coefficient of variation was 4.9%.

**Table 4** The mean mouse IL-17F concentration and the coefficient of variation of each sample

Sample	Mean Mouse IL-17F Concentration (pg/mL)	Coefficient of Variation (%)
1	5207.43	1.9
2	3905.81	3.5
3	1538.48	7.2
4	619.88	6.4
5	513.07	4.9
6	302.76	5.8
7	195.77	4.7
8	148.80	4.5

### Spike recovery

The spike recovery was evaluated by spiking 3 levels of mouse IL-17F into serum, plasma and cell culture supernatant. Recoveries were determined with 4 replicates each. The unspiked serum, plasma or cell culture supernatant was used as blank in these experiments.

Sample matrix	Spike high (%)	Spike medium (%)	Spike low (%)
Serum	105	100	107
Plasma (EDTA)	116	114	139
Cell culture supernatant	99	95	100

### Dilution parallelism

Serum, plasma and cell culture supernatant samples with different levels of mouse IL-17F were analyzed at serial 2 fold dilutions with 4 replicates each.

Sample matrix	Recovery of Exp. Val.	
	Range (%)	Mean (%)
Serum	102 - 133	112
Plasma (EDTA)	96 - 119	107
Cell culture supernatant	76 - 106	89

### Sample stability

#### Freeze-Thaw stability

Aliquots of serum samples (spiked) were stored at -20°C and thawed 3 times, and the mouse IL-17F levels determined. There was no significant loss of mouse IL-17F immunoreactivity detected by freezing and thawing.

#### Storage stability

Aliquots of serum samples (spiked) were stored at -20°C, 2-8°C, room temperature, and at 37°C, and the mouse IL-17F level determined after 24 hours. There was no significant loss of mouse IL-17F immunoreactivity detected during storage under above conditions.

### Specificity

The assay detects both natural and recombinant mouse IL-17F.

The cross reactivity and interference of circulating factors of the immune system was evaluated by spiking these proteins at physiologically relevant concentrations into a mouse IL-17F positive sample.

No crossreactivity to the IL-17AA homodimer is observed and less than 2.5% crossreactivity to IL-17AF heterodimer when spiked in excess (100 ng/mL).

### Expected values

Panels of 40 serum as well as EDTA plasma samples from randomly selected apparently healthy mice were tested for mouse IL-17F. There were no detectable mouse IL-17F levels found. Elevated mouse IL-17F levels depend on the type of immunological disorder.

## Reagent preparation summary

### Wash buffer (1x)

Add Wash Buffer Concentrate 20x (50 mL) to 950 mL distilled water.

Number of Strips	Wash Buffer Concentrate (mL)	Distilled Water (mL)
1 - 6	25	475
1 - 12	50	950

### Assay buffer (1x)

Add Assay Buffer Concentrate 20x (5 mL) to 95 mL distilled water.

Number of Strips	Assay Buffer Concentrate (mL)	Distilled Water (mL)
1 - 6	2.5	47.5
1 - 12	5.0	95.0

### Biotin-Conjugate

Make a 1:100 dilution of Biotin-Conjugate in Conjugate Diluent:

Number of Strips	Biotin-Conjugate (mL)	Conjugate Diluent (mL)
1 - 6	0.06	5.94
1 - 12	0.12	11.88

### Streptavidin-HRP

Make a 1:100 dilution of Streptavidin-HRP in Assay Buffer (1x):

Number of Strips	Streptavidin-HRP (mL)	Assay Buffer (1x) (mL)
1 - 6	0.06	5.94
1 - 12	0.12	11.88

### Mouse IL-17F standard

Reconstitute lyophilized mouse IL-17F standard with Calibrator Diluent. (Reconstitution volume is stated on the label of the standard vial.)

## Test protocol summary

- Determine the number of microwell strips required.
- Wash microwell strips twice with Wash Buffer.
- Add 50 µL Sample Diluent to all wells.
- Add 50 µL Calibrator Diluent to the blank wells.
- Add 50 µL standard in duplicate, to designated standard wells.
- Add 50 µL sample in duplicate, to designated sample wells.
- Cover microwell strips and incubate 2 hours at room temperature (18° to 25°C).
- Prepare Biotin-Conjugate.
- Empty and wash microwell strips 5 times with Wash Buffer.
- Add 100 µL Biotin-Conjugate to all wells.
- Cover microwell strips and incubate 1 hour at room temperature (18° to 25°C).
- Prepare Streptavidin-HRP.
- Empty and wash microwell strips 5 times with Wash Buffer.
- Add 100 µL diluted Streptavidin-HRP to all wells.
- Cover microwell strips and incubate 1 hour at room temperature (18° to 25°C).
- Empty and wash microwell strips 5 times with Wash Buffer.
- Add 100 µL of TMB Substrate Solution to all wells.
- Incubate the microwell strips for about 30 minutes at room temperature (18° to 25°C).
- Add 100 µL Stop Solution to all wells.
- Blank microwell reader and measure color intensity at 450 nm.

**Note:** If instructions in this protocol have been followed, samples have not been diluted and the concentration read from the standard curve must not be multiplied by a dilution factor.

## Customer and technical support

Visit [thermofisher.com/support](http://thermofisher.com/support) for the latest service and support information.

- Worldwide contact telephone numbers
- Product support information
  - Product FAQs
  - Software, patches, and updates
  - Training for many applications and instruments
- Order and web support
- Product documentation
  - User guides, manuals, and protocols

- Certificates of Analysis
- Safety Data Sheets (SDSs; also known as MSDSs)

**Note:** For SDSs for reagents and chemicals from other manufacturers, contact the manufacturer.

### Limited product warranty

Life Technologies Corporation and/or its affiliate(s) warrant their products as set forth in the Life Technologies' General Terms and Conditions of Sale at [www.thermofisher.com/us/en/home/global/terms-and-conditions.html](http://www.thermofisher.com/us/en/home/global/terms-and-conditions.html). If you have any questions, please contact Life Technologies at [www.thermofisher.com/support](http://www.thermofisher.com/support).



Bender MedSystems GmbH | Campus Vienna Biocenter 2 | 1030 Vienna, Austria

For descriptions of symbols on product labels or product documents, go to [thermofisher.com/symbols-definition](http://thermofisher.com/symbols-definition).

The information in this guide is subject to change without notice.

**DISCLAIMER:** TO THE EXTENT ALLOWED BY LAW, THERMO FISHER SCIENTIFIC INC. AND/OR ITS AFFILIATE(S) WILL NOT BE LIABLE FOR SPECIAL, INCIDENTAL, INDIRECT, PUNITIVE, MULTIPLE, OR CONSEQUENTIAL DAMAGES IN CONNECTION WITH OR ARISING FROM THIS DOCUMENT, INCLUDING YOUR USE OF IT.

**Important Licensing Information:** These products may be covered by one or more Limited Use Label Licenses. By use of these products, you accept the terms and conditions of all applicable Limited Use Label Licenses.

©2018 Thermo Fisher Scientific Inc. All rights reserved. All trademarks are the property of Thermo Fisher Scientific and its subsidiaries unless otherwise specified. All other trademarks are the property of their respective owners.