

# Thermo Scientific Forma 8600 Series

**-40C and -86C ULT Chest Freezer**

Operating and Maintenance Manual 7028700 Rev. 14

Visit us online to register your warranty  
[www.thermoscientific.com/labwarranty](http://www.thermoscientific.com/labwarranty)

**Thermo**  
SCIENTIFIC

**Important installer and user information:**

A redundant temperature sensing device has been included in this ULT freezer. This device is a type “T” thermocouple. For convenient access, the thermocouple (Figure 1-3) terminates in an interconnect jack (Figure 1-5) behind the base front cover. (May be located differently in chests. See Section 1). It is strongly recommended that this thermocouple be attached to a redundant 24 hour 7 day monitoring system with alarm capabilities. Connecting the sensor to a monitoring and alarm system separate from the freezer provides the utmost in product safety, should the integral system fail. ▲

**Packing List**

Part No.	Description	Qty
213F	Key	2
380520	Neoprene Cap	2
510016	1/4-20 x 5-1/2" Bolt	2
195763	Retaining Clip	1
370563	Remote Alarm Connector	1

**-86C Models Covered**

Number	Cu. ft.	Voltage/Hz
803CA	3	120/60
803CV	3	230/50
813CV	12.7	230/50
813CD	12.7	208-230/60
813CA	12.7	120/60
817CA	17	120/60
817CV	17	230/50
817CD	17	208-230/60
820CV	20	230/50
820CD	20	208-230/60
820CA	20	120/60

**-40C Models Covered**

Number	Cu. ft.	Voltage/ Hz
703CA	3	120/60
703CV	3	230/50
713CV	12.7	230/50
713CD	12.7	208-230/60
713CA	12.7	120/60
717CA	17	120/60
717CV	17	230/50
717CD	17	208-230/60
720CV	20	230/50
720CD	20	208-230/60
720CA	20	120/60

**MANUAL NUMBER 7028700**

14	ECNM-001188	01/19/21	Updated duration of Condenser Cleaning in page 5-2, F-Gas table in page 7-5, Assembly, Refrigeration schematic and Electrical schematic drawings.	TFI
13	ECNM-000779	04/29/2020	Updated Assembly, Electrical and Refrigeration schematic drawings.	TFI
12	ECNM-000625	01/17/20	Updated Intended and Unintended use, Safety precautions, Regulatory Compliance, Warning and Caution symbols. Removed statement related to foam blown in page 7.5. Updated Charge Quantity for -86°C in page 7-5.	



**Important** Read this operating manual. Failure to read, understand and follow the instructions in this manual may result in damage to the unit, injury to operating personnel, and poor equipment performance. ▲

**Caution** All internal adjustments and maintenance must be performed by qualified service personnel. ▲

Material in this manual is for information purposes only. The contents and the product it describes are subject to change without notice. Thermo Fisher Scientific makes no representations or warranties with respect to this manual. In no event shall Thermo be held liable for any damages, direct or incidental, arising out of or related to the use of this manual.

**Intended Use:** Thermo Scientific Forma 8600 Series  $-40^{\circ}\text{C}$  and  $-86^{\circ}\text{C}$  Ultra-Low Temperature (ULT) Chest Freezers described in this manual are intended to preserve samples by storing them at operating temperatures between  $-10^{\circ}\text{C}$  and  $-40^{\circ}\text{C}$  ( $-40^{\circ}\text{C}$  units) or  $-50^{\circ}\text{C}$  and  $-86^{\circ}\text{C}$  ( $-86^{\circ}\text{C}$  units).

The Freezers are intended for use:

- As a storage device in research use
- As a storage device in medical applications

**Non-Intended Use:** The Freezers are not intended to store samples that are re-introduced to the human body. The Freezers are not intended for use in classified hazardous locations and not to be used for the storage of flammable inventory.

© 2021 Thermo Fisher Scientific. All rights reserved.

# Safety precautions



This symbol when used alone indicates important operating instructions which reduce the risk of injury or poor performance of the unit.



**WARNING:** This symbol indicates potentially hazardous situations which, if not avoided, could result in serious injury or death.



**WARNING:** This symbol indicates situations where dangerous voltages exist and potential for electrical shock is present.



**CAUTION:** This symbol, in the context of a CAUTION, indicates a potentially hazardous situation which if not avoided could result in minor to moderate injury or damage to the equipment.



**CAUTION:** This indicates a situation which may result in property damage.



Before installing, using or maintaining this product, please be sure to read the manual and product warning labels carefully. Failure to follow these instructions may cause the product to malfunction, which could result in injury or damage.



This symbol indicates possible pinch points which may cause personal injury.



The snowflake symbol indicates low temperatures and risk of frost bite. Do not touch bare metal or samples with unprotected body parts.



This symbol indicates a need to use gloves during indicated procedures. If performing decontamination procedures, use chemically resistant gloves. Use insulated gloves for handling samples.

**Below are important safety precautions that apply to this product:**



Use this product only in the way described in the product literature and in this manual. Before using it, verify that this product is suitable for its intended use. If the equipment is used in a manner not specified by the manufacturer, the protection provided by the equipment may be impaired.



Do not modify system components, especially the controller. Use OEM exact replacement equipment or parts. Before use, confirm that the product has not been altered in any way.



**WARNING:** Your unit must be properly grounded in conformity with national and local electrical codes. Do not connect the unit to overloaded power sources.



**WARNING:** Disconnect the unit from all power sources before cleaning, troubleshooting, or performing other maintenance on the product or its controls.



**WARNING:** This unit is not for storage of flammable materials.



**WARNING:** Unauthorized repair of your freezer will invalidate your warranty. Contact Technical Service at 1-800-438-4851 for additional information.



**WARNING:** No equipment that uses an open flame should be placed inside the freezer. This will harm the unit, hamper functionality and compromise your safety.



**CAUTION:** Do not use any battery powered or externally-powered equipment in the freezer.



Equipment being maintained or serviced must be turned off and locked off to prevent possible injury.



## Do You Need Information or Assistance on Thermo Scientific Products?

If you do, please contact us 8:00 a.m. to 6:00 p.m. (Eastern Time) at:

1-740-373-4763

1-800-438-4851

1-877-213-8051

<http://www.thermofisher.com>

[service.led.marietta@thermofisher.com](mailto:service.led.marietta@thermofisher.com)

[www.unitylabservices.com](http://www.unitylabservices.com)

Direct

Toll Free, U.S. and Canada

FAX

Internet Worldwide Web Home Page

Tech Support Email Address

Certified Service Web Page

Our **Sales Support** staff can provide information on pricing and give you quotations. We can take your order and provide delivery information on major equipment items or make arrangements to have your local sales representative contact you. Our products are listed on the Internet and we can be contacted through our Internet home page.

Our **Service Support** staff can supply technical information about proper setup, operation or troubleshooting of your equipment. We can fill your needs for spare or replacement parts or provide you with on-site service. We can also provide you with a quotation on our Extended Warranty for your Thermo Scientific products.

Whatever Thermo Scientific products you need or use, we will be happy to discuss your applications. If you are experiencing technical problems, working together, we will help you locate the problem and, chances are, correct it yourself...over the telephone without a service call.

When more extensive service is necessary, we will assist you with direct factory trained technicians or a qualified service organization for on-the-spot repair. If your service need is covered by the warranty, we will arrange for the unit to be repaired at our expense and to your satisfaction.

Regardless of your needs, our professional telephone technicians are available to assist you Monday through Friday from 8:00 a.m. to 6:00 p.m. Eastern Time. Please contact us by telephone or fax. If you wish to write, our mailing address is:

Thermo Fisher Scientific (Asheville) LLC  
401 Millcreek Road, Box 649  
Marietta, OH 45750

International customers, please contact your local Thermo Scientific distributor.

# Table of Contents

<b>Section 1</b>	<b>Installation and Start-up</b> .....	<b>1-1</b>
	Control Panel Keys, Display, Indicators .....	1-5
	Install Freezer .....	1-7
	Displays .....	1-7
	RS-232 Communications .....	1-8
	Install Wall Bumpers .....	1-8
	Choose Location .....	1-8
	Remote Alarm Contacts and Analog Output .....	1-9
	Connect Unit to Electrical Power .....	1-10
	Attach Power Cord .....	1-10
	Freezer Start-Up .....	1-11
	Set Operating Temperature .....	1-11
	Set Low Temperature Alarm .....	1-12
	Set High Temperature Alarm .....	1-12
	Access Code .....	1-13
	Run Mode .....	1-13
<b>Section 2</b>	<b>Calibrate</b> .....	<b>2-1</b>
	Calibrate Mode .....	2-1
	Calibrate Control Probe .....	2-1
<b>Section 3</b>	<b>Configuration</b> .....	<b>3-1</b>
	Low Alarm Test .....	3-1
	High Alarm Test .....	3-1
	BUS Battery Test .....	3-2
	System Battery Test .....	3-2
	Set Access Code .....	3-3
	Clear High Stage Alarm .....	3-3
	Display Temperature .....	3-3
	Back Up System Type .....	3-4
	RS485 Address .....	3-4
	Reset Excursion .....	3-4
	Warm Excursion .....	3-4
	Cold Excursion .....	3-4
<b>Section 4</b>	<b>Alarms</b> .....	<b>4-1</b>
	Lost Communication .....	4-2
	Micro Board Failure Alarm .....	4-2
	Multiple Alarms .....	4-2
	High Stage System Failure Alarm .....	4-2

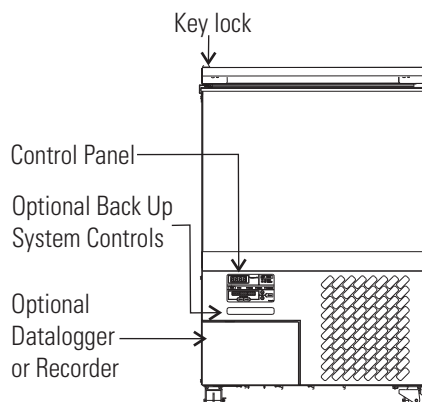


<b>Section 5</b>	<b>Maintenance</b> .....	<b>5-1</b>
	Clean Condenser .....	5-1
	Clean Air Filter .....	5-1
	Defrost Chamber .....	5-2
	Clean Lid Gasket .....	5-2
	Replace Battery(s) .....	5-2
	Check Battery(s) .....	5-4
	Prepare Unit for Storage .....	5-5
	PREVENTIVE MAINTENANCE .....	5-6
<b>Section 6</b>	<b>Factory Installed Options</b> .....	<b>6-1</b>
	Back Up System (BUS) .....	6-1
	Install Injection Assembly .....	6-1
	Install Temperature Probe .....	6-2
	Connect Probe/Solenoid Harness .....	6-4
	BUS Control Panel .....	6-4
	Configure Optional Back Up System (BUS) .....	6-7
	Set Optional BUS Set Point .....	6-7
	Test the BUS .....	6-7
	Disconnect Fitting Assembly, Transfer Hose .....	6-8
	Chart Recorder .....	6-8
	Install Chart Paper .....	6-8
	Change Program .....	6-9
	Calibrate Chart Recorder .....	6-9
<b>Section 7</b>	<b>Specifications</b> .....	<b>7-1</b>
<b>Section 8</b>	<b>Exploded Parts Drawings</b> .....	<b>8-1</b>
<b>Section 9</b>	<b>Refrigeration Schematics</b> .....	<b>9-1</b>
<b>Section 10</b>	<b>Electrical Schematics</b> .....	<b>10-1</b>
<b>Section 11</b>	<b>Warranty Information</b> .....	<b>11-1</b>
<b>Section 12</b>	<b>Regulatory Compliance</b> .....	<b>12-1</b>
	End of Life Care .....	12-3
	WEEE Compliance .....	12-4
<b>Appendix</b>	<b>Handling Liquid Nitrogen</b> .....	<b>A -1</b>
	Handling Liquid CO <sub>2</sub> .....	A-4
	First Aid .....	A-5

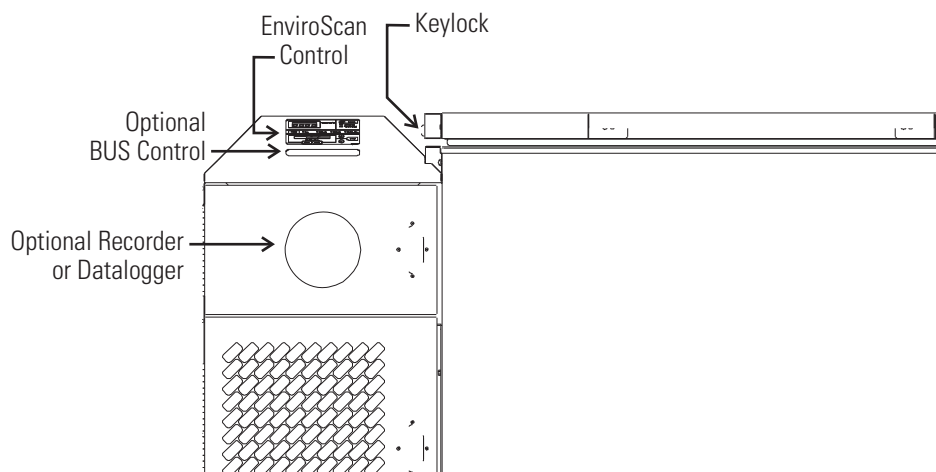
# Section 1 Installation and Start-up

Figures 1-1 and 1-2 show the front view of the freezer and indicate the following freezer components:

- Control Panel - Keypad, displays and indicators.
- BUS (Optional Back Up System) panel.
- Optional temperature recorder (7 day, one pen) or datalogger.
- Keylock - Keyed lid lock.



**Figure 1-1.** Front View 3 cu ft Models



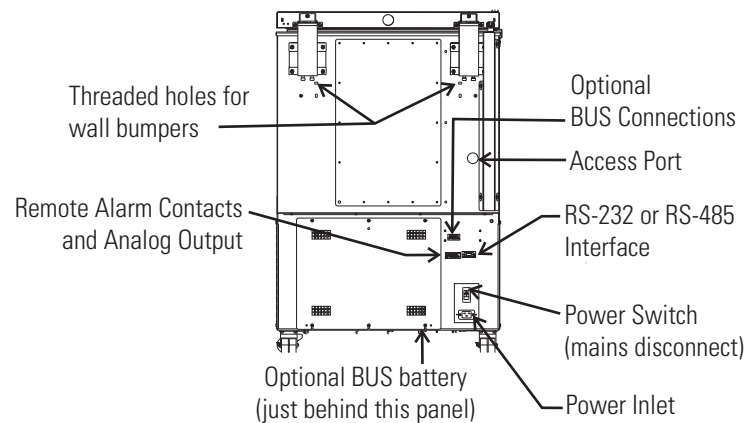
**Figure 1-2.** Front View Remaining Models

## Section 1

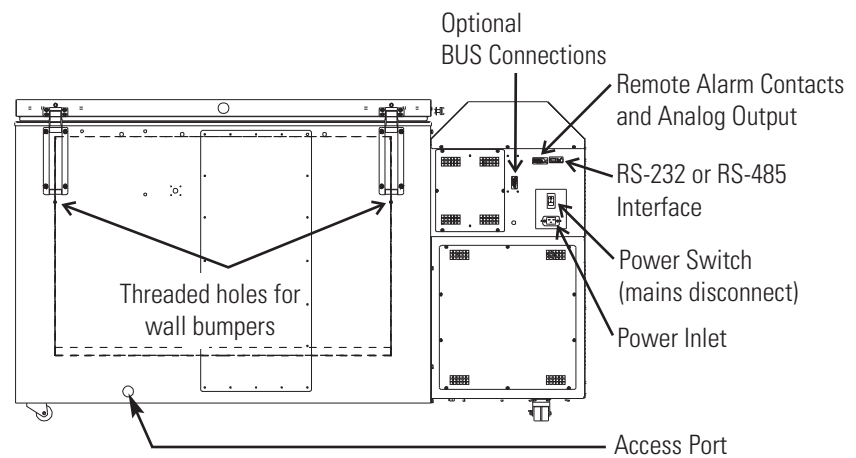
### Installation and Start-up

Figures 1-3 and 1-4 display the rear view of the freezer and indicate the following freezer components:

- Remote alarm contacts and selectable analog output connection: 0-1 V, 4-20 mA (default), 0-5 V.
- Power inlet for power cord connection.
- Optional BUS connections for probe and solenoid.
- RS-232 or RS-485 interface.
- Power Switch (mains disconnect).

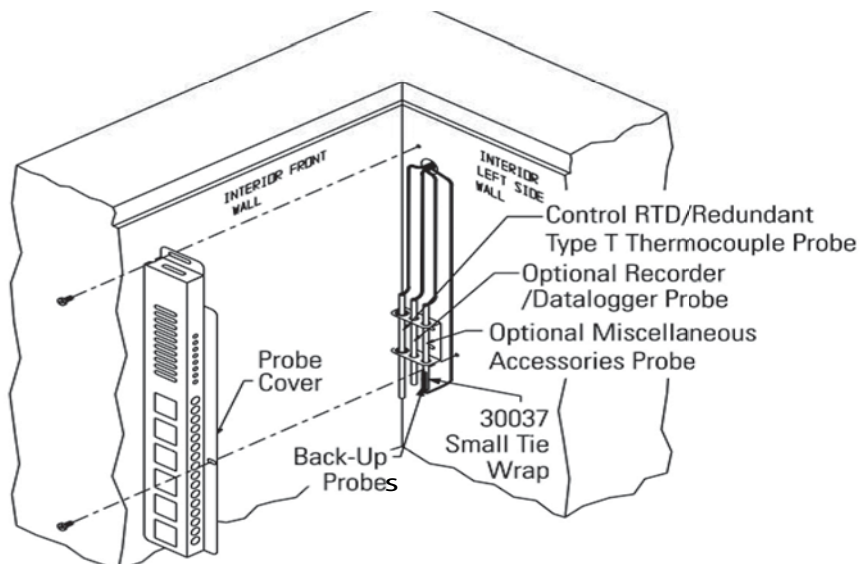


**Figure 1-3.** Rear View 3 cu ft Models



**Figure 1-4.** Rear View Remaining Models

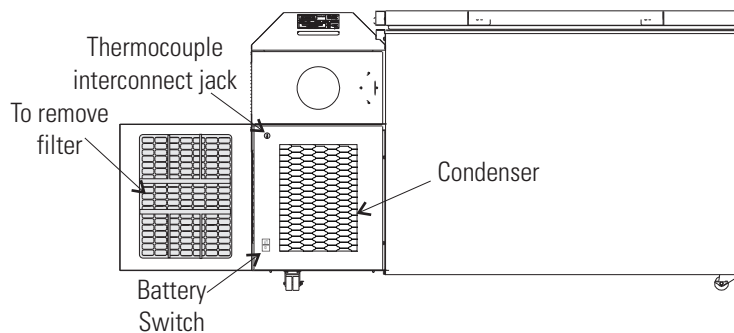
The probe cover houses the control, optional recorder, datalogger, 1535 alarm, or BUS probes.



**Figure 1-5.** Probe Cover

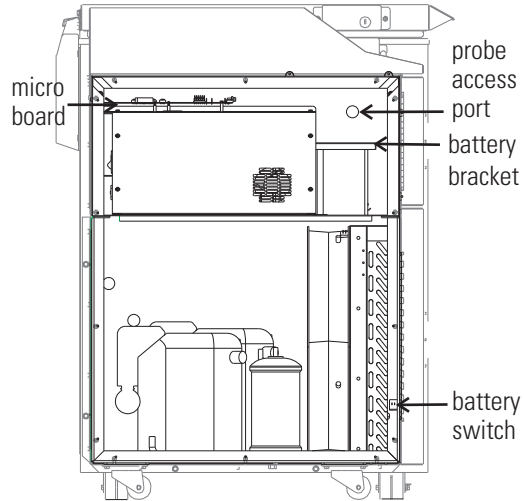
Figures 1-6, 1-7, and 1-8 indicate the following components:

- Freezer filter location
- Battery power switch (freezer and BUS)
- Thermocouple receptacle
- Battery mounting bracket
- Freezer and optional BUS battery

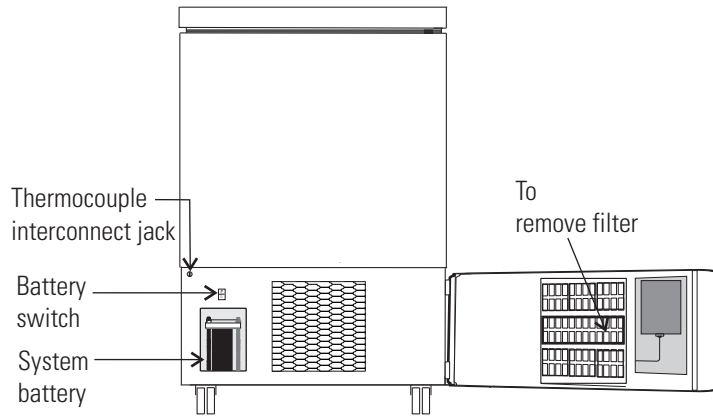


**Figure 1-6.** All Models Except 3 cu ft

**Section 1**  
Installation and Start-up



**Figure 1-7.** Freezer Left Side - Sidecar panel removed



**Figure 1-8.** 3 cu ft Models

## Control Panel Keys, Display, Indicators

Mode Select Switch - Used to select Run, Settings, Calibrate and System Configuration Modes.

Mode Select Indicators -

Run: Run Menu

Settings: Set Points Menu

Calibrate: Calibrate Menu

Configuration: Configuration Menu

Temperature Display - Displays temperature in degrees Celsius.

Alarm Indicator - Light pulses on/off during an alarm condition.

Silence - Mutes the audible alarm.

Low Battery - Indicates a low battery condition of the freezer battery.

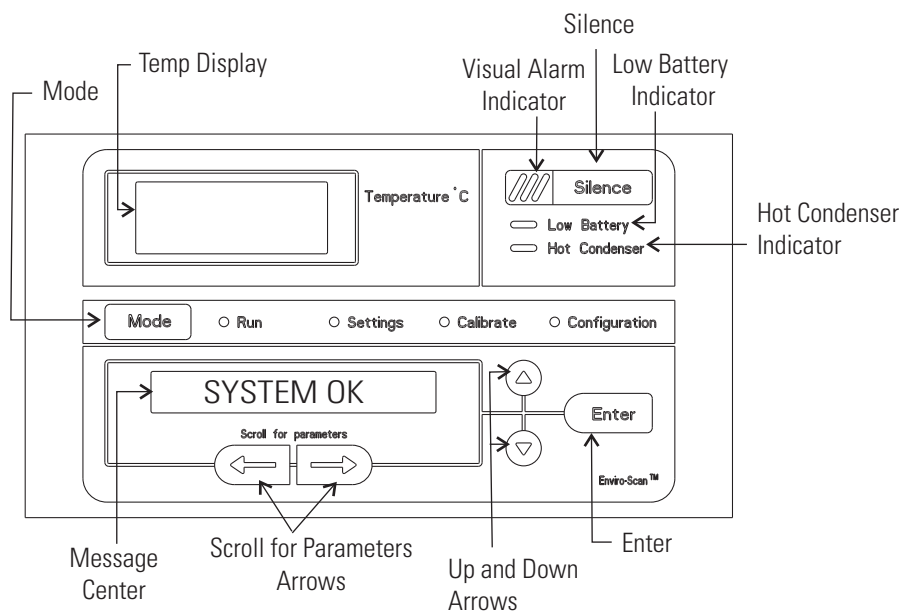
Hot Condenser - Indicates a hot condenser condition.

Message Center - Displays system status and alarms.

Scroll for Parameters Arrows - Moves through the choices of the selected mode.

Up and Down Arrows - Increases or decreases values, toggles between choices.

Enter - Stores the value into computer memory.



**Figure 1-9.** Control Panel Keys, Display and Indicators

**Section 1**

Installation and Start-up

# Panel Keys, Display, Indicators (cont.)

8600 Series freezers have four basic modes which allow freezer setup: Run, Settings, Calibrate and Configuration.

**Run** is the default mode which the freezer will normally be in during operation.

**Settings** is used to enter system set points for freezer operation.

**Calibrate** is used to calibrate various system parameters.

**Configuration** allows for custom setup of various options.

The chart below shows the selections under each of the modes.



Run	Settings	Calibrate	Configuration
Default Mode System Ok	Control Set Point	Control Probe	High Alarm Test
Line Voltage	High Alarm Set Point	Optional Sample Probe	Low Alarm Test
Compensated Voltage	Low Alarm Set Point		System Battery Test
* HSHX Temperature	Optional Back Up System Set Point		BUS Battery Test
			Display Temperature
			* Clear High Stage Alarm
			Set Access Code
			RS485 Address
			BUS type CO2 or LN2
			Cold Excursion
			Warm Excursion
			Reset Excursion

**Table 1-1.** Modes of Operation

\* -86C units only

## Panel Keys, Display, Indicators (cont.)

**Scroll for Parameters Arrows:** Steps the operator through the parameters of Settings, Calibrate and Configuration Modes. The right arrow goes to the next parameter, the left arrow returns to the previous parameter.

**Up Arrow:** Increases or toggles the parameter value that has been selected in the Settings, Calibrate, and Configuration Modes.

**Enter:** Must press Enter key to save to memory all changed values.

**Down Arrow:** Decreases or toggles the parameter values that have been selected in the Settings, Calibrate, and Configuration Modes.

**Silence Key:** Press to mute the audible alarm. See Section 4 for alarm ring-back times.

**Message Center:** Displays the system status (Mode) at all times. Displays SYSTEM OK during normal operation, or alarm messages if the system detects an alarm condition. See Section 4 - Alarms.

## Displays

There are two displays on the control panel. The temperature display shows the temperature in degrees Celsius. The message center displays the system status (Mode) at all times. The message SYSTEM OK displays during normal operation. Alarm messages are displayed if the system detects an alarm condition. See Section 4 - Alarms.

## Install Freezer

To remove the freezer from the pallet, use a 7/16" wrench to remove all the bolts securing the shipping bracket to the pallet.

**Note** If tipped more than 45°, allow the unit to set upright for 24 hours before start up. ▲

Refer to Instruction Sheet 7770800 to remove the cabinet from its shipping pallet.

The freezer can be easily pushed to the desired approved location, as described previously. When the freezer is in position, set the front caster brakes.



**Caution** Do not move the freezer with the product load inside. ▲



## Choose Location

Locate the freezer on a firm, level surface in an area with an ambient temperature between 18°C and 32°C. Provide ample room to reach the mains disconnect switch (power switch) located on the rear of the freezer.



**Caution** For proper ventilation and airflow, a minimum clearance of 5” at the rear and front and a clearance of 8” on the side of the freezer is required. Allow adequate space for lid opening. If ambient increases above 36°C, clearance at the rear of the cabinet must be increased to 8”. ▲

## Install Wall Bumpers

The parts bag, located inside the cabinet, contains the following parts.

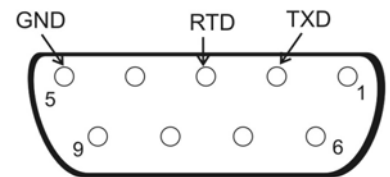
Quantity	Stock #	Description	Purpose
2	510016	1/4-20 x 5-1/2” Bolt	Wall Bumper
2	380520	Neoprene Cap	Cap Protector

Install the bolts into the pre-tapped holes on the back of the compressor section. Install a neoprene cap on each bolt. Refer to Figure 1-2 for the locations of the pre-tapped holes.

## RS-232 Communications

8600 Series freezers have a data communications interface. The factory default setting is RS-232.

The wiring identification for the interface is shown in Figure 1-10. One nine pin, sub "D" style connector is located on the back of the freezer. See Figure 1-2 for the location of the connector on the freezer.



**Figure 1-10.** RS-232 Interface

The freezer transmits temperature information every 60 minutes. A standard DB9 serial extension cable can be used to connect the freezer to a serial device. Some serial devices may require a null modem adapter.

Data format:

Baud .....1200  
 Data bits .....8 (7 bit ASCII with leading zero)  
 Start bits .....1  
 Stop bits .....2  
 Parity .....none

## RS-232 Communications (cont.)

The data transfer sequence is transmitted in the following format.

X refers to numerical temperature data.

(NUL) (-) XXX (SP) C (SP) (Error Message) (SP) (LF) (CR) (EOT) (SP)

In the event of a CNTRLFAIL, Er07, or the control probe is out of range error, the numerical temperature data (XXX) in the transmission would be replaced by T\_ERR.

If no alarm condition exists, spaces will be sent. A total of 20 characters will be sent.

SP - Space

LF - Line feed

CR - Carriage return

EOT - End of text (4)

NUL - Null character (00)

If an alarm condition does exist, "Error Message" in the protocol will be replaced by the following:

UNDERTEMP (Temperature above the low alarm setpoint)

OVERTEMP (Temperature below the high alarm setpoint)

PWRFAIL (AC power failure)

CNTRLFAIL (Control probe failure)

Er07 (Micro failure)

\* HSHX FAIL (Heat exchanger failure)

HOT COND (Hot condenser)

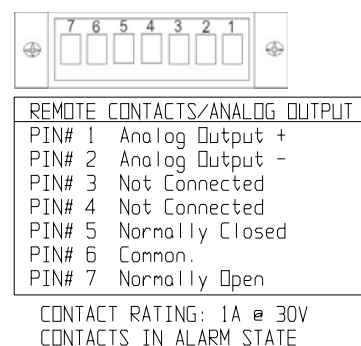
**Note** The RS-232 is not compatible with 1535 Monitor/Alarm System. ▲

\* -86C units only

## Remote Alarm Contacts and Analog Output

8600 Series freezers have remote alarm contacts and analog output. See Figures 1-3 and 1-4 for the location of the remote alarm contacts. The remote alarm connector is located in the parts bag provided with the manual. It must be installed if connecting the freezer to an alarm system. After installing the wiring from the alarm system to

the connector, install the connector to the freezer microboard and secure with the two screws provided. The remote alarm provides a NO (normally open) output, a NC (normally closed) output and COM (common). The contacts will trip on a power outage, high temperature alarm or low temperature alarm. They will also trip on high stage (-86C units only), control probe and microboard failures. Figure 1-11 shows the remote contacts in alarm state.



**Figure 1-11.** Remote Alarm Contacts

## Remote Alarm Contacts and Analog Output (cont.)

The analog output function allows the freezer to output signals representing the temperature of the freezer cabinet. The factory default setting is 4-20 mA. Refer to Table 1-2 for output specifications.

### IMPORTANT USER INFORMATION

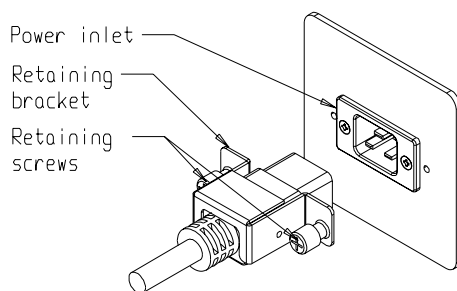
CAUTION! Stored product should be protected by a redundant 24 hour/day monitoring system with alarm capability. An interconnect jack and thermocouple are installed for centralized monitoring, should on-board system fail.

**Table 1-2.** Analog Output Specifications

	4-20 mA	0-1 V	0-5 V
Temperature	-100 to +50°C	-100 to +50°C	-100 to +50°C

## Attach Power Cord

Insert the power cord into the power inlet module. Place the retaining bracket (P/N 195763) over the connector. Tighten retaining screws to secure.



**Figure 1-12.** Power Cord Attachment

## Connect Unit to Electrical Power

**Note** See the serial tag on the side of the unit for electrical specifications or refer to the electrical schematics in this manual. ▲

The freezer should be operated on a dedicated, grounded service. Check the voltage rating on the serial tag of the unit and compare it with the outlet voltage. Then, with the power switch turned off, plug the line cord into the wall outlet.



**Warning:** Do not exceed the electrical rating printed on the data plate. ▲

First, turn on the freezer power switch. Then open the lower front door by grasping the bottom left corner. Locate the battery switch (Figure 1-4) and turn it to Standby mode (⏻). During initial freezer start-up, the system battery may require charging and the Low Battery message may appear in the message center.



**Caution:** Connect the equipment to the correct power source. Incorrect voltage can result in severe damage to the equipment. ▲



**Caution:** For personal safety and trouble-free operation, this unit must be properly grounded while in use. Failure to ground the equipment may cause personal injury or damage to the equipment. Always conform to the National Electrical Code and Local Codes. Do not connect the unit to overloaded power lines. ▲



**Caution:** Always connect the unit to a dedicated (separate circuit). Each unit is equipped with a service cord and plug designed to connect it to a power outlet which delivers the correct voltage. Supply voltage must be within  $\pm 10\%$  of the unit rated voltage. If cord becomes damaged, replace with a properly rated power supply cord. ▲



**Caution:** Never cut the grounding prong from the service cord plug. If the prong is removed, the warranty is invalidated. ▲

**Note** Ensure the battery switch is turned to Standby mode (⏻). The rechargeable batteries require 36 hours to charge at initial start-up. A “Low Battery” alarm may occur until the batteries are fully charged. Should a power failure occur during the initial start-up period, the electronics will have limited operation. ▲



**Caution:** In an emergency, the power cord is a disconnected device. ▲



**Caution:** Do not position the unit in a way that impedes access to the disconnecting device or circuit breaker in the back of the unit. ▲

## Freezer Start-Up

With the freezer properly installed and connected to power, system set points can be entered. The following set points can be entered in Settings mode: Control temperature, high temperature alarm set point, low temperature alarm set point, and (optional) BUS set point. Default settings are shown in the table below. See Chart 1-1 for more detail.

-86C Units		-40C Units	
Control Set Point	-80°C	Control Set Point	-40°C
High Temperature Alarm	-70°C	High Temperature Alarm	-30°C
Low temperature alarm	-90°C	Low temperature alarm	-50°C
Optional BUS Set Point	-60°C	Optional BUS Set Point	-30°C

**Note** If the set point is changed and the low temperature and high temperature alarms are set 10° from the set point, the alarm set points will be adjusted automatically to maintain a distance of at least 10° from set point. ▲

## Set Operating Temperature

The freezer has an operating temperature range of -50°C to -86°C (-86C units) or -10°C to -40°C (-40C units), depending on ambient temperature. The freezer is shipped from the factory with a temperature set point of -80°C (-86C units) or -40° (-40C units). To change the operating temperature set point:

1. Press the Mode key until the Settings indicator lights.
2. Press the right arrow until “SET PT = -XX” is displayed in the message center.
3. Press the up/down arrow key until the desired temperature set point is displayed.
4. Press Enter to save the set point.
5. Press the Mode key until the Run indicator lights for Run mode or press the right/left arrow keys to go to next/previous parameter.

If no control keys are pressed, the freezer will automatically return to RUN mode after 5 minutes.

## Set High Temperature Alarm

The high temperature alarm activates an audible/visual warning when the freezer chamber temp reaches or exceeds the high temp alarm set point.

To set the high temperature alarm set point:

1. Press the Mode key until the Set indicator lights.
2. Press right arrow until “HI ALM = -XX” displays in message center.
3. Press the up or down arrow key until the desired high temperature alarm set point is displayed.
4. Press Enter to save the setting.
5. Press the Mode key until the Run indicator lights or press the right or left arrow to go to the next or previous parameter.

If no control keys are pressed, the freezer will automatically return to RUN mode after 5 minutes.

**Note** The high alarm set point must be set at least 5°C from the control set point. ▲

**Note** At initial start-up, the high temperature alarm is disabled until the cabinet reaches set point or 12 hours elapse. ▲

## Set Low Temperature Alarm

The low temperature alarm activates an audible/visual warning when the freezer chamber temp reaches or decreases below low temp alarm set point.

To set the low temperature alarm set point:

1. Press the Mode key until the Settings indicator lights.
2. Press right arrow until “LO ALM = -XX” displays in message center.
3. Press the up or down arrow key until the desired low temperature alarm set point is displayed.
4. Press Enter to save the setting.
5. Press the Mode key until the Run indicator lights or press the right or left arrow to go to the next or previous parameter.

If no control keys are pressed, the freezer will automatically return to RUN mode after 5 minutes.

**Note** The low alarm set point must be set at least 5°C from the control set point. ▲

## Access Code

An access code can be set to prevent unauthorized change of settings in Calibrate, Configuration and Settings mode. (An access code of 000 is required to make changes). If the access code is not at the default 000, you can not leave RUN mode without entering a code. See Section 3, Configuration for instructions on modifying the access code.

## Run Mode

Run mode is the default mode for the freezer. The run mode displays the cabinet temperature on the temperature display and ‘SYSTEM OK’ on the message center under normal operating conditions. In addition, the Run mode allows display of the following information:

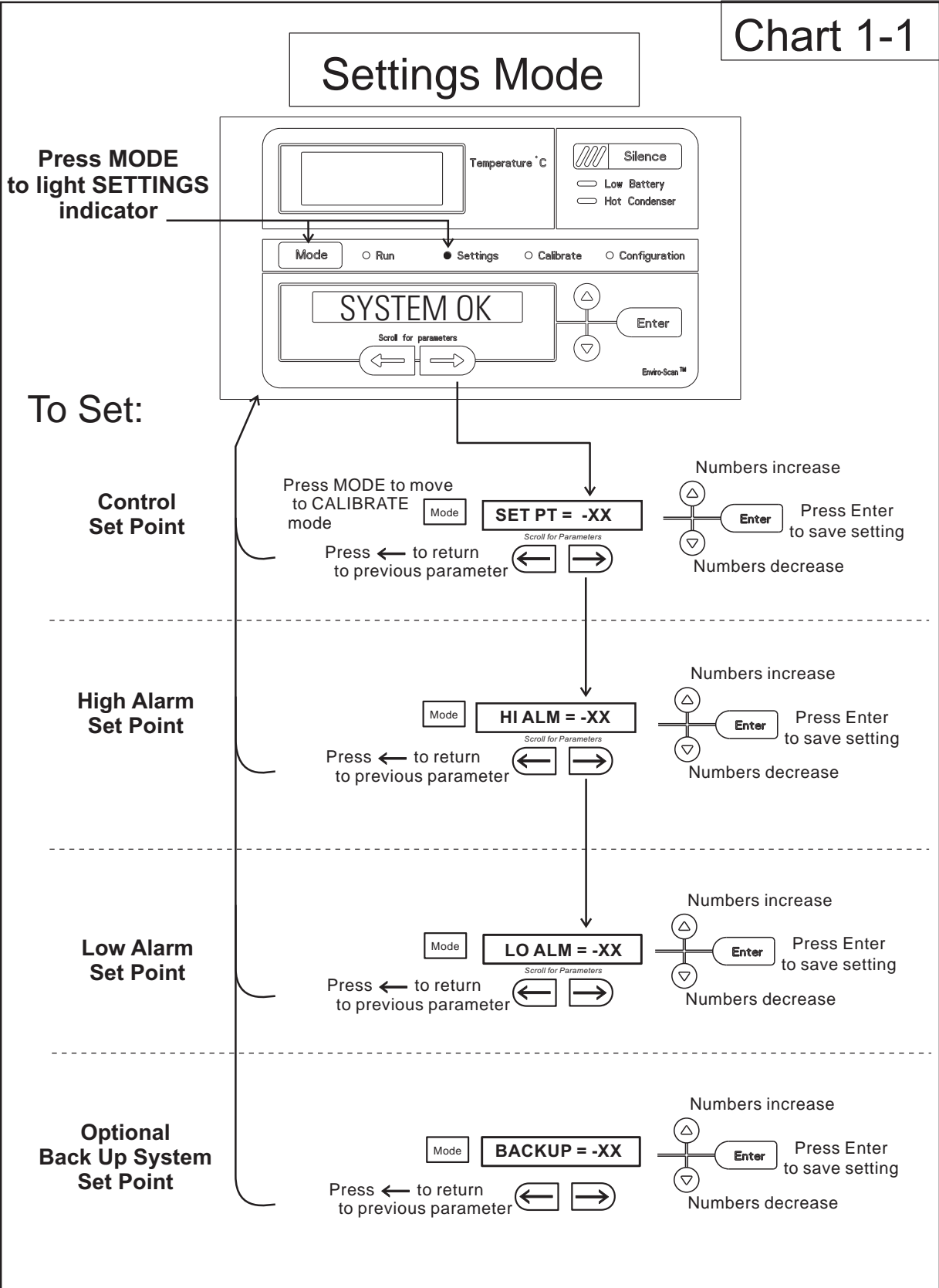
LINE VOLTAGE

COMPENSATED VOLTAGE

\* HSHX TEMPERATURE (heat exchanger temperature); -86C units only

This information is scrolled individually by pressing the right arrow key. In each case, the message center returns to SYSTEM OK in 10 seconds if no keys are pressed.

Chart 1-1



## Section 2 Calibrate

### Calibrate Mode

Once the freezer has stabilized, the control probe may need to be calibrated. Calibration frequency is dependent on use, ambient conditions and accuracy required. A good laboratory practice would require at least an annual calibration check. On new installations, all parameters should be checked after the stabilization period.

**Note** Before making any calibration or adjustments to the unit, it is imperative that all reference instruments be properly calibrated. ▲

### Calibrate Control Probe

Plug a type T thermocouple reader into the receptacle located inside the lower door (see Figures 1-4 and 1-6). Compare the control temperature set point to the temperature of the measuring device. See Chart 2-1 at the end of this section for more detail.

1. Press the Mode key until the Calibrate indicator lights.
2. Press the right arrow until “CONT T = -XX.X” appears in the message center.
3. Press up/down arrow to match the display to calibrated instrument.
4. Press Enter to store calibration.
5. Press the Mode key to return to Run or the right/left arrow to go to next/previous parameter.

### Temperature Stabilization Periods

Startup - Allow 12 hours for the temperature in the cabinet to stabilize before proceeding.

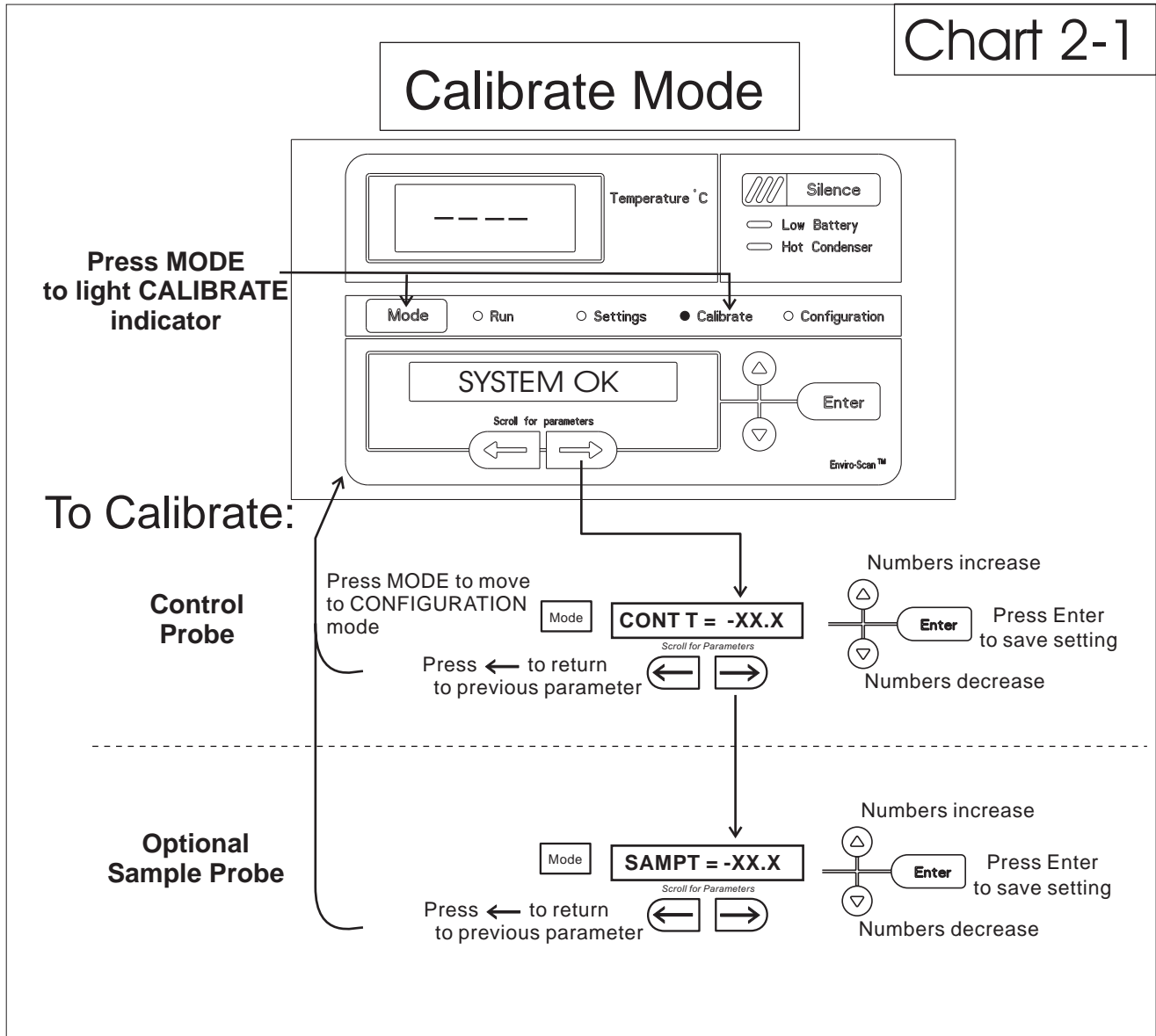
Already Operating - Allow at least 2 hours after the display reaches set point for temperature to stabilize before proceeding.

Note During calibration, the temperature display will not be available.

If no keys are pressed for approximately five minutes while in calibration mode, the system will reset to Run mode.



Chart 2-1



## Section 3 Configuration

Configuration Mode is used for testing and custom setup of the freezer. The configuration functions listed and described below may not be necessary in all applications, but are available if needed. See Chart 3-1 for more detail.

### High Alarm Test

The high alarm test is used to verify that the high alarm will activate, should the freezer temperature equal or exceed the high alarm set point.

1. Press the Mode key until the Configuration indicator lights.
2. Press the right arrow until HI ALRM TEST is displayed in the message center.
3. Press Enter to initiate the test.

The temperature on the display will begin to increase until the high alarm set point has been reached. The audible alarm will sound and the alarm indicator will flash. Press the Silence key to mute the alarm.

### Low Alarm Test

The low alarm test is used to verify the that low alarm will activate, should the freezer temperature equal or become less than the low alarm set point.

1. Press the Mode key until the Configuration indicator lights.
2. Press the right arrow until LO ALRM TEST is displayed in the message center.
3. Press Enter to initiate the test.

The temperature on the display will begin to decrease until the low alarm set point has been reached. The audible alarm will sound and the alarm indicator will flash. Press the Silence key to mute the alarm.

## **System Battery Test**

To test the charge of the freezer battery:

1. Press the Mode key until the Configuration indicator lights.
2. Press the right arrow until SYS BAT TEST is displayed in the message center.
3. Press Enter to initiate the test.

TESTING BATT will display during the testing period. Upon completion of the test the message center will display BATT GOOD or BATT FAIL. When a test is failed, the audible alarm will sound, the alarm indicator and the Low Battery indicator will light. Press the Silence key and the alarm indicator will go off. The Low Battery light will stay on until a future battery test is performed and passed.

## **BUS Battery Test**

To test the charge of the BUS battery:

1. Press the Mode key until the Configuration indicator lights.
2. Press the right arrow until BUS BAT TEST is displayed in the message center.
3. Press Enter to initiate the test.

TESTING BATT will display during the testing period. Upon completion of the test the message center will display BBAT GOOD or BBAT FAIL. If this test fails, the audible alarm will sound, the alarm indicator and the Low Battery indicator will light. Press the Silence key. The audible alarm and alarm indicator will go off. The Low Battery light will stay on. If the test fails, it is recommended to replace the BUS battery.

## Display Temperature

This function, only available on freezers with the optional sample probe, allows the user to select which temperature is displayed in the temperature display window. The options are CONTROL or SAMPLE.

1. Press the Mode key until the Configuration indicator lights.
2. Press the right arrow until DISP CONTROL or DISP SAMPLE is displayed in the message center.
3. Press up/down arrow to toggle between the two display selections.
4. Press Enter to save.

If control probe is selected, the temperature display will be on continuously. If sample probe is selected, the temperature display will be preceded with a letter 'S'.

## Clear High Stage Alarm (-86C units only)

Should a high stage alarm have occurred, it may become necessary to clear the alarm condition after the condition has been corrected.

1. Press the Mode key until the Configuration indicator lights.
2. Press the right arrow until CLR HS ALARM is displayed in the message center.
3. Press Enter to clear the alarm.

## Set Access Code

To set the Access Code:

1. Press the Mode key until the Configuration indicator lights.
2. Press the right arrow until "SET ACC CODE" is displayed in the message center.
3. Press Enter.
4. The message center will display ACC CODE = 000. Press the up or down arrow key until the desired access code is displayed (000 - 999). Press the left or right arrow key to select digit 1, 2, 3.

**Note** The left and right arrow keys are used to move from the first through the third digits within the access code. ▲

5. Press Enter to save the setting
6. Press the Mode key until the Run indicator lights. A 3-digit Access Code can be entered to avoid unauthorized personnel from changing the set points, calibration, or configuration. A setting of 000 will bypass the access code. The factory setting is 000.

## RS485 Address

If the freezer is configured for RS-485 communications, it will need to have a unique identification address. This address is set through the Configuration mode.

1. Press the Mode key until the Configuration indicator lights.
2. Press the right arrow until RS485ADDR is displayed in the message center.
3. Press Enter. The message center will display 485 ADDR XX.
4. Press up/down arrow to select the appropriate address for the freezer (1 - 24).
5. Press Enter to save.

## Back Up System Type

This function, which is only available on freezers with the optional back up system (BUS), allows the user to select which type of gas is injected into the freezer chamber. The options are CO<sub>2</sub> and LN<sub>2</sub>.

1. Press the Mode key until the Configuration indicator lights.
2. Press the right arrow until BUS TYPE CO<sub>2</sub> or BUS TYPE LN<sub>2</sub> is displayed in the message center.
3. Press up/down arrow to toggle between the two display selections.
4. Press Enter to save.

## Cold Excursion

This function displays the coldest temperature recorded by the control probe.

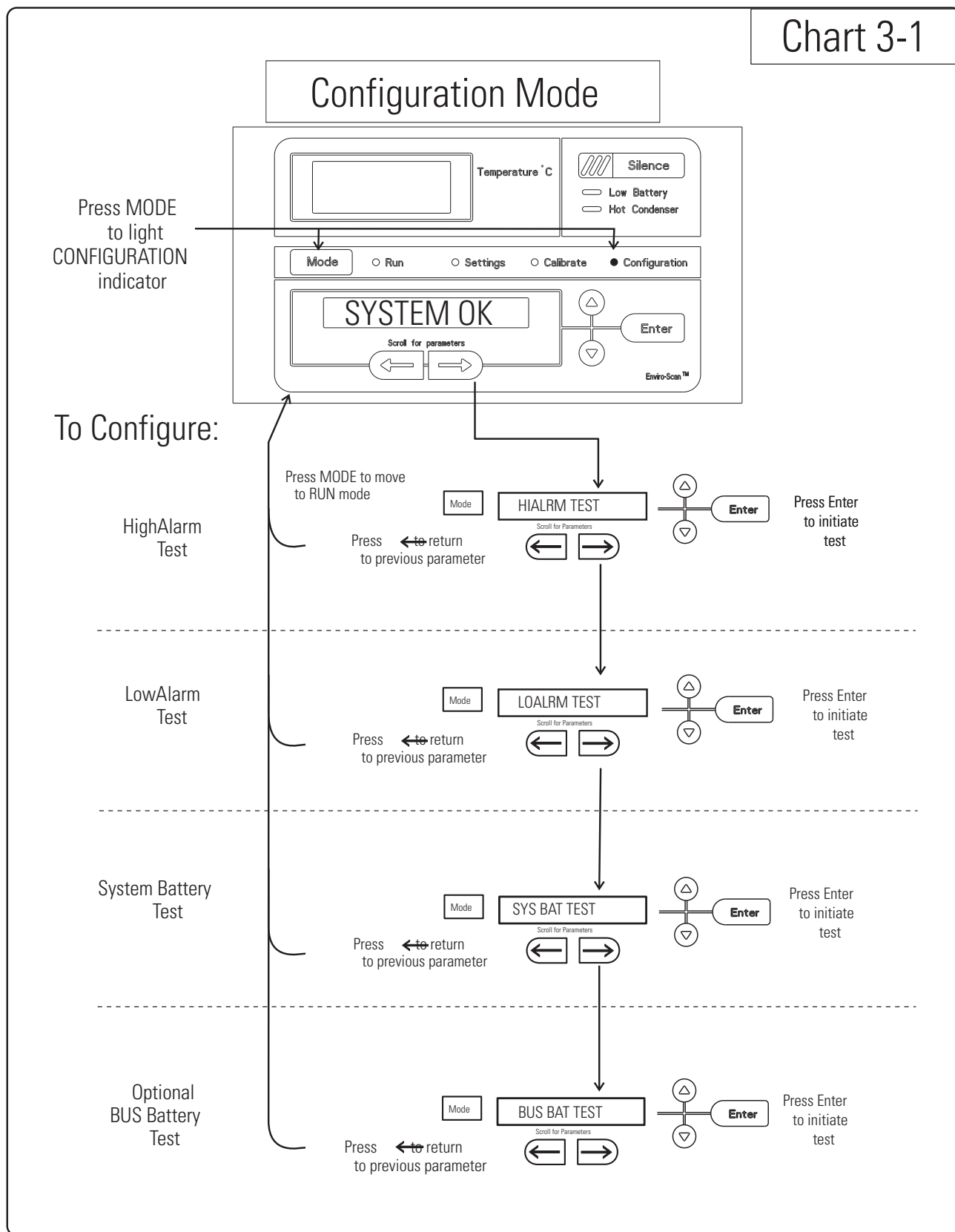
## Warm Excursion

This function displays the warmest temperature recorded by the control probe.

## Reset Excursion

This function resets the cold and warm excursions.

Chart 3-1

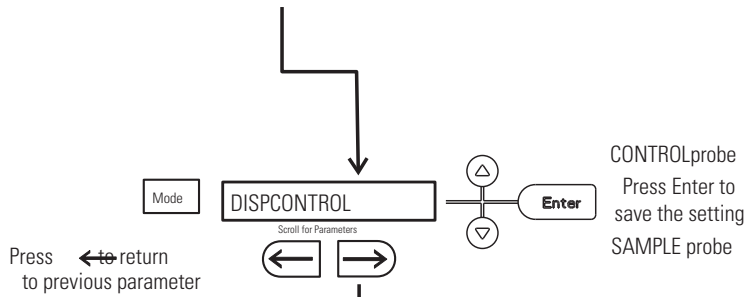


# Configuration Mode, Chart 3-1, Page 2 of 3

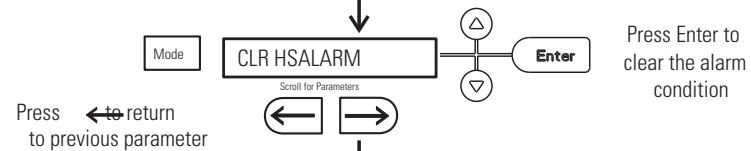
refer to previous page

To Configure:

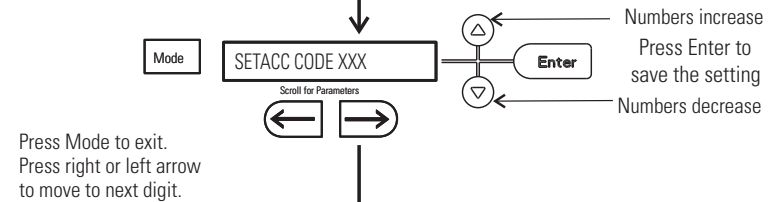
Display Temperature



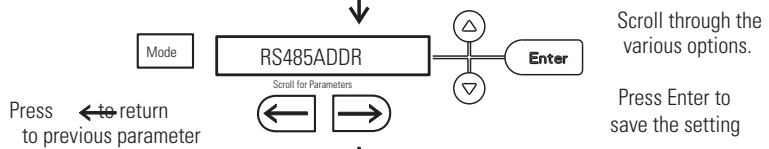
Clear High Stage Alarm



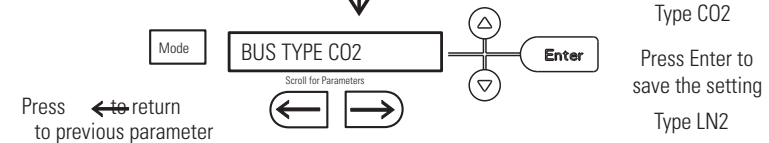
Access Code



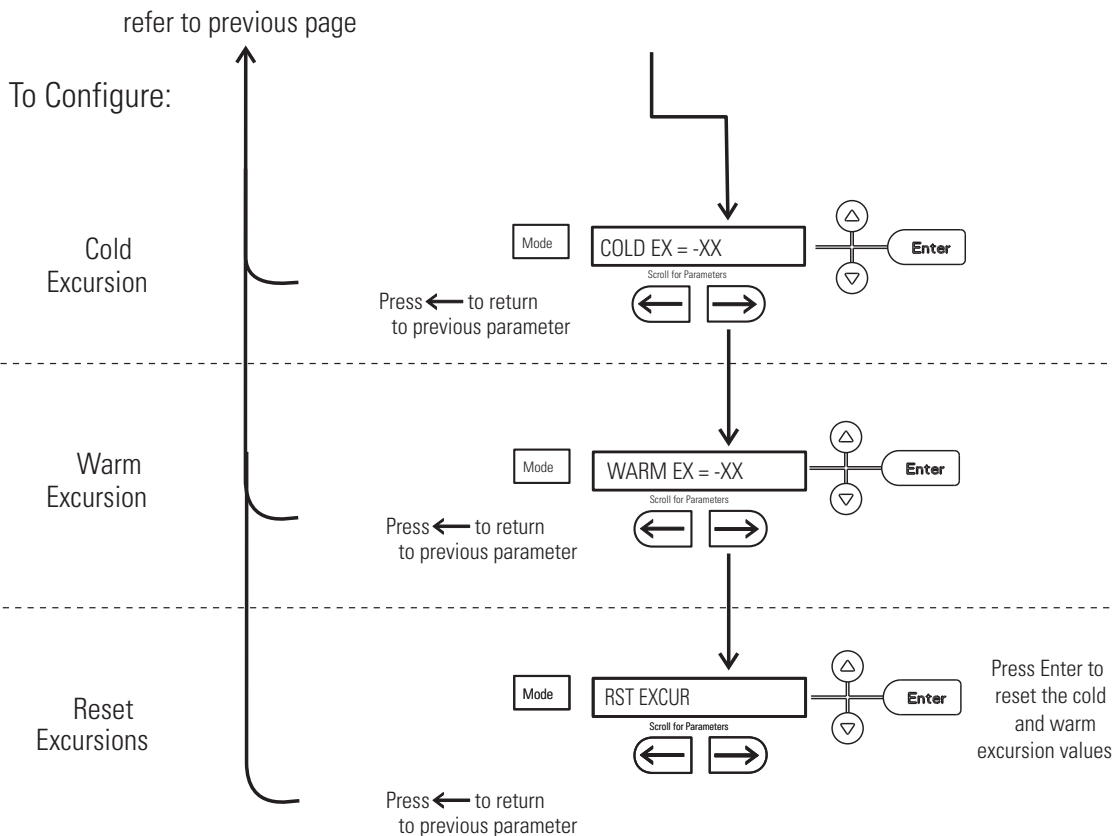
RS-485 Address



Optional Back Up System Type



# Configuration Mode, Chart 3-1, Page 3 of 3





**Section 3**  
Configuration

## Section 4 Alarms

The 8600 Series freezer alarm system is shown below. When an alarm is active, a message appears in the LED message center. Press the Silence key to mute the audible alarm for the ringback period. The visual alarm continues until the freezer returns to a normal condition. The alarms are momentary alarms only. If an alarm condition occurs and then returns to normal, the freezer automatically clears the alarm condition and the message center.

**Table 4-1.** Alarms

Description	Message	Delay	Ringback	Relay
No alarm condition exists	SYSTEM OK	----	----	----
Power Failure	POWER FAIL	1 min.	15 min.	Yes
High Temperature Alarm	TEMP IS HIGH	1 min.	15 min.	Yes
Low Temperature Alarm	TEMP IS LOW	1 min.	15 min.	Yes
Door Ajar	DOOR IS OPEN	1 min.	15 min.	No
Low Battery*	LOW BATTERY	1 min.	8 hours	No
Low BUS Battery (optional)	LOW BUS BATT	1 min.	15 min.	No
Control Probe Failure	CNT PRB FLT	1 min.	15 min.	Yes
Heat Exchanger Probe Failure **	HSHX PRB FLT	1 min.	15 min.	No
Condenser Probe	COND PRB FLT	1 min.	15 min.	No
Sample Probe Failure (optional)	SMPL PRB FLT	1 min.	15 min.	No
High Stage System Failure **	HS SYST FAIL	1 min.	15 min.	YES
Condenser Hot Condition	HOT CONDENSER	1 min.	none	No
Wrong Power	WRONG POWER	0 min.	none	YES
Micro Board Failure	MICRO FAIL	0 min.	15 min.	YES

*All alarm delays and ringback times are +30 seconds.*

*\*The automatic battery test runs immediately on power-up, then every 8 hours thereafter.*

*\*\* -86C units only*

### **High Stage System Failure Alarm (-86C units only)**

This condition is created when the high stage compressor and fans run for 30 minutes and are not capable of cooling the interstage heat exchanger to the proper temperature. Under this condition, the high stage compressor and fans will turn off after 30 minutes and an audible and visual alarm will occur along with the "HS SYST FAIL" message in the LED message center.

### **Multiple Alarms**

When multiple alarm conditions occur, active messages are displayed in the message center one at a time, updating at 5 second intervals. Pressing Silence during multiple alarms causes all active alarms to be silenced and to ring back in 15 minutes.

### **Micro Board Failure Alarm**

An internal communication failure has occurred with the micro board. During this alarm, the compressor(s) attempt to run continuously. However, with this type of failure, freezer operation becomes undependable.

### **Lost Communication**

Communication between the micro board and the display board has been lost. Under this condition, the visual alarm flashes along with dashes in the temperature display (----). Contact Technical Services.

Error	High End Message	Notes
Er00	"INV. MODEL"	<p><b>Name:</b> Improper model selected.</p> <p><b>Description:</b> Indicates that DIP SW3 has not selected a proper model or can't be accessed properly.</p> <p><b>Response:</b> Display shows "Er00" and will not start-up until a proper model is selected. Contact Technical Services.</p>
ErA1	" NO FREQUENCY"	This error condition will prevent peripherals (fans, compressors, etc.) from powering up with the incorrect voltage.
ErC1	"FREQ <50 Hz"	<p><b>Name:</b> Voltage/Frequency failure</p> <p><b>Description:</b> Indicates the measured RMS line voltage did not agree with the logic level sensed by the micros provided by the installed high voltage PCB; or the measured RMS voltage is not within a tolerable range (&lt;180 VAC &lt; 270 for 230 VAC unit / &lt;85 VAC &lt; 160 for 115 VAC unit); or the frequency measured over 10 cycles was not within a tolerable range (55 Hz &lt; Freq &lt; 70 Hz for 60 Hz units / 40 Hz &lt; Freq &lt; 55 Hz for 50 Hz units)</p>
ErD1	"FREQ >60 Hz"	
ErE1	"VAC < 180 V"	<p><b>Response:</b> This condition is checked at power on reset and if it is active the unit will NOT power up. The unit will indefinitely display "Er_1" in the display and continue to monitor the frequency and voltage. Furthermore, the audible alarm will sound. Other startup error messages may be displayed prior to this message; however, the system will stop the startup sequence for this condition.</p>
ErF1	"VAC > 260 V"	<p>ErA1 .. No pulses (zero crossings) detected to determine frequency (50 / 60 Hz)</p> <p>ErC1 .. Frequency detected is below 50 Hz</p> <p>ErD1 .. Frequency detected is above 60 Hz (Possible noise spikes on supply voltage)</p>
Erg1	"VAC < 85 V"	<p>ErE1 .. Unit is 230 V and the voltage detected is below the low limit (180 VRMS)</p> <p>ErF1 .. Unit is 230 V and the voltage detected is above the high limit (260 VRMS)</p> <p>Erg1 .. Unit is 115 V and the voltage detected is below the low limit (85 VRMS)</p>
ErH1	"VAC > 160 V"	<p>ErH1 .. Unit is 115 V and the voltage detected is above the high limit (160 VRMS)</p>

**Section 4**

Alarms

Error (cont.)	High End Message	Notes
Er02	"CNT PRB FLT"	<p><b>Name:</b> Control (Cabinet) Sensor Failure</p> <p><b>Description:</b> This condition indicates that the control sensor has failed to produce a valid reading for <math>\geq 12</math> consecutive reads (~60 seconds).</p> <p><b>Response:</b> The unit will stage both compressors on (if necessary) and the unit will attempt to head to bottom out. If the sensor recovers, the system will begin to operate normally and respond to the temperature feedback. The remote alarm contacts will become active regardless of the key position for this mode of failure. 'Er02' will be added to the main display queue and the last valid cabinet temperature value will not be displayed</p>
Er03	"HSHX PRB FLT" -86C units only	<p><b>Name:</b> Heat Exchange Sensor Failure</p> <p><b>Description:</b> This condition indicates that the heat exchange sensor has failed to produce a valid reading for <math>\geq 12</math> consecutive reads (~60 seconds).</p> <p><b>Response:</b> The display will show "Er03" only when the button sequence to read the heat exchange sensor is depressed.</p>
Er05	N/A	<p><b>Name:</b> Display Firmware Integrity Failure</p> <p><b>Description:</b> The display firmware has failed to pass its CRC CCITT checksum integrity test.</p> <p><b>Response:</b> The display performs this check at startup and the display board will fail to startup with out any error indication if it does not pass this at power on.</p>
Er06	N/A	<p><b>Name:</b> Micro Firmware Integrity Failure</p> <p><b>Description:</b> The micro firmware has failed to pass its CRC CCITT checksum integrity test.</p> <p><b>Response:</b> This is checked at power on reset and the "Er06" will be displayed for ~10 seconds at startup if this condition exists.</p>
Er07	"MICRO FAIL"	<p><b>Name:</b> Micro Fail - CS5521 SPI Failure / UISR Failure</p> <p><b>Description:</b> This condition indicates a micro board failure due to either the SPI bus is unable to communicate with the ADC device or a UISR event caused the microcontroller to be in an unstable state.</p> <p><b>Response:</b> The unit will try to recover from this fault three times by a hardware reset of the micro board. In the event that the system couldn't rectify the issue, the following sequence of events will occur:</p> <ol style="list-style-type: none"> <li>1. Remote alarm contacts will become active.</li> <li>2. Buzzer will annunciate audibly and will have a ringback of 15 minutes.</li> <li>3. "Seven segment" display will show "Er07".</li> <li>4. The -86C system will have 10 minute staging between the high stage compressor and the low stage compressor activation (-40C units will activate the compressor).</li> <li>5. The system will go to bottom out temperatures.</li> </ol>

Error (cont.)	High End Message	Notes
Er09	N/A	<p><b>Name:</b> Stuck Button</p> <p><b>Description:</b> This condition indicates that the display board has a stuck button.</p> <p><b>Response:</b> The Er09 will show on the display periodically.</p>
Er11	"COND PRB FLT"	<p><b>Name:</b> Condenser Probe Sensor Failure</p> <p><b>Description:</b> This condition indicates that the condenser probe sensor has failed to produce a valid reading for <math>\geq 12</math> consecutive reads (~60 seconds).</p> <p><b>Response:</b> The display shows "Er11".</p>
N/A	"SMPL PRB FLT"	<p><b>Name:</b> Sample Probe Sensor Failure</p> <p><b>Description:</b> This condition indicates that the sample probe sensor has failed to produce a valid reading for <math>\geq 12</math> consecutive reads (~60 seconds).</p> <p><b>Response:</b> The message center shows "SMPL PRB FLT".</p>
dErr	N/A	<p><b>This is a general display error in which the value being displayed can not be represented within the characters provided.</b></p>
(four dashes) ---- in display	N/A	<p><b>Name:</b> Lost Communication</p> <p><b>Description:</b> Communication between the micro board and the display board has been lost. Under this condition, the visual alarm flashes along with dashes in the temperature display (----). Contact Technical Services.</p>

**Section 4**  
Alarms

## Section 5 Maintenance



**Warning** Disconnect equipment from main power before attempting any maintenance to equipment or its controls unless stated otherwise. ▲

Wipe down the freezer exterior using soap and water and a general use laboratory disinfectant. Rinse thoroughly with clean water and dry with a soft cloth.



**Caution** Avoid the excessive use of water around the control area due to the risk of electrical shock. Damage to the controls may also result. ▲

### Clean Air Filter

The air filter should be cleaned a minimum of four times per year.

1. Open the lower panel door by grasping the handle.
2. Locate the grille on the door. See Figures 1-6 and 1-8. Grasp the middle of the grille material and gently pull out to remove.
3. Wash the filter material using water and a mild detergent.
4. Dry by pressing between two towels.
5. Install the filter back into the grille and close the door.

Depending upon environmental conditions, the filter may need to be cleaned or replaced more frequently. If the filter becomes torn or excessively dirty, a replacement can be purchased from Thermo. Order part number 398216 for 3 cu. ft. units, or 398217 for 13, 17, and 20 cu. ft. units.

### Clean Condenser

The condenser should be cleaned a minimum of once per year.

1. Open the lower panel door by grasping the handle. See Figures 1-6 and 1-8.
2. Using a vacuum cleaner, exercising care to not damage the condenser fins, clean the condenser.



## Clean Condenser (cont.)

**Caution** Condensers should be cleaned at least every year; more often if the laboratory area is dusty. In heavy traffic areas, condensers load with dirt more quickly. Failure to keep the condenser clean can result in equipment warm-up or erratic temperatures. ▲



**Caution** Never clean around the condensers with your fingers. Some surfaces are sharp. ▲

## Defrost Chamber



1. Remove all product and place it in another freezer.
2. Turn the unit off and disconnect it from the power source.
3. Turn off the battery switch (O). See Figures 5-1 and 5-2.
4. Open the lid and remove sub-lids. Place towels on the chamber floor.
5. Allow the frost to melt and become loose. Remove with a soft cloth.
6. After defrosting is complete, clean the interior with a non-chloride detergent. Rinse thoroughly with clean water and dry with a soft cloth.
7. Plug unit in and turn power switch on.
8. Turn the battery power switch to Standby mode (Ⓞ).
9. Allow the freezer to operate empty overnight before reloading the product.



**Caution** When defrosting your freezer, never use sharp or heavy tools such as chisels or scrapers. Damage to the equipment can result. Let the ice melt enough so that it can be easily removed. ▲

## Clean Lid Gasket

The lid gasket should be cleaned a minimum of once per month. Using a soft cloth, remove any frost build-up from the gasket, sub-lids and lids. The clean gasket alarm occurs every three months as a reminder to remove frost build-up from the gasket and doors. Press the Silence key to mute the audible alarm. The lid gasket may need to be cleaned more frequently if dirt or excessive frost build-up prevents the door from closing properly.

## Replace Battery(s)

The following instructions describe the battery replacement procedure for specific models.

### All Models Except 3 cu ft

1. Open the lower panel door by grasping the handle and pulling.
2. Locate the battery power switch (Figure 5-1). Turn the battery power switch to the Off position (O).
3. Remove the four screws holding the recorder bezel to gain access to the battery.
4. Remove the three nuts securing the battery bracket. See Figure 5-1.
5. Remove the bracket and old battery. Discard properly. Install the new battery and secure.
6. Reconnect the battery (red to positive and black to negative).
7. Replace the recorder bezel.
8. Turn the battery power switch to Standby mode (⏻).
9. Close lower panel door.

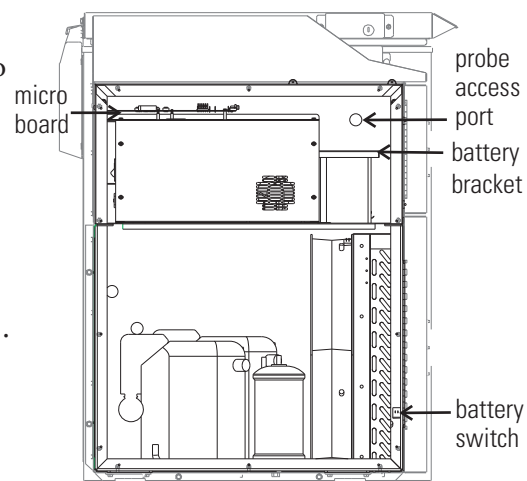


Figure 5-1. Battery and Switch location

### 3 cu ft Models

1. Open the lower panel door by locating the handle on the underside of the lower panel door and pulling.
2. Locate the battery power switch (Figure 5-2). Turn the battery power switch to the Off position (O).
3. Remove the two nuts securing the battery bracket. See Figure 5-2.
4. Remove the bracket and old battery. Discard properly. Install the new battery and secure.

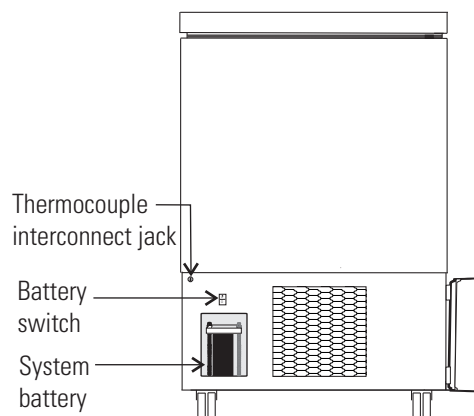


Figure 5-2. Battery and Switch location

### 3 cu ft Models (cont.)

5. Reconnect the battery (red to positive and black to negative).
6. Replace the recorder bezel.
7. Turn the battery power switch to Standby mode (⏻).
8. Close lower panel door.

**Note** For a consistent and dependable charge, replace the battery every 2 years. Replacement batteries must be rechargeable 12 V Lead Acid and are available from Thermo. Refer to the parts list for stock number and description of the replacement batteries (P/N 400159). Dispose of the used batteries in a safe manner and in accordance with good environmental practices. ▲

### Check Battery(s)

All Models except 3 cu ft (Figure 5-1):

1. Locate the power switch on the back of the unit. Turn the switch off. (O).
2. Open the lower door on the front left corner of the sidecar. Turn off the battery switch (O).
3. Remove all the screws from the side panel, except the lower ones. Just loosen these and lift the panel off.
4. The battery is rectangular in shape, located above the compressor compartment, to the right and behind the relay box. Remove the three wingnuts that secure the cover on the battery. Remove the cover.
5. Remove the battery from the mounting bracket.
6. Disconnect the red and black wires from the battery.
7. Use a voltmeter set to DC volts. Matching the wire colors, connect the meter to the battery.
8. If the voltage reads less than 10.8 volts, replace the battery. If above 10.8, re-install as previously.
9. Re-install side panel. Turn the battery power switch to Standby mode (⏻), then close lower door. Turn power switch On.

## Check Battery(s) (continued)

3 cu ft Models (Figure 5-2):

1. To gain access to the battery, open the lower door by grasping the bottom left corner. The battery is rectangular in shape, located on the left side of the filter compartment.
2. Directly above the battery(s) is the battery power switch. Turn the battery power switch to the off position (O).
3. Remove the three wingnuts that secure the cover on the battery. Remove the cover.
4. Remove the battery from the mounting bracket.
5. Disconnect the red and black wires from the battery.
6. Use a voltmeter set to DC volts. Matching the wire colors, connect the meter to the battery.
7. If the voltage reads less than 10.8 volts, replace the battery. If above 10.8, re-install as previously.
8. Turn the battery power switch to Standby mode (Ⓞ).
9. Close lower door.

## Prepare Unit for Storage



Defrost the unit as previously described. This prepares the unit for storage. Turn Off the battery power switch (O). Turn Off the freezer power switch.

**Caution** If the unit has been in service, turn it off and disconnect the power cord connector before proceeding with any maintenance. ▲

**PREVENTIVE MAINTENANCE**

**Freezers**

Your equipment has been thoroughly tested and calibrated before shipment. Regular preventive maintenance is important to keep your unit functioning properly. The operator should perform routine cleaning and maintenance on a regular basis. For maximum performance and efficiency, it is recommended that the unit be checked and calibrated periodically by a qualified service technician.

The following is a condensed list of preventive maintenance requirements. See the specified section of the instruction manual for further details.

We have qualified service technicians, using NIST traceable instruments, available in many areas. For more information on Preventive Maintenance or Extended Warranties, please contact the Technical Services Department.

Cleaning and calibration adjustment intervals are dependent upon use, environmental conditions and accuracy required.

**Tips:**

- Fill an upright by starting at the bottom near the probe and add racks to one shelf at a time. Allow freezer to recover to set point between shelves.
- Fill a chest by starting at the left side near the probe. Filling with room temperature racks will result in a long pull-down time.
- Fill unit with frozen product to help overall performance; frozen water jugs, for example.
- Always make certain the vacuum relief port is free of frost and ice, to allow for timely re-entry into the freezer after a door opening.

Action	Monthly	Yearly	Every 2 Years
Verify ambient temperature, <90°F	✓		
Check and clean probe cover, gaskets, hinges and lid(s) of ice and snow. See Figure 1-5 for probe location. See "Clean Lid Gasket".	✓ <i>More frequent cleaning may be required, depending on use and environmental conditions.</i>		
Check air filter. Clean or replace as needed. See "Clean Air Filter".		✓ 4X	
Check alarm back-up battery. See "Connect Unit to Electrical Power" in Section 1 and "Replace Battery" in Section 5.	✓		**Replace
Check condenser fan motor for unusual motor noise or vibration.		✓	
* Verify and document calibration, at the minimum, annually. See Section 2 Calibration.			
* Clean condenser compartment and vacuum off condenser. See "Clean Condenser" in Section 5.		✓	
Preventive Maintenance *Back-up System - inject test & battery. See Section 6.	✓		

✓\* *Qualified service technicians only*

\*\* *Dispose of properly, according to all state and federal regulations.*

## Section 6 Factory Installed Options

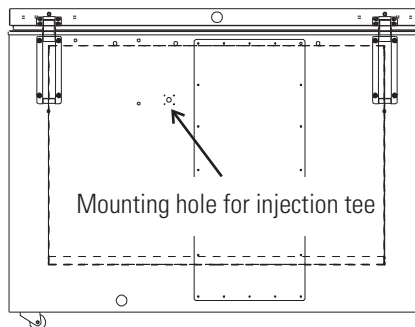
### Back Up System (BUS) - P/N 1960445, 1960447

**Note** Before installation of BUS components, make sure the power to the freezer is disconnected, the battery switch is turned off (O) and the freezer has warmed to ambient temperature. ▲

The built-in BUS (back up system) will keep the freezer chamber temperature below the critical level in the event of a power or equipment failure. If power to the freezer fails, or temperature increases to the back up alarm set point, the BUS injects liquefied gas into the chamber to keep the chamber temperature within the specified range.

### Install Injection Assembly

The BUS operates on an internal 12-volt, rechargeable battery which is kept charged during normal operation by the integral battery charger.



**Figure 6-1.** Mounting location

1. Locate the mounting hole for installing the injection tee assembly. See Figure 6-1.

**Note** Cover open end of injection assembly with tape to keep insulation from entering the nipple. ▲

2. Slide 3/8" flatwasher over open end of nipple.
3. Insert the covered end of the injection assembly through exterior hole.

## Install Injection Assembly (cont.)

4. Remove the tape covering the end of the nipple and install the 1/8" NPT brass tee on the open end of the nipple. Place Permagum sealant between the brass tee and the interior top.
5. Go to the interior and seal around injection assembly with Permagum.

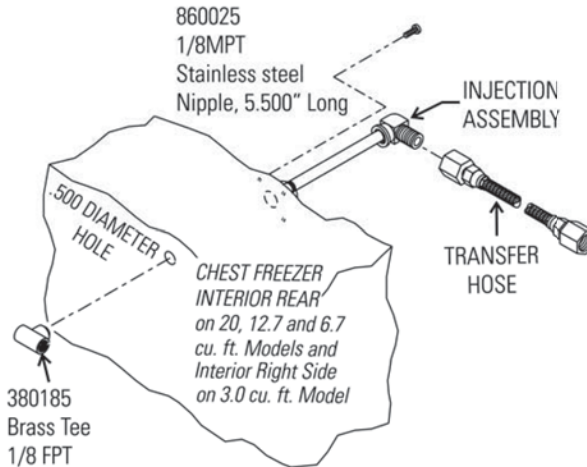


Figure 6-2. Injection Assembly

6. Install the transfer hose connecting one end to the injection assembly, the other end to the solenoid valve. Install the solenoid valve to the supply source. The solenoid mounting bracket is not required and may be discarded.

**Note** When selecting a CO<sub>2</sub> supply cylinder, it must be equipped with a siphon tube. ▲

## Install Temperature Probe

1. Plug the solenoid/probe connector into the BUS connection. Loop the probe wire back into the base/side car. Secure the connector with a screw on the ends of the connector. The connector is keyed.
2. Route the temperature probe through the probe port. The probe port is located in the upper right corner (viewed from the side) of 12.7 and 20 cu. ft. models, and in the lower right corner (viewed from the back) of 3.0 cu. ft. models.

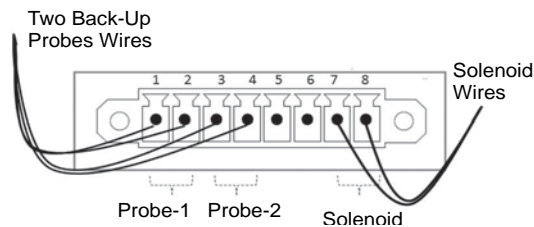
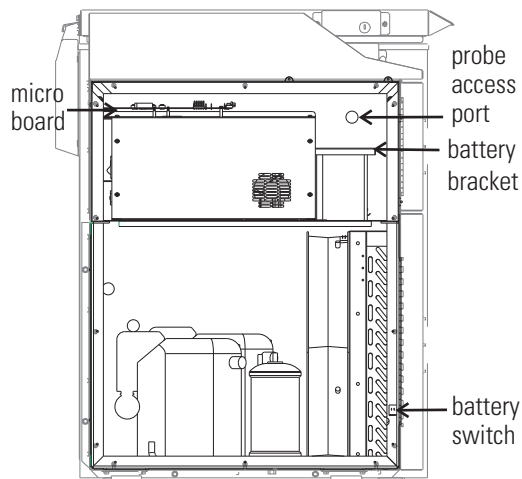


Figure 6-3. Probe and Solenoid Connections

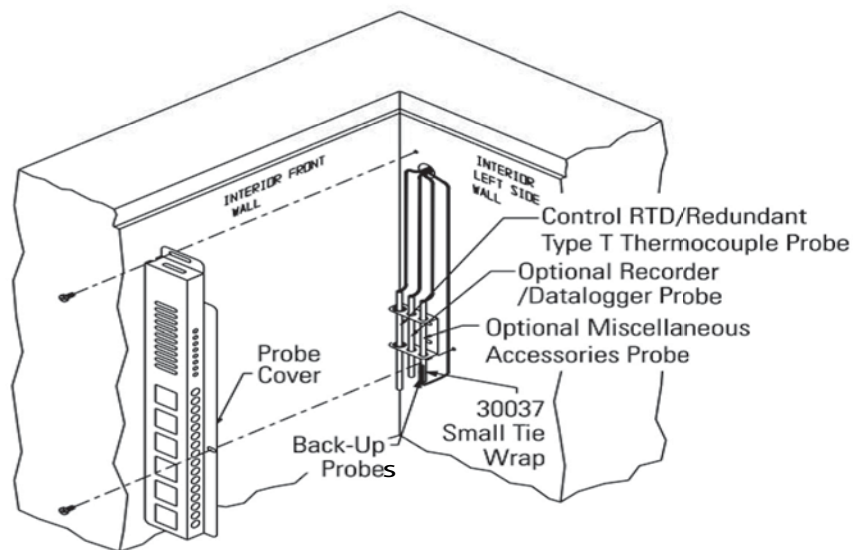
## Install Temperature Probe (cont.)

- Carefully remove the existing Permagum sealant from around the probe port opening.
- Open the freezer lid and locate the probe cover on the upper front left wall. Remove the two Phillips head screws securing the probe cover (see Figure 6-5).



**Figure 6-4.** Probe Access Port

- Route the BUS probe through the probe port, approximately 12". Secure the back-up probes to the temperature probe using a small tie wrap (Figure 6-5).



**Figure 6-5.** Probe location

- Seal around the interior and exterior opening of the probe port with Permagum sealant.
- Reinstall the probe cover (Figure 6-5).



## Connect Probe/Solenoid Harness

1. Carefully coil the extra probe lead in the compressor compartment, and secure it to the compartment wall with a tie wrap and tie wrap anchor provided. Additional tie wraps and anchors may be used to secure the probe lead to the exterior back wall of the freezer.
2. Loosen the terminal screws on the solenoid. Slide the spade lug connectors under the screws and tighten to secure.
3. Connect power to the freezer. Turn the freezer On, with battery switch Off (O).

### a. Arming on Power On

The arming function occurs only one time at initial power-on. It may occur in 3 ways; BUS timeout arming, both sensors fail and BUS temperature sensor arming.

At power-on, the BUS shall perform a Hold-off period check. The BUS will not inject the refrigerant for a Hold-off period, calculated as follows:

#### Hold-off period:

- 12 hour is between 0 and +70°C
- 12 hour is between 0 and (BUS Setpoint - Hysteresis)
- 0 hours is below (BUS Setpoint - Hysteresis)
- 0 hours is temperature Out Of Range or both probes fail.

b. The Low Battery indicator may also illuminate.

4. Turn the battery switch to Standby mode (⏻) to charge both batteries.

## BUS Control Panel

The following section describes the configuration and operation of the BUS.



**Warning** When activated, this unit injects liquid nitrogen or carbon dioxide. Liquid nitrogen can cause serious freezing (frostbite) if it comes in contact with unprotected skin or eyes. Nitrogen suppresses oxygen levels and may cause suffocation if area is not well ventilated. Refer to Appendix A for the proper handling of liquid LN<sub>2</sub>. ▲

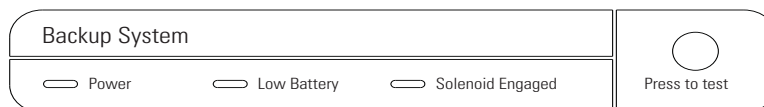
## BUS Control Panel (cont.)



**Caution** Make sure the pressure relief valve on any LN<sub>2</sub> tank is adjusted to 30 PSI maximum blow-off. ▲



**Warning** Carbon dioxide gas suppresses oxygen levels and may cause suffocation if area is not well ventilated. Refer to “Handling Liquid CO<sub>2</sub> in Appendix B of this manual. ▲



**Figure 6-6.** BUS Control Panel

**Power** - Indicates the unit has AC power.

### Normal Operation

- **Low Battery:** Illuminates only after a battery test which occurs every 8 hours. The battery test is a loaded test and during the test, the battery voltage is monitored. When the battery voltage is less than a certain threshold, this light will illuminate and stay illuminated until the next battery test.
- **Solenoid Engaged:** Illuminates any time the controller is activating the solenoid. Illumination will only occur when the controller senses the solenoid is active and calling for injection.

### Fault Code

This same user interface will also permit fault codes to be easily viewed when the user presses and releases the Press to Test button in less than 2 seconds. When this occurs, both the Low Battery LED and Solenoid Engaged LED will blink twice ON/OFF quickly indicating that fault code display mode is active. For the next ~10 seconds, the fault codes will be displayed as shown in the table below. The display shows only the lower number fault code until that fault is resolved.

**Table 6-1.** BUS Fault Codes

Low Battery LED	Solenoid Engaged LED	Fault Code Number	Fault Code Definition
OFF	OFF	0	Normal Operation
OFF	Blinks 1 time	1	Primary Probe Failure
OFF	Blinks 2 times	2	Secondary Probe Failure
OFF	Blinks 3 times	3	Solenoid Driver Failure
OFF	Blinks 4 times	4	Low Tank

Each blink will take one second, with half of the second interval being ON (illuminated) and the other half of the second interval being OFF. After the sequence concludes, both the Low Battery LED and the Solenoid Engaged LED will flash four times ON/OFF quickly to indicate a return to normal display.

## BUS Control Panel (cont.)

### BUS Injection Test

The user must press and hold the Press-to-Test button for  $\geq 2$  seconds before injection occurs. After the Press-to-Test button is pressed for  $>30$  seconds, the solenoid will turn off. This will avoid a button or button signal becoming stuck in an active condition.

During a Press-to-Test injection, if either RTD #1 or RTD #2 reads a temperature less than  $20^{\circ}\text{C}$  below BUS set point and it is determined to be a valid input, then injection will terminate immediately.

### BUS Set point “Validation” Feedback

Whenever the BUS set point or working fluid changes, the BUS acknowledges the set point acceptance by causing the Low Battery LED and Solenoid Engaged LED to blink three times ON/OFF quickly. This does not imply that the BUS error-checked the values, other than that the value received was within the range of the BUS working correctly with prior programming.

**Note** The solenoid will not engage if lid is open. ▲



**Caution** The back-up system is designed to inject  $\text{CO}_2$  or  $\text{LN}_2$ . In the unlikely event of both probes failing, the back-up system will operate in PWM or Non-PWM mode based on jumper settings as per Note below.

**Note** PWM mode: If both probes fail, the solenoid will activate periodically, allowing the flow of refrigerant ( $\text{CO}_2$  or  $\text{LN}_2$ ).

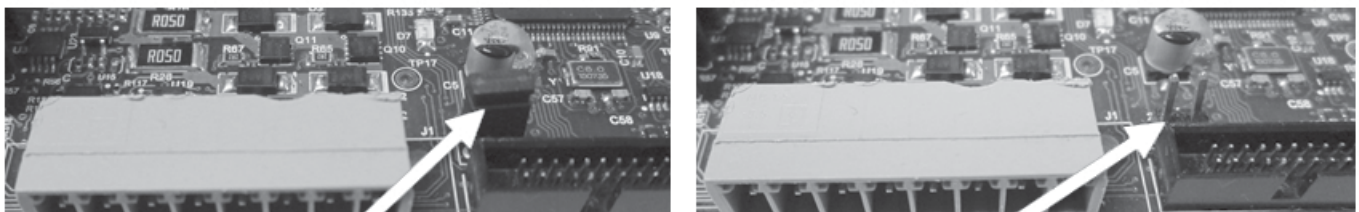
Non-PWM mode: If both probes fail, the solenoid remains OFF and no refrigerant will flow.

For Hysteresis & Dual probe fault mode settings (Figure 6-7), locate Jumper J17 near to solenoid/ sensor connector (J1), refer to table below for operation details:

**Table 6-2.** Probe Fault Mode Settings

Jumper PIN	Status	Hysteresis	Dual Probe Fault Mode
J17 PIN 1 & PIN 2	Short Together/ Jumper Cap Installed	$5^{\circ}\text{C}$	Non-PWM Mode
J17 PIN 1 & PIN 2	Open/No-Jumper Installed	$9^{\circ}\text{C}$	PWM Mode

**Figure 6-7.** Jumper Cap for Hysteresis & Dual Probe Fault Mode Selection



## Configure Optional Back Up System (BUS)

The optional BUS can be configured for LN<sub>2</sub> or CO<sub>2</sub> supply. Section 3 - Configuration contains instructions for setting the BUS type.

### Set Optional BUS Set Point

The optional back up system is designed to inject CO<sub>2</sub> or LN<sub>2</sub> into the freezer compartment if the temperature rises above back up system set point. To set the BUS set point:

1. Press the Mode key until the Settings indicator lights.
2. Press right arrow until "BACKUP = -XX" displays in message center.
3. Press up or down arrow key until desired BUS set point is displayed.
4. Press Enter to save the setting.
5. Press the Mode key until the Run indicator lights, or press the right or left arrow to go to the next or previous parameter.

If no control keys are pressed, the freezer will automatically return to RUN mode after 5 minutes.



**Warning** Changing operating temp set point can affect BUS set point. BUS set point self adjusts to maintain a temp of at least 10°C above the operating temp set point. ▲

**Note** The BUS set point cannot be set any colder than the high temperature alarm set point. (See Section 1 - Setting the High Temperature Alarm). If the back-up system is installed with CO<sub>2</sub>, then -65°C is the coldest BUS set point that can be used (if the cabinet set point is -75°C or colder). ▲

Program	From	To
1	-40	30°C
2	0	60°C
3	-100	38°C
4	-5	50°C
5	0	100°C
6	-100	200°C
7	-115	50°C
8	-10	70°C

### Test the BUS Operation

After the freezer has stabilized and both batteries are fully charged, the BUS can be tested to verify proper operation.

**Caution** Disconnect the AC power to the freezer by turning power switch off. ▲

1. As the freezer warms up, verify the BUS injects at the desired temperature. Displayed temperature may vary by a few degrees from inject temperature due to the differences in probe locations.

## Test the BUS Operation (cont.)

2. **Preventive Maintenance** - Monthly maintenance action to check CO<sub>2</sub> or LN<sub>2</sub> back-up system operation, alarms and battery voltage. Check for fault codes on the BUS probe per Table 6-1. Also verify solenoid operation by performing a Press-To-Test.

## Disconnect Fitting Assembly, Transfer Hose

To disconnect the freezer back-up from the gas supply:

1. Close the supply valve.
2. Depress the test button on the Back-Up System control box to remove the gas from the line.
3. Slowly disconnect the fitting assembly from the supply (in the event that any gas remains in the line).

## Chart Recorder

The following section describes the set up and operation of the optional chart recorder.

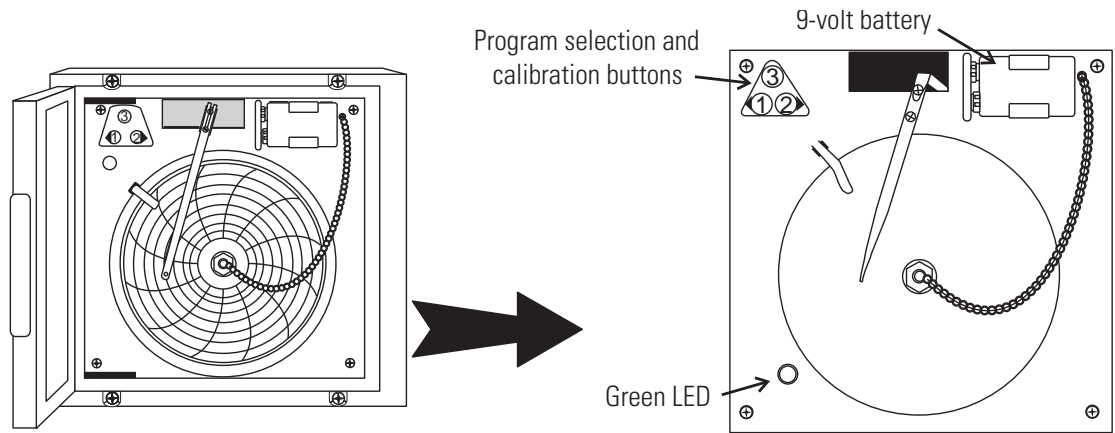


Figure 6-8. Recorder Details

## Install Chart Paper

1. Open the plastic door of the recorder and press button #3 until the pen begins to move outward.
2. Unscrew the knob at the center of the chart and remove the paper.
3. Install the new chart paper, position the paper to the correct time line and replace the knob.
4. Remove the cap from the felt pen and press button #3.

**Caution** Do not use sharp or pointed objects to depress the chart buttons. This may cause permanent damage to the recorder. ▲

**Caution** Be careful not to pull up on the chart recorder arm while changing paper. Pulling on the arm may damage the recorder. ▲

## Change Program

The chart recorder contains eight temperature ranges and is factory-programmed for the freezer. To change the recorder range:

1. Press and hold button #3 for one second, then let the pen move off the chart paper.
2. Press and hold for five seconds either button #1 or button #2.
3. Release the button and the green LED will begin to flash. Count the number of flashes to determine the present program setting.
4. To change the program setting, press the left or right arrows to increase or decrease the count.
5. When the desired program number is flashing, press button #3 to bring the pen arm back onto the chart. Recording will begin in the new program.

## Calibrate Chart Recorder

The recorder must be in service for 24 hours before performing the following calibration procedure.

1. Place an accurate thermometer in the chamber next to the recorder probe.
2. Temperature probes for the recorder are located in the left front corner of the freezer chamber (Figure 1-4).
3. After about three minutes, compare the thermometer reading with the chart recorder reading.
4. If an adjustment is necessary, press the #1 button to move the pen to the left or the #2 to move the pen to the right. The button must be held about five seconds before the pen begins to move. Release the button when the pen position matches the thermometer.

**Note** The felt-tip pen on the recorder requires periodic replacement. Usually the ink will appear to fade before replacement becomes necessary. Additional pen tips may be purchased from Thermo. ▲

## Section 6

### Factory Installed Options

## Section 7 Specifications

Number	803CA	803CV
Temperature Range	-50°C(-58°F) to -86°C(-123°F) in an 18°C to 32°C * (64.4F to 89.6F) ambient	
Exterior Dimensions	28.5" W x 43.8" H x 29.9" F-B (72.4 cm x 111.3 cm x 75.9 cm) Add 7.9" (20.1 cm) to F-B for wall spacer/handle.	
Interior Dimensions	18.5" W x 16.5" H x 18.5" F-B (47.0 cm x 41.9 cm x 47.0 cm)	
Capacity	3.0 cu. ft. (84.9 liters)	
Refrigeration	Cascade system, (2) hermetically-sealed compressors	
Insulation	Non CFC, foamed-in-place urethane: 5.0" (12.7 cm) cabinet; 2.0" (5.0 cm) lid; 1.0" (12.5 cm) sub-lids	
Electrical - nominal voltage ±10%	120 VAC, 1 PH, 60 Hz, 10.5	230 VAC, 1 PH, 50 Hz, 5.4
Breaker Requirements	15 Amp Dedicated Circuit, 15 Amp Time Delay Breaker	15 Amp Dedicated Circuit, 15 Amp Time Delay Breaker
Shipping Weight	432 lbs. (196 kg)	

Number	813CV	813CD	813CA
Temperature Range	-50°C(-58°F) to -86°C(-123°F) in an 18°C to 32°C * (64.4°F to 89.6°F) ambient		
Exterior Dimensions	72.0" W x 40.5" H x 33.4" F-B (182.9 cm x 102.9 cm x 84.8 cm) Add 7.9" (20.1 cm) to F-B for wall spacer/handle.		
Interior Dimensions	42.5" W x 28.0" H x 18.5" F-B (108.0 cm x 71.1 cm x 47.0 cm)		
Capacity	12.7 cu. ft. (360 liters)		
Refrigeration	Cascade system, (2) hermetically-sealed compressors		
Insulation	Non CFC, foamed-in-place urethane: 5.0" (12.7 cm) cabinet; 2.0" (5.0 cm) lid; 1.0" (12.5 cm) sub-lids		
Electrical - nominal voltage ±10%	230 VAC, 1 PH, 50 Hz, 12.0	208-230 VAC, 1 PH, 60 Hz, 12.0	120 VAC, 1 PH, 60 Hz, 16.0
Breaker Requirements	15 Amp Dedicated Circuit, 15 Amp Time Delay Breaker	15 Amp Dedicated Circuit, 15 Amp Time Delay Breaker	20 Amp Dedicated Circuit, 20 Amp Time Delay Breaker
Shipping Weight	716 lbs. (325 kg)		



**Section 7**  
Specifications

<b>Number</b>	<b>817CA</b>	<b>817CV</b>	<b>817CD</b>
<b>Temperature Range</b>	-50°C(-58°F) to -86°C(-123°F) in an 18°C to 32°C * (64.4°F to 89.6°F) ambient		
<b>Exterior Dimensions</b>	87.6" W x 40.5" H x 33.8" F-B (222.5 cm x 102.9 cm x 85.9 cm) Add 7.9" (20.1 cm) to F-B for wall spacer/handle.		
<b>Interior Dimensions</b>	58.8" W x 28.0"H x 18.5" F-B (149.4 cm x 71.1 cm x 47.0 cm)		
<b>Capacity</b>	17.0 cu. ft. (481.4 liters)		
<b>Refrigeration</b>	Cascade system, (2) hermetically-sealed compressors		
<b>Insulation</b>	Non CFC, foamed-in-place urethane: 5.0" (12.7 cm) cabinet; 2.0" (5.0 cm) lid; 1.0" (12.5 cm) sub-lids		
<b>Electrical - nominal voltage ±10%</b>	120 VAC, 1 PH, 60 Hz, 16.0	230 VAC, 1 PH, 50 Hz, 12.0	208-230 VAC, 1 PH, 60 Hz, 12.0
<b>Breaker Requirements</b>	20 Amp Dedicated Circuit, 20 Amp Time Delay Breaker	15 Amp Dedicated Circuit, 15 Amp Time Delay Breaker	15 Amp Dedicated Circuit, 15 Amp Time Delay Breaker
<b>Shipping Weight</b>	821 lbs. (372 kg)		

<b>Number</b>	<b>820CV</b>	<b>820CD</b>	<b>820CA</b>
<b>Temperature Range</b>	-50°C(-58°F) to -86°C(-123°F) in an 18°C to 32°C * (64.4°F to 89.6°F) ambient		
<b>Exterior Dimensions</b>	96.0" W x 40.5" H x 33.4" F-B (243.8 cm x 102.9 cm x 84.8 cm) Add 7.9" (20.1 cm) to F-B for wall spacer/handle.		
<b>Interior Dimensions</b>	66.5" W x 28.0"H x 18.5" F-B (168.9 cm x 71.1 cm x 47.0 cm)		
<b>Capacity</b>	20.0 cu. ft. (566.3 liters)		
<b>Refrigeration</b>	Cascade system, (2) hermetically-sealed compressors		
<b>Insulation</b>	Non CFC, foamed-in-place urethane: 5.0" (12.7 cm) cabinet; 2.0" (5.0 cm) lid; 1.0" (12.5 cm) sub-lids		
<b>Electrical - nominal voltage ±10%</b>	230 VAC, 1 PH, 50 Hz, 12.0	208-230 VAC, 1 PH, 60 Hz, 12.0	120 VAC, 1 PH, 60 Hz, 16.0
<b>Breaker Requirements</b>	15 Amp Dedicated Circuit, 15 Amp Time Delay Breaker	15 Amp Dedicated Circuit, 15 Amp Time Delay Breaker	20 Amp Dedicated Circuit, 20 Amp Time Delay Breaker
<b>Shipping Weight</b>	833 lbs. (378 kg)		

<b>Number</b>	<b>703CA</b>	<b>703CV</b>
<b>Temperature Range</b>	-10°C (14°F) to -40°C (-40°F) in an 18°C to 32°C * (64.4F to 89.6F) ambient	
<b>Exterior Dimensions</b>	28.5" W x 43.8" H x 29.9" F-B (72.4 cm x 111.3 cm x 75.9 cm) Add 7.9" (20.1 cm) to F-B for wall spacer/handle.	
<b>Interior Dimensions</b>	18.5" W x 16.5"H x 18.5" F-B (47.0 cm x 41.9 cm x 47.0 cm)	
<b>Capacity</b>	3.0 cu. ft. (84.9 liters)	
<b>Refrigeration</b>	Hermetically-sealed compressor	
<b>Insulation</b>	Non CFC, foamed-in-place urethane: 5.0" (12.7 cm) cabinet; 2.0" (5.0 cm) lid; 1.0" (12.5 cm) sub-lids	
<b>Electrical - nominal voltage ±10%</b>	120 VAC, 1 PH, 60 Hz, 6.0	230 VAC, 1 PH, 50 Hz, 3.0
<b>Breaker Requirements</b>	15 Amp Dedicated Circuit, 15 Amp Time Delay Breaker	15 Amp Dedicated Circuit, 15 Amp Time Delay Breaker
<b>Shipping Weight</b>	395 lbs. (179 kg)	

<b>Number</b>	<b>713CV</b>	<b>713CD</b>	<b>713CA</b>
<b>Temperature Range</b>	-10°C (14°F) to -40°C (-40°F) in an 18°C to 32°C * (64.4°F to 89.6°F) ambient		
<b>Exterior Dimensions</b>	72.0" W x 40.5" H x 33.4" F-B (182.9 cm x 102.9 cm x 84.8 cm) Add 7.9" (20.1 cm) to F-B for wall spacer/handle.		
<b>Interior Dimensions</b>	42.5" W x 28.0"H x 18.5" F-B (108.0 cm x 71.1 cm x 47.0 cm)		
<b>Capacity</b>	12.7 cu. ft. (360 liters)		
<b>Refrigeration</b>	Hermetically-sealed compressor		
<b>Insulation</b>	Non CFC, foamed-in-place urethane: 5.0" (12.7 cm) cabinet; 2.0" (5.0 cm) lid; 1.0" (12.5 cm) sub-lids		
<b>Electrical - nominal voltage ±10%</b>	230 VAC, 1 PH, 50 Hz, 3.0	208-230 VAC, 1 PH, 60 Hz, 3.0	120 VAC, 1 PH, 60 Hz, 6.0
<b>Breaker Requirements</b>	15 Amp Dedicated Circuit, 15 Amp Time Delay Breaker	15 Amp Dedicated Circuit, 15 Amp Time Delay Breaker	20 Amp Dedicated Circuit, 20 Amp Time Delay Breaker
<b>Shipping Weight</b>	716 lbs. (325 kg)		

**Section 7**  
Specifications

<b>Number</b>	<b>717CA</b>	<b>717CD</b>	<b>717CV</b>
<b>Temperature Range</b>	-10°C (14°F) to -40°C (-40°F) in an 18°C to 32°C * (64.4°F to 89.6°F) ambient		
<b>Exterior Dimensions</b>	87.6.0" W x 40.5" H x 33.8" F-B (222.5 cm x 102.9 cm x 85.9 cm) Add 7.9" (20.1 cm) to F-B for wall spacer/handle.		
<b>Interior Dimensions</b>	58.8" W x 28.0"H x 18.5" F-B (149.4 cm x 71.1 cm x 47.0 cm)		
<b>Capacity</b>	17.0 cu. ft. (481.4 liters)		
<b>Refrigeration</b>	Hermetically-sealed compressor		
<b>Insulation</b>	Non CFC, foamed-in-place urethane: 5.0" (12.7 cm) cabinet; 2.0" (5.0 cm) lid; 1.0" (12.5 cm) sub-lids		
<b>Electrical - nominal voltage ±10%</b>	120 VAC, 1 PH, 60 Hz, 9.0	208-230 VAC, 1 PH, 60 Hz, 7.0	230 VAC, 1 PH, 50 Hz, 7.0
<b>Breaker Requirements</b>	20 Amp Dedicated Circuit, 20 Amp Time Delay Breaker	15 Amp Dedicated Circuit, 15 Amp Time Delay Breaker	15 Amp Dedicated Circuit, 15 Amp Time Delay Breaker
<b>Shipping Weight</b>	764 lbs. (347 kg)		

<b>Number</b>	<b>720CV</b>	<b>720CD</b>	<b>720CA</b>
<b>Temperature Range</b>	-10°C (14°F) to -40°C (-40°F) in an 18°C to 32°C * (64.4°F to 89.6°F) ambient		
<b>Exterior Dimensions</b>	96.0" W x 40.5" H x 33.4" F-B (243.8 cm x 102.9 cm x 84.8 cm) Add 7.9" (20.1 cm) to F-B for wall spacer/handle.		
<b>Interior Dimensions</b>	66.5" W x 28.0"H x 18.5" F-B (168.9 cm x 71.1 cm x 47.0 cm)		
<b>Capacity</b>	20.0 cu. ft. (566.3 liters)		
<b>Refrigeration</b>	Hermetically-sealed compressor		
<b>Insulation</b>	Non CFC, foamed-in-place urethane: 5.0" (12.7 cm) cabinet; 2.0" (5.0 cm) lid; 1.0" (12.5 cm) sub-lids		
<b>Electrical - nominal voltage ±10%</b>	230 VAC, 1 PH, 50 Hz, 6.5	208-230 VAC, 1 PH, 60 Hz, 6.5	120 VAC, 1 PH, 60 Hz, 10.0
<b>Breaker Requirements</b>	15 Amp Dedicated Circuit, 15 Amp Time Delay Breaker	15 Amp Dedicated Circuit, 15 Amp Time Delay Breaker	20 Amp Dedicated Circuit, 20 Amp Time Delay Breaker
<b>Shipping Weight</b>	776 lbs. (352 kg)		

**Certifications**

Declaration of Conformity is available upon request

**Safety Specifications**

Indoor Use Only

Altitude - up to 2,000 meters

Temperature - 5°C to 43°C

Humidity - Maximum RH 80% for temperatures up to 31°C, decreasing linearly to 50% RH at 40°C

Mains Supply Fluctuations - Mains supply voltage fluctuations not to exceed ±10% of the nominal voltage

Installation Category II <sup>1</sup>

Pollution Degree 2 <sup>2</sup>

Class of Equipment I

**Fluorinated Greenhouse Gases**

Compliant with REGULATION (EU) No 517/2014 OF THE EUROPEAN PARLIAMENT AND OF THE COUNCIL on fluorinated greenhouse gases.

This product contains fluorinated greenhouse gases in a hermetically sealed system. If a leak in the sealed system is detected, the operator shall repair without undue delay.

For ULT models rated 230 V/50 Hz, intended for import into the EU, the following sizes are designed for use with the following amounts of fluorinated greenhouse gases:

For -86°C rated units

Size (ft <sup>3</sup> )	1st Stage			2nd Stage		
	Refrigerant	Amount (kg)	GWP	Refrigerant	Amount (kg)	GWP
<b>3</b>	R-404a	0.232	3 922	R-508b	0.188	13 396
<b>12.7</b>	R-404a	0.737	3 922	R-508b	0.213	13 396
<b>17</b>	R-404a	0.737	3 922	R-508b	0.235	13 396
<b>20</b>	R-404a	0.737	3 922	R-508b	0.243	13 396

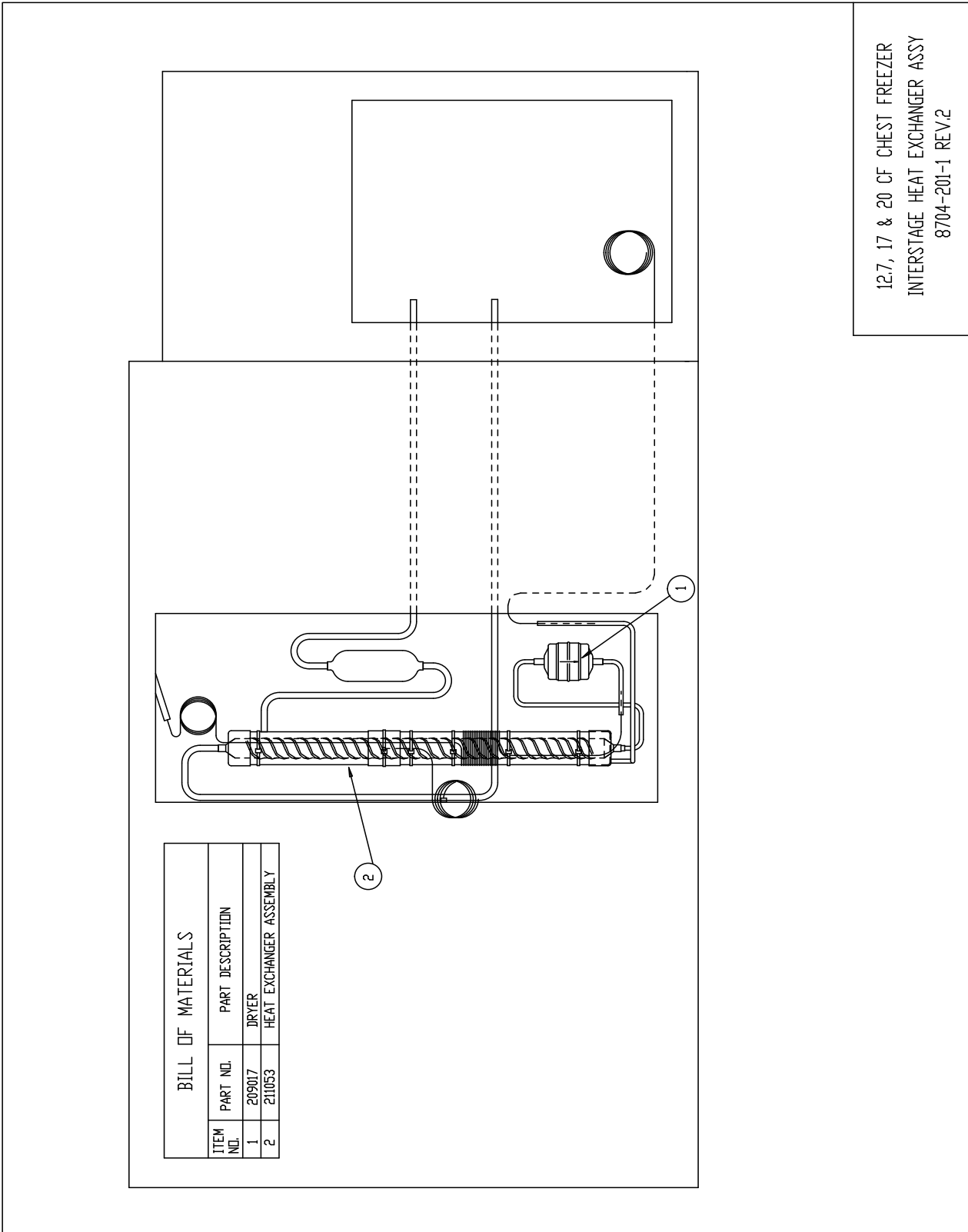
For -40°C rated units

Size (ft <sup>3</sup> )	1st Stage		
	Refrigerant	Amount (kg)	GWP
<b>3</b>	R-404a	0.425	3 922
<b>12.7</b>	R-404a	0.539	3 922
<b>17</b>	R-404a	0.595	3 922
<b>20</b>	R-404a	0.652	3 922

<sup>1</sup> Installation category (overvoltage category) defines the level of transient overvoltage which the instrument is designed to withstand safely. It depends on the nature of the electricity supply and its overvoltage protection means. For example, in CAT II which is the category used for instruments in installations supplied from a supply comparable to public mains such as hospital and research laboratories and most industrial laboratories, the expected transient overvoltage is 2500 V for a 230 V supply and 1500 V for a 120 V supply.

<sup>2</sup> Pollution degree describes the amount of conductive pollution present in the operating environment. Pollution degree 2 assumes that normally only non-conductive pollution such as dust occurs with the exception of occasional conductivity caused by condensation.

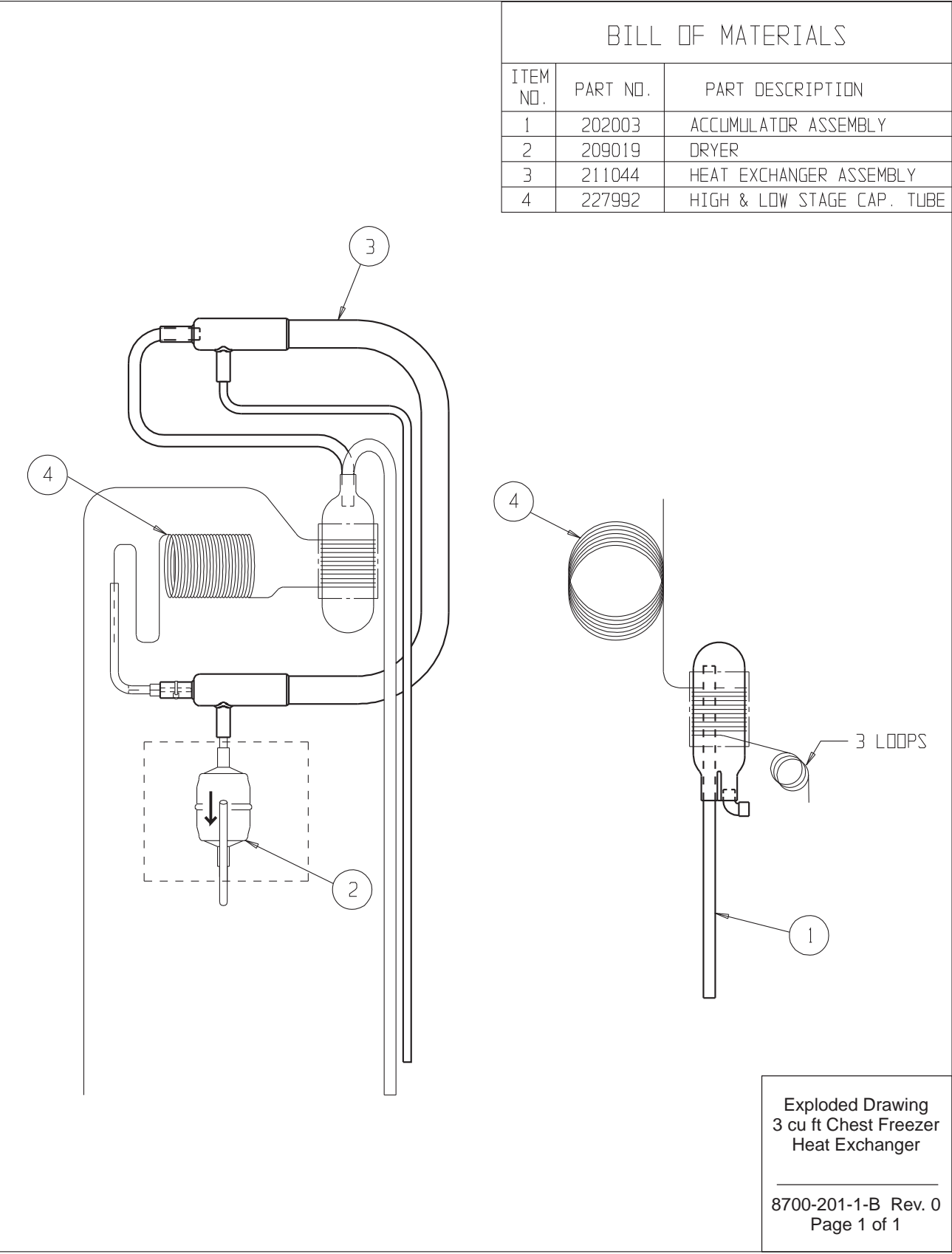
**Section 7**  
Specifications



12.7, 17 & 20 CF CHEST FREEZER  
INTERSTAGE HEAT EXCHANGER ASSY  
8704-201-1 REV.2

**Section 8**  
Spare Parts

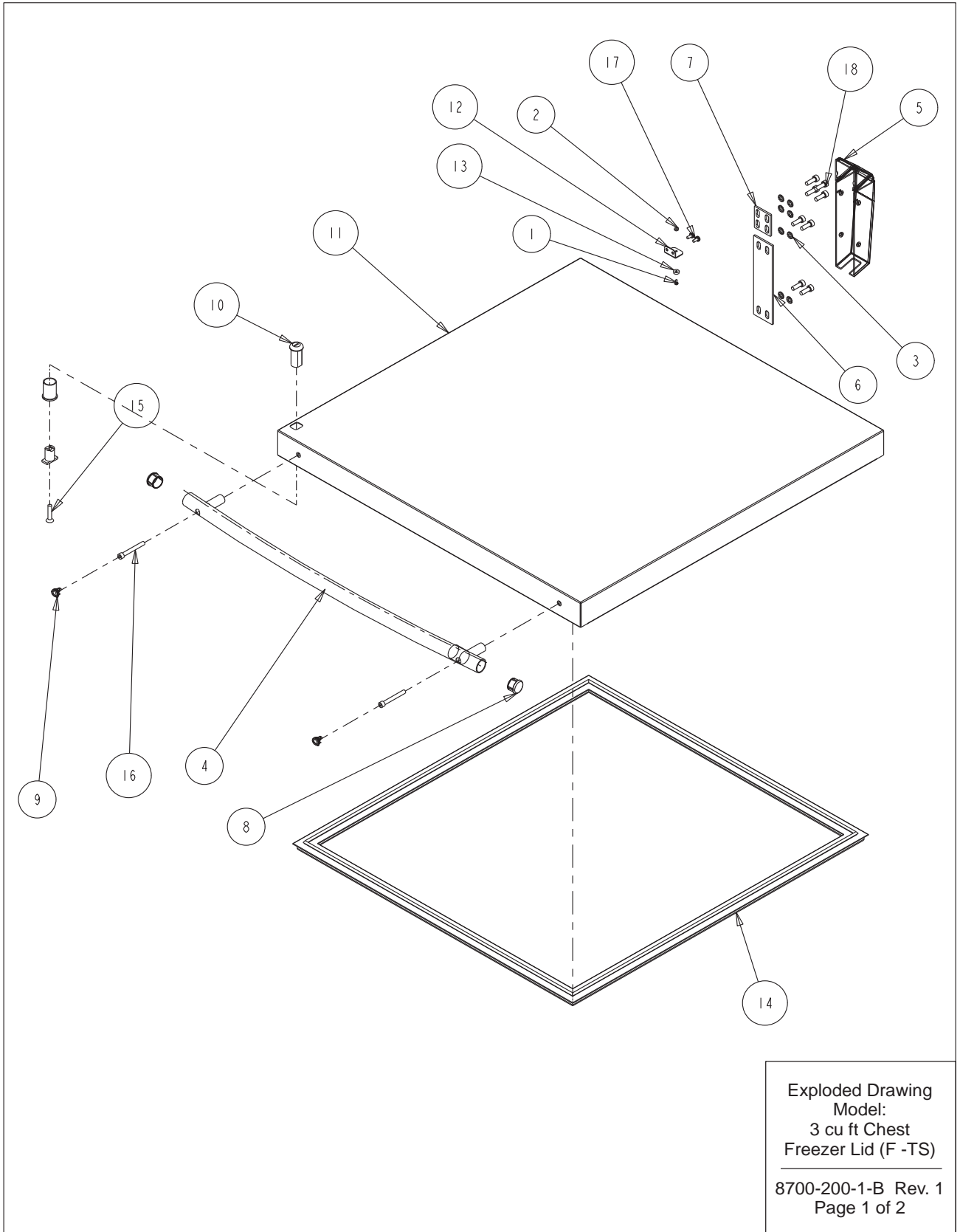
BILL OF MATERIALS		
ITEM NO.	PART NO.	PART DESCRIPTION
1	202003	ACCUMULATOR ASSEMBLY
2	209019	DRYER
3	211044	HEAT EXCHANGER ASSEMBLY
4	227992	HIGH & LOW STAGE CAP. TUBE



Exploded Drawing  
3 cu ft Chest Freezer  
Heat Exchanger

---

8700-201-1-B Rev. 0  
Page 1 of 1





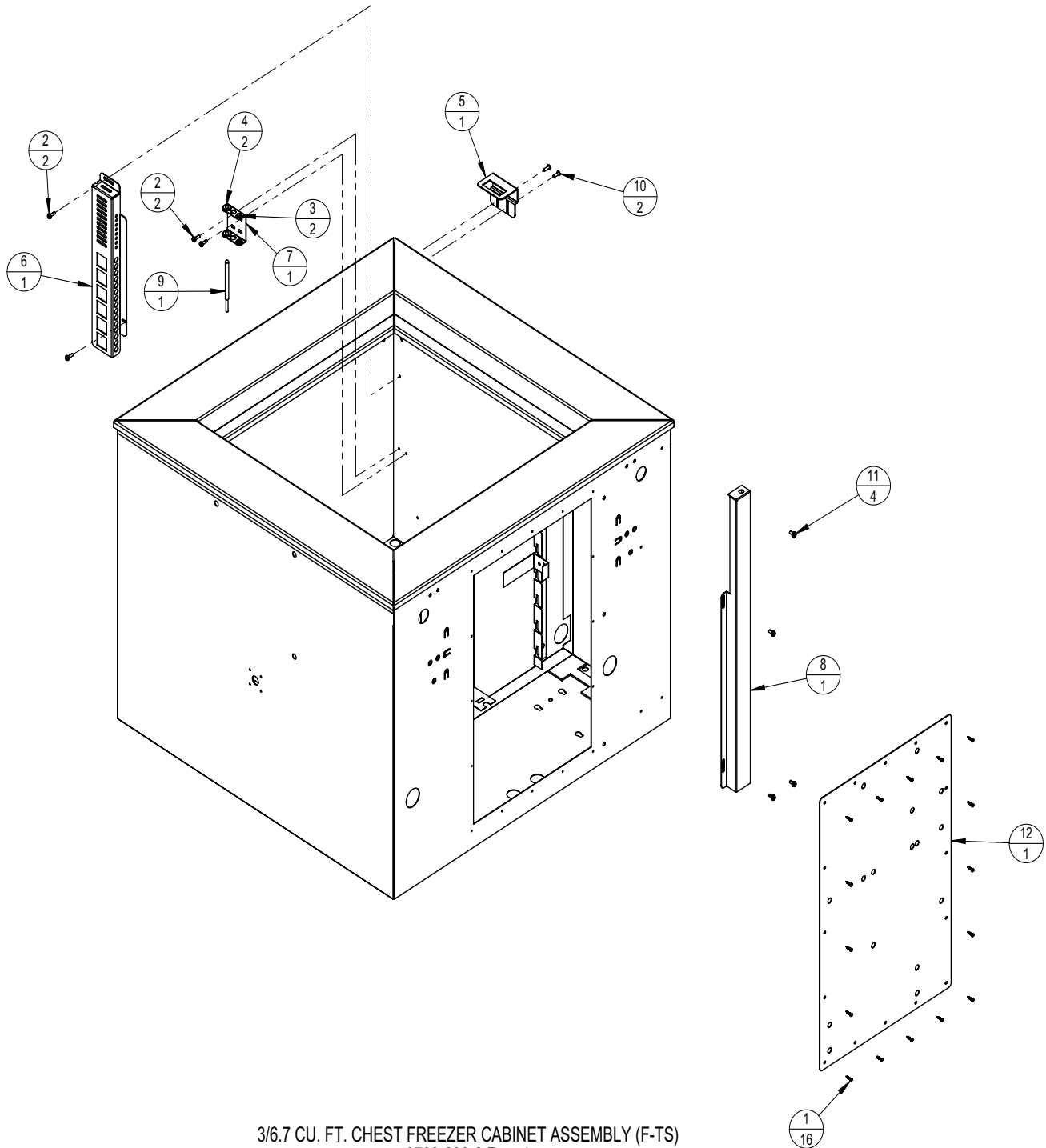
**Section 8**  
Spare Parts

BILL OF MATERIALS		
ITEM NO.	PART NO.	PART DESCRIPTION
1	22130	#4-40 X 1/4 SS PHP SCREW
2	23005	#4-40 SS HEX NUT
3	23062	1/4 SS EXT TOOTH LOCKWASHER
4	115038	646 SID BLUE RADIUSED HANDLE
5	116136	SPRING LOADED HINGE
6	116137	HINGE SHIM LAYOUT
7	116138	HINGE SHIM LAYOUT
8	180314	THERMO ULT CHEST HANDLE END CAP
9	180315	ULT CHEST HANDLE SCREW COVER
10	195332	LOCK MOUNT ASSEMBLY
11	195950	3.0 CU. FT. CHEST FREEZER LID
12	195970	3/6.7 LID SWITCH MAGNET MOUNT
13	360257	SWITCH MAGNET
14	431148	3.0 CU. FT. CHEST FREEZER LID GASKET
15	490023	#1/4-28 X 1-1/4 SS FHP SCREW
16	530027	1/4-20 X 2L SS HEX SOCKET CAP SCREW
17	590020	#8-32 X 3/8 SS PHP EXT SEMS SCREW
18	3176861	1/4-20 x 3/4 SOCKET HEAD SCREW

Exploded Drawing  
Model:  
3 cu ft Chest  
Freezer Lid (F -TS)

---

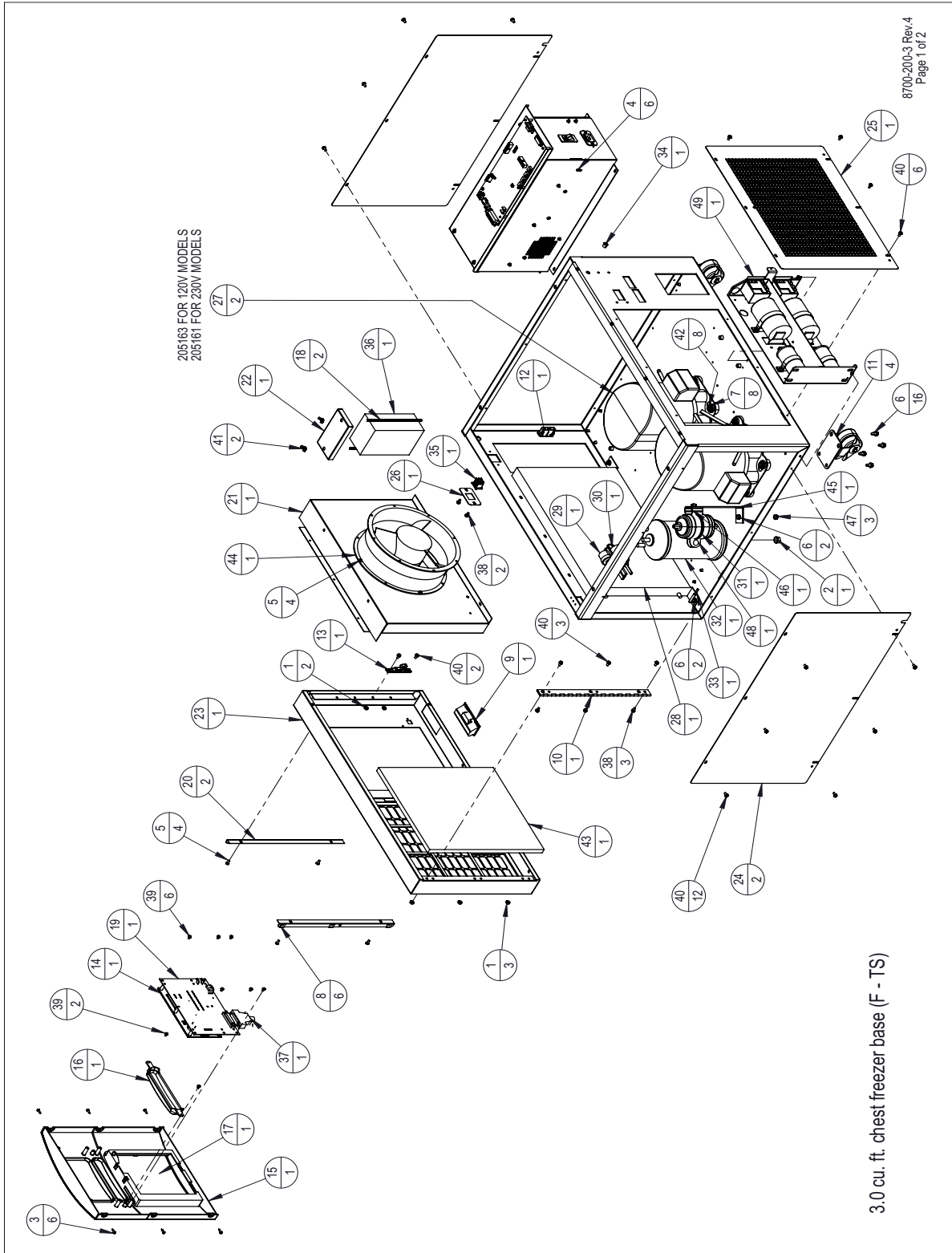
8700-200-1-B Rev. 1  
Page 2 of 2



3/6.7 CU. FT. CHEST FREEZER CABINET ASSEMBLY (F-TS)  
8700-200-2 Rev. 1  
Page 1 of 2

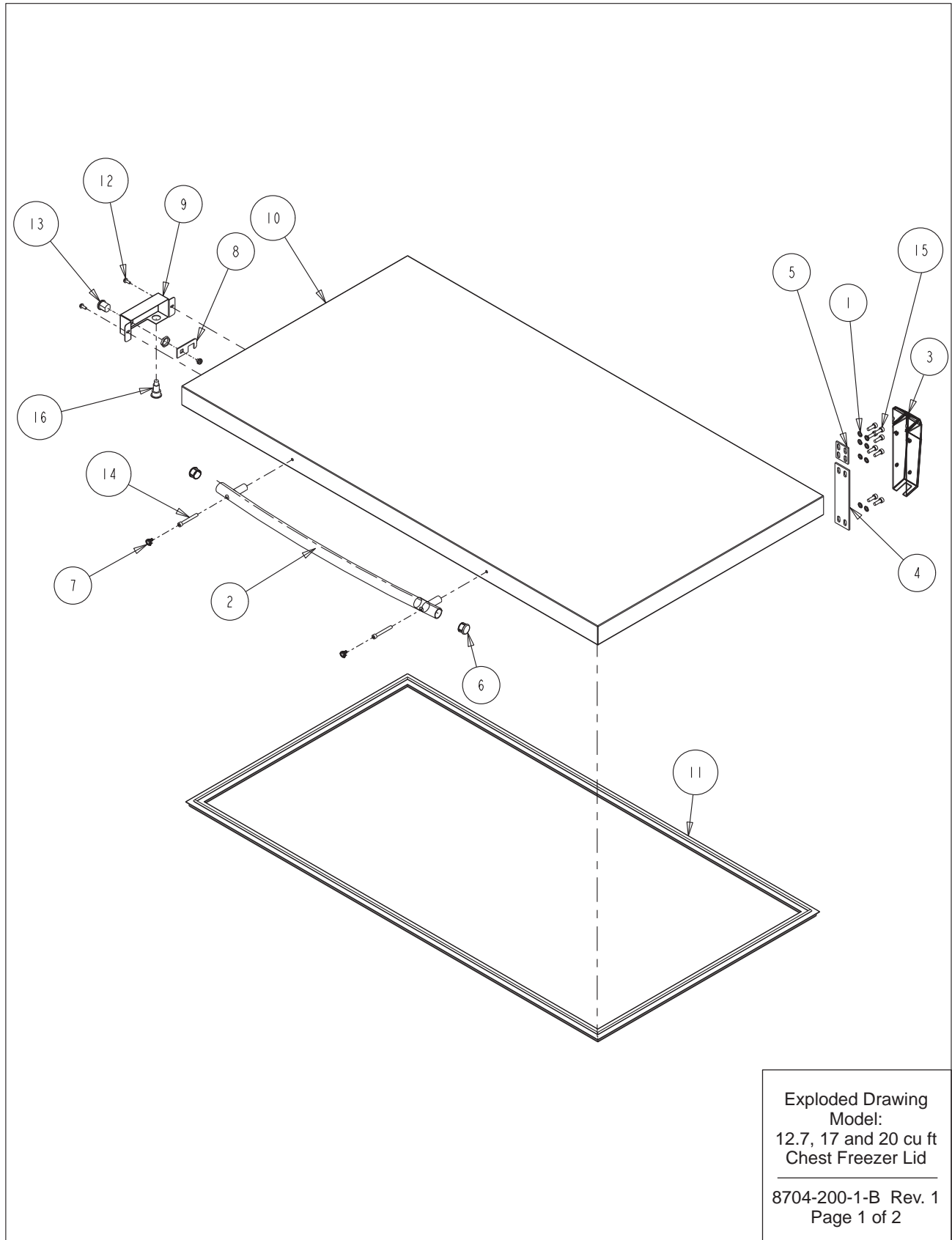
BILL OF MATERIALS		
ITEM NO.	PART NO.	PART DESCRIPTION
1	24030	#8 X 1/2" TEKS SCREW
2	24042	#8-32 X 1/2 SS PHP SCREW F POINT
3	30073	5/16" OD X 3/16" ID GROMMET
4	114020	5/8" X 1/2" ID GROMMET
5	189526	LID LOCK MOUNT LAYOUT
6	195866	PROBE GUARD
7	195867	PROBE MOUNT
8	195916	3/6.7 LID SWITCH BRACKET
9	290176	CONTROL PROBE
10	550022	#8-32 X 1/2L BUTTON HD TORX SCREW
11	590020	#8 - 32 X 3/8 SS PHP EXT SEMS SCREW
12	195622-34-1	REAR COVER PLATE

3/6.7 CU. FT. CHEST FREEZER CABINET ASSEMBLY (F-TS)  
8700-200-2 Rev. 1  
Page 2 of 2



BILL OF MATERIALS		
ITEM NO.	PART NO.	PART DESCRIPTION
1	23002	#8-32 ZP LKWASH HEX NUT
2	23013	3/8-16 ZP LKWASH HEX NUT
3	24016	#6 X 1/2" SS PHP SCREW AB POINT
4	24030	#8 X 1/2" TEKS SCREW
5	24032	#8-32 X 3/8 SS PHP SCREW F POINT
6	24038	1/4-20 X 1/2 SELF TAPPING SCREW
7	24049	1/4 ZP FLAT WASHER
8	25040	#6 U SPEED NUT STL. STL.
9	115032	BLACK ABS PLASTIC PULL
10	116115	FRONT PANEL HINGE
11	120011	DUAL WHEEL CASTER
12	121071	LATCH CATCH, PART OF 121071 ASSEMBLY
13	121071	LATCH KEEPER, PART OF 121071 ASSEMBLY
14	140452	CONTROL PANEL ASSEMBLY
15	180305	CONTROL CENTER DISPLAY BEZEL "SID BLU"
16	180306	THERMO BACK-UP SYSTEM BLANK PANEL "SID BLUE"
17	180308	CONTROL CENTER RECORDER BLANK "SID BLU"
18	191385	FILTER HOLD DOWN ROD
19	191953	FREEZER DISPLAY BOARD
20	195837	MOUNTING ANGLE FOR 180305
21	195923	3.0 & 6.7 CU. FT. CHEST FREEZER FAN SHROUD
22	195924	SINGLE BATTERY MOUNT BRACKET
23	195925	3.0 CU. FT. FRONT FILTER PANEL SUB-ASSEMBLY
24	195927	3.0 & 6.7 CHEST FREEZER SIDE PANEL
25	195928	3.0 CU.FT. CHEST REAR GRILLE
26	195931	3.0 & 6.7 CU. FT BATTERY SWITCH BRACKET
27	205163	L/S & H/S COMPRESSOR 120V
28	204001	CONDENSER W/DESUPERHEATER
29	207008	PRESSURE SWITCH
30	207010	PRESSURE SWITCH

BILL OF MATERIALS		
ITEM NO.	PART NO.	PART DESCRIPTION
31	209017	DRYER,C-052,1/4 ODS
32	214023	OIL SEPARATOR
33	290178	CONDENSER PROBE
34	330003	3/8" SPLIT SNAP BUSHING
35	360248	SWITCH, MINI SNAP IN POWER
36	400159	LEAD-ACID BATT. 12V 7AH
37	430336	15 FT, RS-232 CABLE 25 POS.
38	590020	SCREW, # 8-32X3/8, SS PHP
39	590027	SCREW, # 6-32X1/4 SS PHP
40	590029	#8-32 X 3/8 SS PHP EXT SEMS SCREW W/PATCH
41	610009	1/4-20 S.S. WING NUT
42	680017	1/4 - 20 X 1 - 1/4 SELF TAPPING SCREW
43	760211	3 AND 6.7 CU. FT. CHEST FREEZER AIR FILTER
44	900113	10" TUBEAXIAL FAN, 115V
45	1950850	FILTER DRIER MOUNTING BRACKET
46	200126	2" RIGID HANGER
47	23011	1/4-20 ZP LKWASH HEX NUT
48	550043	1/4-20 X 1" L ZP CARRIAGE BOLT
49	120230-01-1	CHEST FREEZER START COMPONENT ENCLOSURE ASSEMBLY

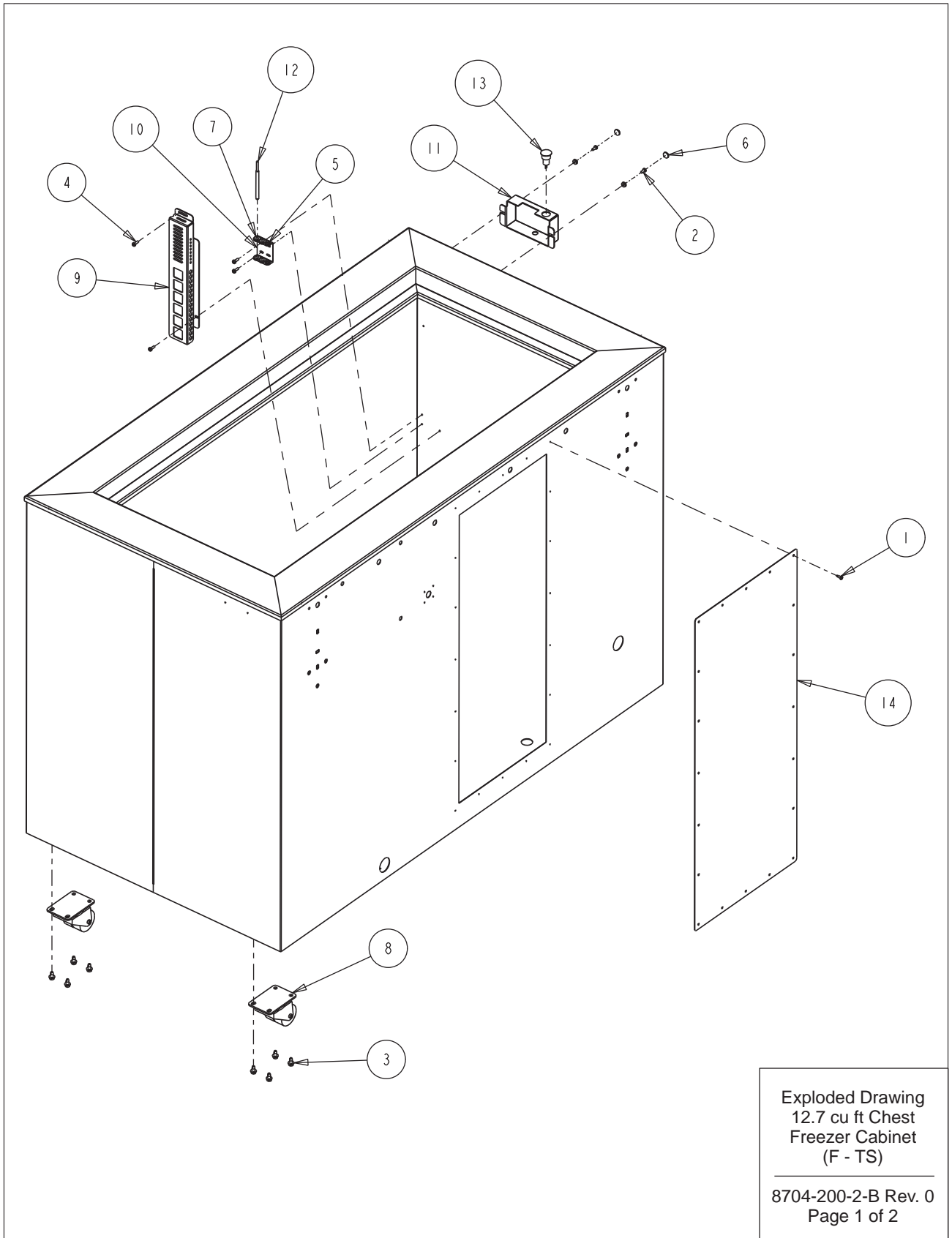


**Section 8**  
Spare Parts

BILL OF MATERIALS		
ITEM NO.	PART NO.	PART DESCRIPTION
1	23062	1/4 SS EXT TOOTH LOCKWASHER
2	115038	646 SID BLUE RADIUSED HANDLE
3	116136	SPRING LOADED HINGE
4	116137	HINGE SHIM LAYOUT
5	116138	HINGE SHIM LAYOUT
6	180314	THERMO ULT CHEST HANDLE END CAP
7	180315	ULT CHEST HANDLE SCREW COVER
8	189529	CHEST FREEZER LOCK STRIKE
9	195935	CHEST FREEZER LOCK MOUNT
10	195958	12.7 CU. FT. CHEST FREEZER LID
11	431133	12.7 CU. FT. CHEST FREEZER LID GASKET
12	510022	#10-32 X 1/2" LONG SLOTTED HEX HEAD SCREW
13	515070	PANEL MOUNT TUMBLER LOCK
14	530027	1/4-20 X 2L SS HEX SOCKET CAP SCREW
15	3176861	1/4-20 x 3/4 SOCKET HEAD SCREW
16	360256	MAGNETIC SWITCH MAGNET

FOR 17 CU. FT. MODELS - USE PART 195957 LID AND PART 990036 GASKET  
 FOR 20 CU. FT. MODELS - USE PART 195956 LID AND PART 431132 GASKET

Exploded Drawing  
 Model:  
 12.7, 17 and 20 cu ft  
 Chest Freezer Lid  
 8704-200-1-B Rev. 1  
 Page 2 of 2



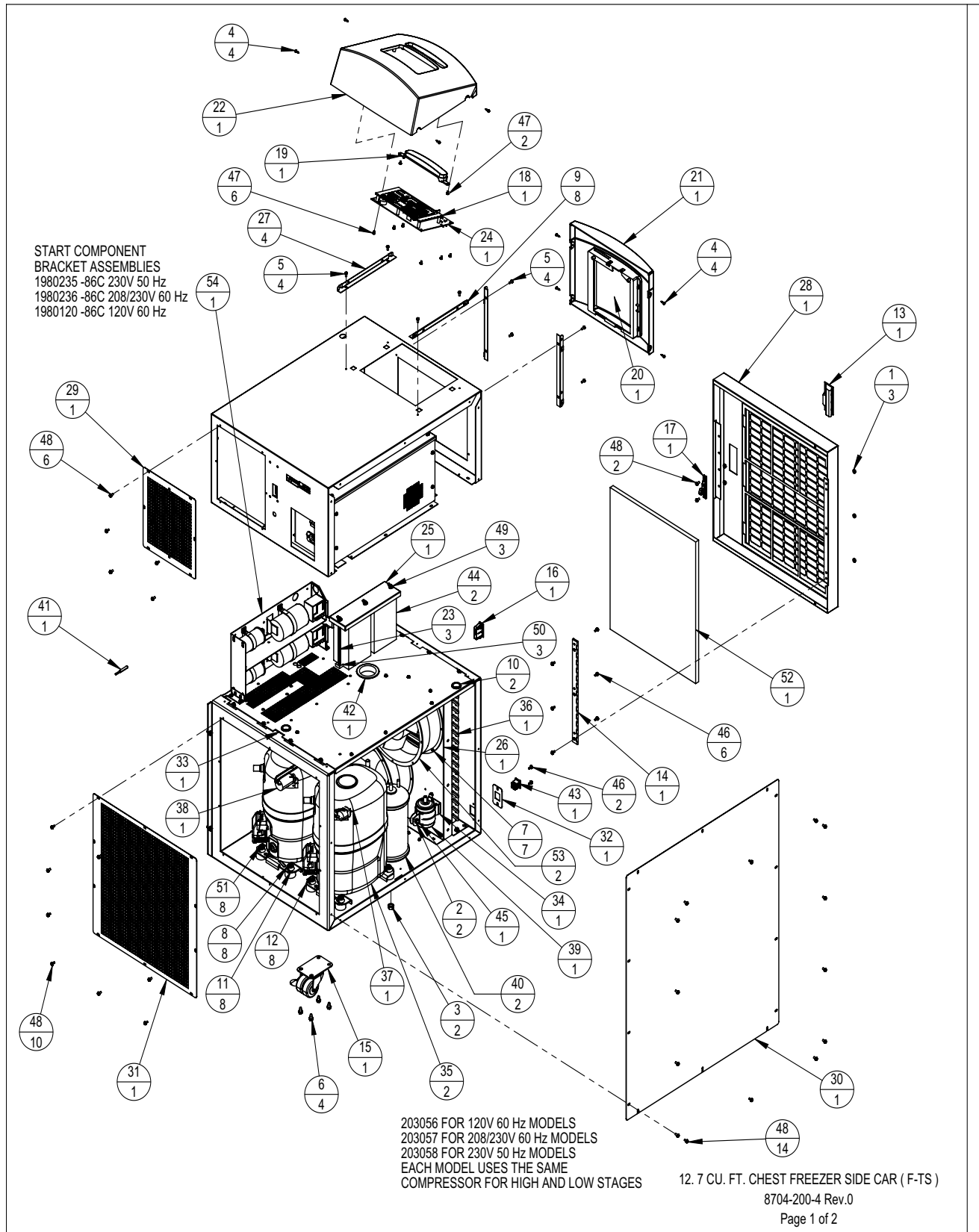


**Section 8**  
Spare Parts

BILL OF MATERIALS		
ITEM NO.	PART NO.	PART DESCRIPTION
1	24030	#8 X 1/2" TEKS SCREW
2	24032	#8-32 X 3/8 SS PHP SCREW F POINT
3	24038	1/4-20 X 1/2 SELF TAPPING SCREW
4	24042	#8-32 X 1/2 SS PHP SCREW F POINT
5	30073	5/16" X 3/16" ID GROMMET
6	110028	DECORATIVE SNAP CAP
7	114020	5/8" X 1/2" ID GROMMET
8	120011	DUAL WHEEL CASTER
9	195866	PROBE GUARD
10	195867	PROBE MOUNT
11	195936	LOCK CATCH
12	290176	CONTROL PROBE
13	360256	MAGNETIC SWITCH
14	195478-39-1	REAR COVER PLATE

Exploded Drawing  
12.7 cu ft Chest  
Freezer Cabinet  
(F - TS)

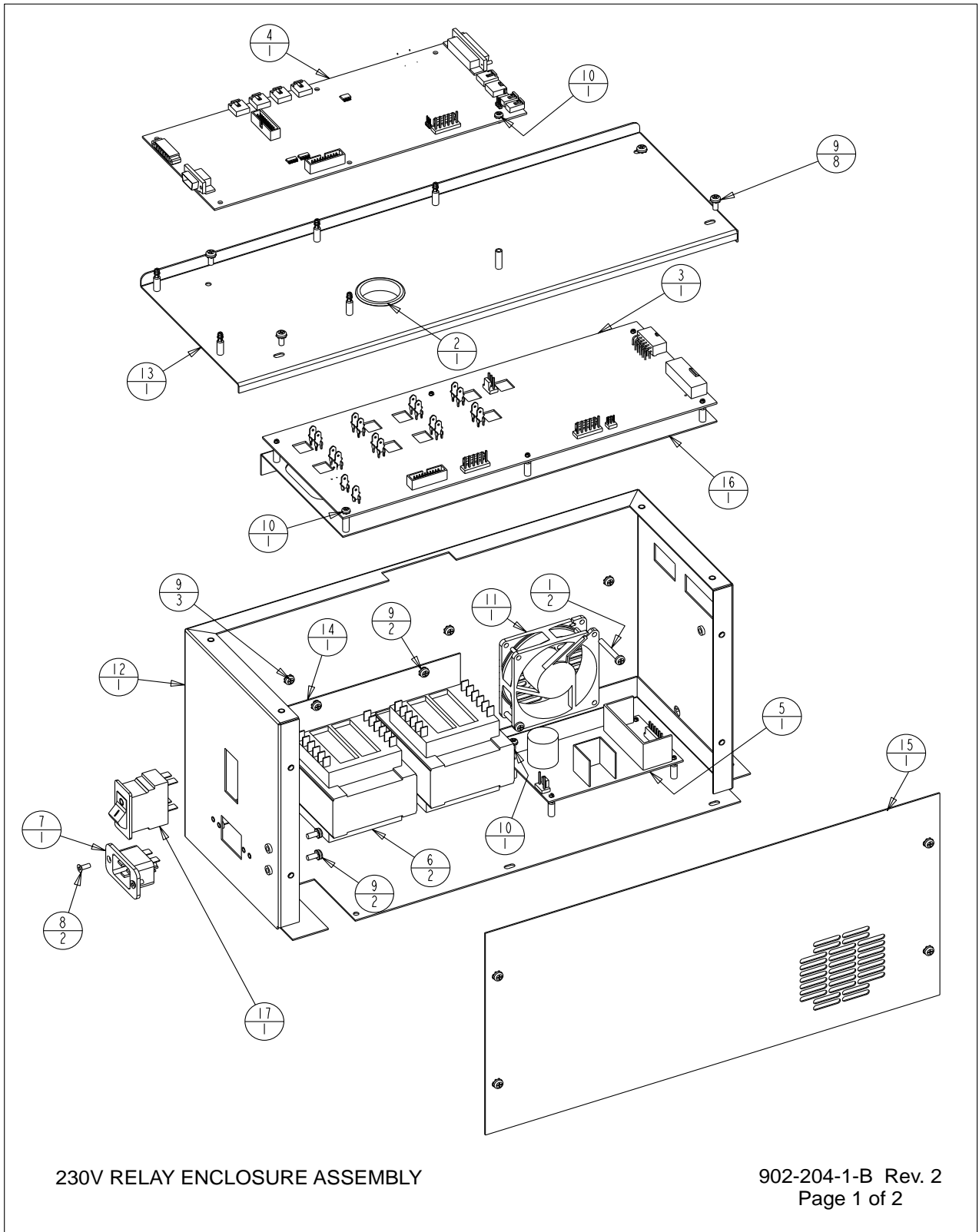
8704-200-2-B Rev. 0  
Page 2 of 2



**Section 8**  
Spare Parts

			BILL OF MATERIALS		
ITEM NO.	PART NO.	PART DESCRIPTION			
1	23002	#8-32 ZP LKWASH HEX NUT			
2	23011	1/4-20 ZP LKWASH HEX NUT			
3	23013	3/8-16 ZP LKWASH HEX NUT			
4	24016	#6 X 1/2" SS PHP SCREW AB POINT			
5	24032	#8-32 X 3/8 SS PHP SCREW F POINT			
6	24038	1/4-20 X 1/2 SELF TAPPING SCREW			
7	24042	#8-32 X 1/2 SS PHP SCREW F POINT			
8	24049	1/4 ZP FLAT WASHER			
9	25040	#6 U SPEED NUT STL. STL.			
10	30016	1" SNAP BUSHING			
11	114033	COMPRESSOR MOUNTING FOOT			
12	114034	COMPRESSOR MOUNTING SLEEVE			
13	115032	BLACK ABS PLASTIC PULL			
14	116115	FRONT PANEL HINGE			
15	120011	DUAL WHEEL CASTER			
16	121071	LATCH CATCH, PART OF 121071 ASSEMBLY			
17	121071	LATCH KEEPER, PART OF 121071 ASSEMBLY			
18	140452	CONTROL PANEL ASSEMBLY			
19	180306	THERMO BACK-UP SYSTEM BLANK PANEL "SID BLUE"			
20	180308	CONTROL CENTER RECORDER BLANK "SID BLU"			
21	180311	THERMO SIDE CAR RECORDER BEZEL			
22	180327	THERMO CHEST CONTROL CENTER BEZEL			
23	191385	FILTER HOLD DOWN ROD			
24	191953	FREEZER DISPLAY BOARD			
25	195768	BATTERY MOUNT TOP			
26	195782	CHEST FREEZER FAN SHROUD			
BILL OF MATERIALS			27	195783	CHEST FREEZER CONTROL PANEL MOUNTING ANGLE
ITEM NO.	PART NO.	PART DESCRIPTION	28	195791	CHEST FREEZER FRONT PANEL ASSEMBLY
33	195949	CHEST FREEZER SIDE CAR DIVIDER	29	195806	CHEST FREEZER REAR ACCESS PANEL
34	200126	2" RIGID HANGER	30	195807	CHEST FREEZER SIDE CAR SIDE COVER
35	203056	L/S COMPRESSOR 120V	31	195808	CHEST FREEZER SIDE CAR REAR PANEL
36	204010	CONDENSOR W/DESUPERHEATER	32	195931	3.0 & 6.7 CU. FT BATTERY SWITCH BRACKET
37	207008	PRESSURE SWITCH			
38	207010	PRESSURE SWITCH			
39	209020	LIQUID LINE FILTER DRYER WITH ACCESS PORT			
40	214023	OIL SEPARATOR			
41	290178	CONDENSER PROBE			
42	330039	2-1/2" SNAP BUSHING			
43	360248	SWITCH, MINI SNAP IN POWER			
44	400159	LEAD-ACID BATT. 12V 7AH			
45	550043	1/4-20 X 1" L ZP CARRIAGE BOLT			
46	590020	SCREW, # 8-32X3/8,SS PHP			
47	590027	SCREW, # 6-32X1/4 SS PHP			
48	590029	#8-32 X 3/8 SS PHP EXT SEMS SCREW W/PATCH			
49	610009	1/4-20 S.S. WING NUT			
50	610078	1/4-20 NUT RETAINER (.025-.063 PANEL)			
51	680008	1/4-20 X 1-3/4 SELF TAPPING SCREW			
52	760212	12, 17 AND 20 CU. FT. CHEST AIR FILTER			
53	900113	10" TUBEAXIAL FAN, 115V			
54	120230-02-1	CHEST FREEZER START COMPONENT ENCLOSURE ASSEMBLY	12. 7 CU. FT. CHEST FREEZER SIDE CAR ( F-TS )		

8704-200-4 Rev.0  
Page 2 of 2



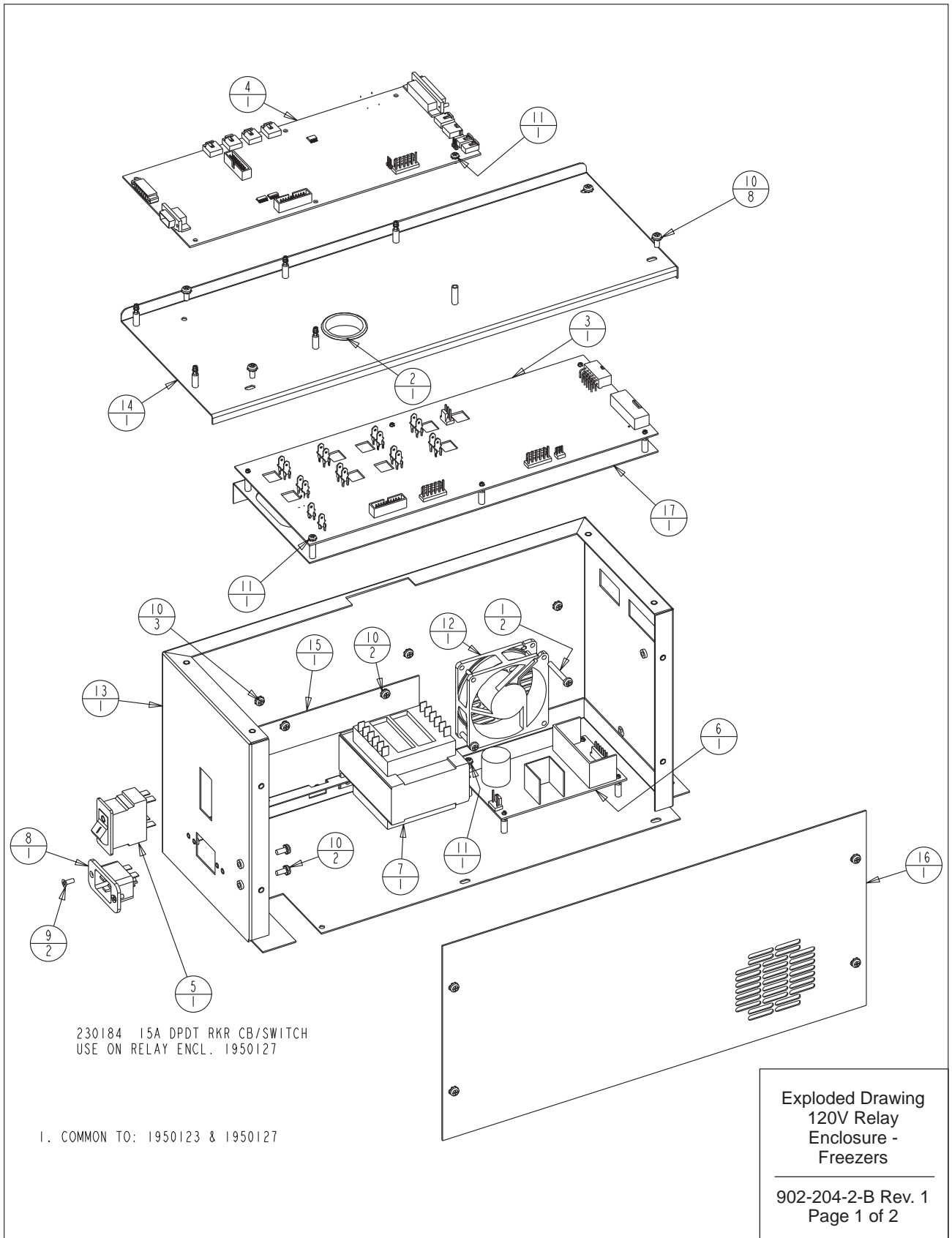
**Section 8**  
Spare Parts

BILL OF MATERIALS		
ITEM NO.	PART NO.	PART DESCRIPTION
1	22143	#8-32 x 1-1/4 SS PHP SCREW
2	30077	1-1/2" SNAP BUSHING
3	191923	HIGH VOLTAGE BOARD 230V
4	191989	MICRO BOARD ( HIGH END)
5	400165	SWITCHER BOARD
6	420090	175V TRANSFORMER
7	460169	POWER INLET, 16/20A
8	490009	#6-32 X 3/8 SS FHP UC SCREW
9	590020	#8-32 X 3/8 SS PHP EXT SEMS SCREW
10	590027	#6-32 X 1/4 SS PHP EXT SEMS SCREW
11	900134	TUBEAXIAL FAN, 30 CFM, 12V
12	195631-16-1	RELAY ENCLOSURE SPOTWELD SUB-ASSEMBLY
13	195631-16-4	RELAY ENCLOSURE COVER/191656 SUPPORT
14	195631-31-3	TRANSFORMER HOLD DOWN
15	195631-31-5	RELAY ENCLOSURE COVER (MAIN)
16	195730-16-1	191658 SUPPORT BRACKET SUB-ASSEMBLY
17	230184	15A DPDT SWITCH/CIRCUIT BKR

1. COMMON TO: 1950124 & 1950128

230V RELAY ENCLOSURE ASSEMBLY

902-204-1-B Rev. 2  
Page 2 of 2



**Section 8**  
Spare Parts

REV	ECN NO.	DATE	BY	CAD	APPD	DESCRIPTION OF REVISION
0	FR-2202	06-23-11	KDG	KDG	DRP	RELEASED FOR PRODUCTION / REL. 6
1	FR-2409	10-10-12	AJC	KDG	CCS	REMOVED 1950121 & 1950125 LOW END BOXES

BILL OF MATERIALS		
ITEM NO.	PART NO.	PART DESCRIPTION
1	22143	#8-32 x 1-1/4 SS PHP SCREW
2	30077	1-1/2" SNAP BUSHING
3	191932	HIGH VOLTAGE BOARD 120V
4	191989	MICRO BOARD ( HIGH END)
5	230183	20A DPDT SWITCH/CIRCUIT BKR
6	400165	SWITCHER BOARD
7	420065	175V TRANSFORMER
8	460169	POWER INLET, 16/20A
9	490009	#6-32 X 3/8 SS FHP UC SCREW
10	590020	#8-32 X 3/8 SS PHP EXT SEMS SCREW
11	590027	#6-32 X 1/4 SS PHP EXT SEMS SCREW
12	900134	TUBEAXIAL FAN, 30 CFM, 12V
13	195631-16-1	RELAY ENCLOSURE SPOTWELD SUB-ASSEMBLY
14	195631-16-4	RELAY ENCLOSURE COVER/191656 SUPPORT
15	195631-31-3	TRANSFORMER HOLD DOWN
16	195631-31-5	RELAY ENCLOSURE COVER (MAIN)
17	195730-16-1	191658 SUPPORT BRACKET SUB-ASSEMBLY

THIS DOCUMENT CONTAINS PROPRIETARY INFORMATION AND SUCH INFORMATION IS NOT TO BE DISCLOSED TO OTHERS FOR ANY PURPOSE NOR USED FOR MANUFACTURING PURPOSE WITHOUT WRITTEN PERMISSION FROM THERMO FISHER SCIENTIFIC

**ThermoFisher**  
**SCIENTIFIC**

BOX 649, MARIETTA, OHIO 45750

MODEL/PART NAME: RELAY ENCLOSURE ASSEMBLY

DWG TITLE: 120 VOLT RELAY ENCLOSURE ASSY

DWN: KDG    CAD: KDG    APPD: DRP    DATE: 06-23-11    SCALE: 0.250

MATERIAL: -

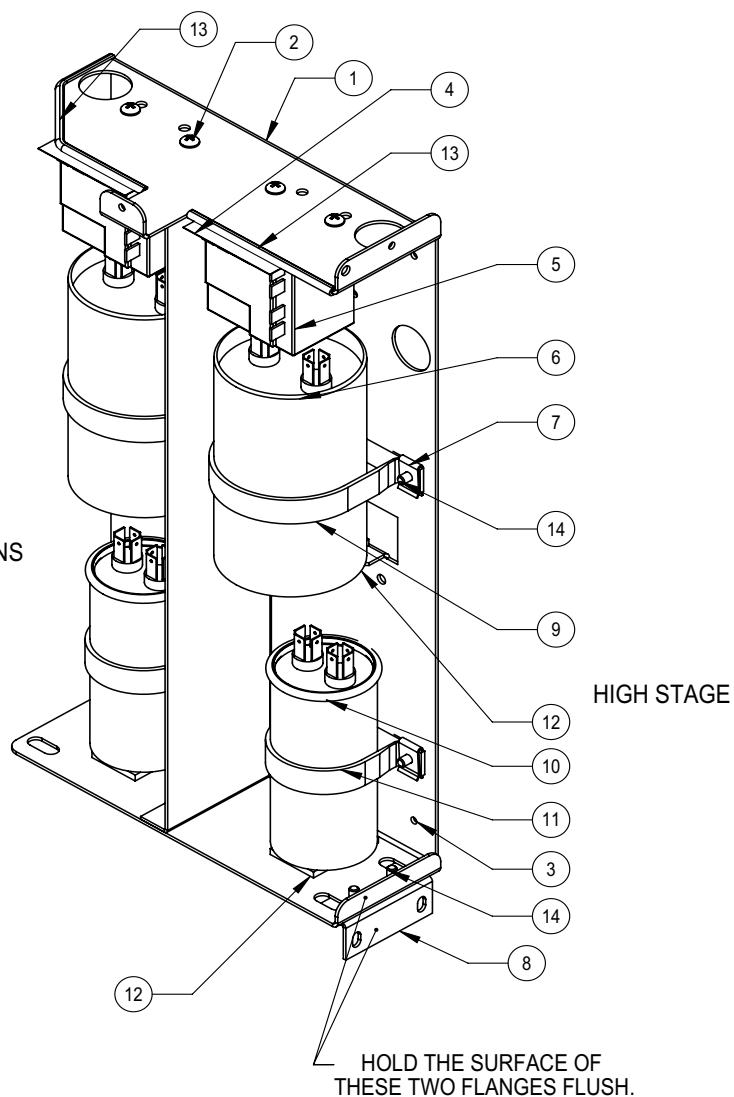
PAINT: N/A

TOLERANCE UNLESS OTHERWISE SPECIFIED	DRAWING NUMBER	SIZE
ANGLES:                    DECIMAL: .XX=± .xxx=±	902-204-2	B

Exploded Drawing  
120V Relay  
Enclosure -  
Freezers

902-204-2-B Rev. 1  
Page 2 of 2

LOW STAGE  
USE THIS SIDE FOR  
-40C CONFIGURATIONS



NOTES:

1. SEE PSS 8602-723-012 FOR ASSEMBLY WIRING AND OTHER DETAILS.
2. AFTER ATTACHING NOMEX COVER (250138) WITH SCREWS (590020), STICK ESD LABELS (220555) TO OUTSIDE OF COVER.
3. IDENTIFY EACH ASSEMBLY WITH LABELS ON THE BOTTOM AND BACK THAT INCLUDE THE FOLLOWING:  
 FIRST LINE - ASSEMBLY NUMBER AND REVISION  
 SECOND LINE - BAR CODE OF ASSEMBLY AND REVISION  
 THIRD LINE - UNIQUE SERIAL NUMBER INCLUDING DATE OF MANUFACTURE IN THE FOLLOWING FORMAT AND ORDER: THREE LETTER MANUFACTURING SITE, TWO DIGIT YEAR MANUFACTURED, TWO DIGIT WEEK MANUFACTURED FOLLOWED BY A UNIQUE FOUR DIGIT NUMBER.  
 FOURTH LINE - BAR CODE OF UNIQUE SERIAL NUMBER.  
 FIFTH LINE - ASSEMBLY DESCRIPTION IN THE FOLLOWING FORMAT: CHEST, TEMPERATURE, VOLTAGE AND FREQUENCY.

120230-01-1-B Rev. 8  
Page 1 of 2

Chest Freezer Start Component  
Enclosure Assembly



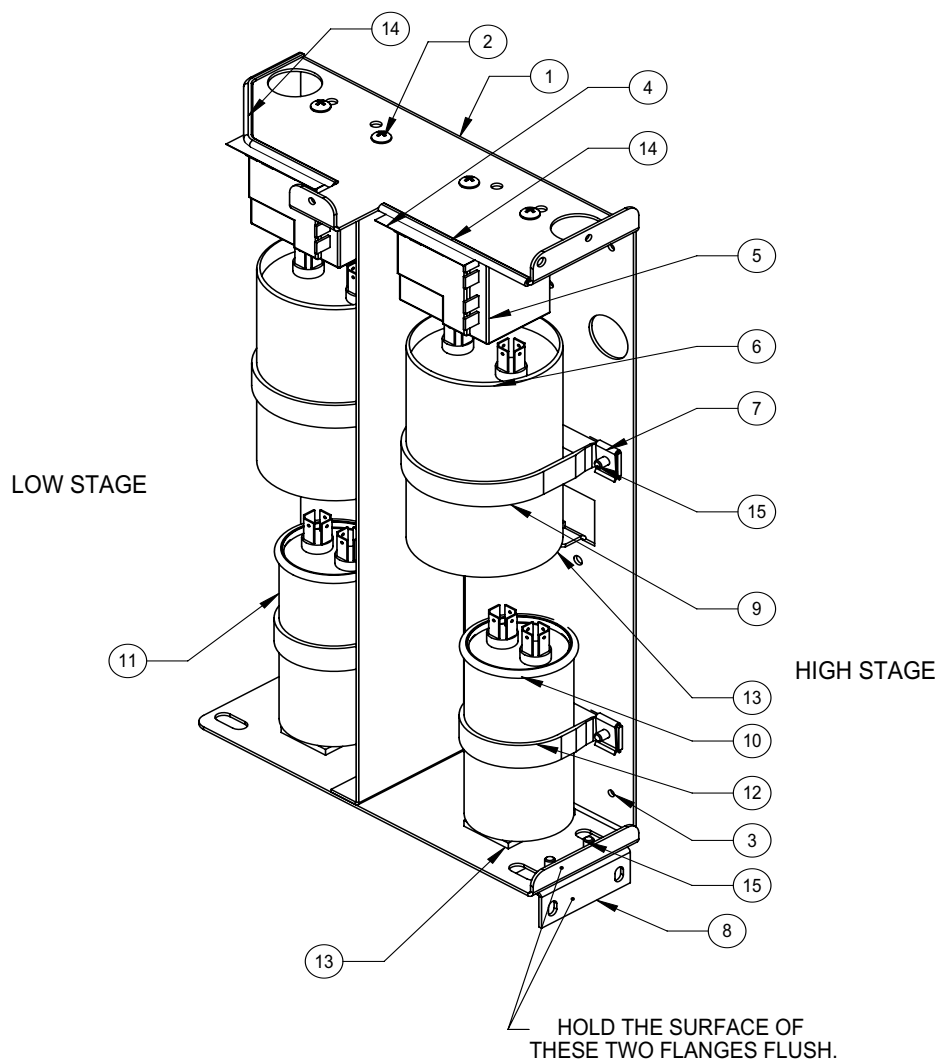
**Section 8**  
Spare Parts

CHEST FREEZER START COMPONENT BRACKET ASSEMBLIES									
ITEM NO.	DESCRIPTION	1915230 -86C 230V 50 Hz	1916230-86C 208/230V 60Hz	1916120 -86C 120V 60 Hz	1985230 -40C 230V 50 Hz	1986230 -40C 208/230V 60 Hz	1986120 -40C 120V 60 Hz	1987120 -40C 3CFT 120V 60 Hz	1917120 -86C 3CFT 120V 60 Hz
1	COMPONENT BRACKET	120230	120230	120230	120230	120230	120230	120230	120230
2	#8 SS PHP SCREW	22051 (4)	22051 (4)	22049 (4)	22051 (2)	22051 (2)	22049 (2)	22049 (2)	22049 (4)
3	8-32 X 3/8 SCREW	590020 (2)	590020 (2)	590020 (2)	590020 (2)	590020 (2)	590020 (2)	590020 (2)	590020 (2)
4	NOMEX INSULATOR	270172 (2)	270172 (2)	270172 (2)	270172 (1)	270172 (1)	270172 (1)	270172 (1)	270172 (2)
5	START RELAY	312288 (2)	312188 (2)	312088 (2)	312288 (1)	312188 (1)	312088 (1)	300460 (1)	300460 (2)
6	START CAPACITOR	170154 (2)	170154 (2)	170154 (2)	170154 (1)	170154 (1)	170154 (1)	170273 (1)	170273 (2)
7	#8 SPEED NUT, S.S.	327675 (4)	327675 (4)	327675 (4)	327675 (2)	327675 (2)	327675 (2)	327675 (2)	327675 (4)
8	HOLD DOWN BRACKET	111047	111047	111047	111047	111047	111047	111047	N/R
9	2.5" VINYL COATED STRAP	600106 (2)	600106 (2)	600106 (2)	600106 (1)	600106 (1)	600106 (1)	600106 (1)	600106 (2)
10	RUN CAPACITOR	170097 (2)	170226 (2)	170224 (2)	170097 (1)	170226 (1)	170224 (1)	170272 (1)	170272 (2)
11	1.75" VINYL COATED STRAP	600107 (2)	600107 (2)	600107 (2)	600107 (1)	600107 (1)	600107 (1)	600107 (1)	600107 (2)
12	NEOPRENE TAPE 1/8" X 1" X 2"	28003 (4)	28003 (4)	28003 (4)	28003 (2)	28003 (2)	28003 (2)	28003 (2)	28003 (4)
13	EDGE GUARD (CUT TO LENGTH)	114012	114012	114012	114012	114012	114012	114012	114012
14	#8 X 1/2 PHP TYPE AB	24021 (6)	24021 (6)	24021 (6)	24021 (4)	24021 (4)	24021 (4)	24021 (6)	24021 (3)
NOT SHOWN *	15 ULT MAIN HARNESS (REFERENCE ONLY)	350082	350082	350082	350109	350109	350109	350228	350229
NOT SHOWN	16 ENCLOSURE LOW STAGE HARNESS	350108	350108	350108	350108	350108	350108	350108	350108
NOT SHOWN	17 ENCLOSURE HIGH STAGE HARNESS	350107	350107	350107	N/A	N/A	N/A	N/A	350107
NOT SHOWN	18 NOMEX COVER	250138	250138	250138	250138	250138	250138	250138	250138
NOT SHOWN	19 ESD CAUTION LABEL	220555 (2)	220555 (2)	220555 (2)	220555 (2)	220555 (2)	220555 (2)	220555 (2)	220555 (2)
NOT SHOWN, SEE NOTE 3	20 IDENTIFICATION LABEL	723050	723060	712060	123050	123060	112060	225015	225016

\* THE ULT MAIN HARNESS IS LISTED FOR INFORMATION ONLY. IT IS NOT PART OF THIS ASSEMBLY.

120230-01-1-B Rev. 8  
Page 2 of 2

Chest Freezer Start Component  
Enclosure Assembly



**NOTES:**

1. SEE PSS 8602-723-012 FOR ASSEMBLY WIRING AND OTHER DETAILS.
2. AFTER ATTACHING NOMEX COVER (250138) WITH SCREWS (590020), STICK ESD LABELS (220555) TO OUTSIDE OF COVER, APPLY IDENTIFICATION LABEL TO BOTTOM AND BACK OF THE ASSEMBLY.

Chest Freezer Start Component  
Enclosure Assembly

120230-02-1 Rev. 0  
Page No. 1 of 2

**Section 8**  
Spare Parts

CHEST FREEZER START COMPONENT BRACKET ASSEMBLIES - EMBRACO COMPRESSORS					
ITEM NO.	DESCRIPTION	1980235 -86C 230V 50 Hz	1980236 -86C 208/230V 60Hz	1980120 -86C 120V 60 Hz	
1	COMPONENT BRACKET	120230	120230	120230	
2	6-32 X 3/8 SS PHP SCREW	22049 (4)	22049 (4)	22049 (4)	
3	8-32 X 3/8 SS PHP SEM SCREW	590020 (2)	590020 (2)	590020 (2)	
4	NOMEX INSULATOR	270172 (2)	270172 (2)	270172 (2)	
5	START RELAY	312289 (2)	312189 (2)	312089 (2)	
6	START CAPACITOR	623050 (2)	623060 (2)	612060 (2)	
7	#8 SPEED NUT, S.S.	327675 (4)	327675 (4)	327675 (4)	
8	HOLD DOWN BRACKET	111047	111047	111047	
9A	2.5" VINYL COATED STRAP	N/A	N/A	600106 (4)	
9B	2" VINYL COATED STRAP	600108 (2)	600108 (2)	N/A	
10	RUN CAPACITOR (HS)	223050	223060	212060	
11	RUN CAPACITOR (LS)	223050	223050	212060	
12	1.75" VINYL COATED STRAP	600107 (2)	600107 (2)	SEE 9A	
13	NEOPRENE TAPE 1/8" X 1/2"	28001 (4)	28001 (4)	28001 (4)	
14	EDGE GUARD (CUT TO LENGTH)	114012	114012	114012	
15	#8 X 1/2 PHP SCREW TYPE AB	24021 (6)	24021 (6)	24021 (6)	
NOT SHOWN *	16	ULT MAIN HARNESS (REFERENCE ONLY)	350082	350082	350082
NOT SHOWN	17	ENCLOSURE LOW STAGE HARNESS	350108	350108	350108
NOT SHOWN	18	ENCLOSURE HIGH STAGE HARNESS	350107	350107	350107
NOT SHOWN	19	NOMEX COVER	250138	250138	250138
NOT SHOWN	20	ESD CAUTION LABEL	220555 (2)	220555 (2)	220555 (2)
NOT SHOWN	21	IDENTIFICATION LABEL	225019 (2)	225017 (2)	225018 (2)

\* THE ULT MAIN HARNESS IS LISTED FOR INFORMATION ONLY. IT IS NOT PART OF THIS ASSEMBLY.

Chest Freezer Start Component  
Enclosure Assembly

120230-02-1 Rev. 0  
Page No. 2 of 2

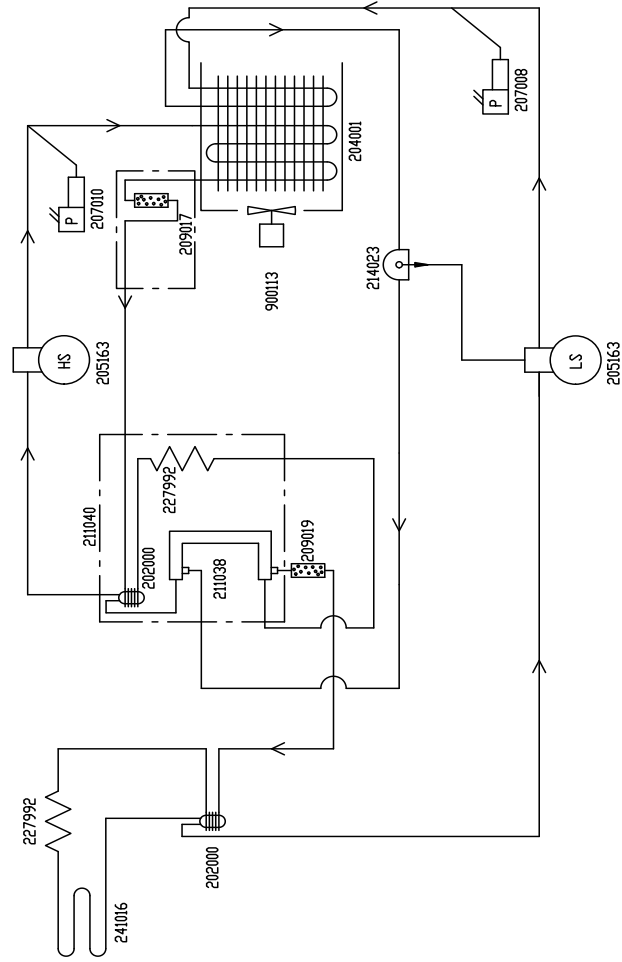
CASCADE REFRIGERATION

HIGH TEMP STAGE

HIGH TEMP. STAGE REFRIGERANT: R-404A 10.4 OZ. (295gm) ± 0.4 OZ. (11.3gm)  
 HIGH TEMPERATURE STAGE OIL: MOBIL EAL ARCTIC 2ECC POLYOL ESTER OIL  
 CAP. TUBE: 10 FT. OF .042 IN. I.D.  
 12 WRAPS, 5.6 FT. DN ACCUMULATOR

LOW TEMP. STAGE REFRIGERANT: R-290 0.2 OZ. (5.7gm) MAX. ; VAC TO 20"  
 R-508B 5.9 OZ. (167gm) ± 0.5 OZ. (14gm)  
 DR 20" TO 102 PSIG ± 9 PSIG

LOW TEMPERATURE STAGE OIL: MOBIL EAL ARCTIC 2ECC POLYOL ESTER OIL  
 OIL SEPARATOR: 15 OZ. (444ml)  
 CAP. TUBE: 14 FT. OF .042 IN. I.D.  
 12 WRAPS, 5.6 FT. DN ACCUMULATOR



\* ALL PSIG MEASUREMENTS WHEN SYSTEM IS AT 23°C

REFRIGERATION SCHEMATIC
MODEL:
3CF -86°C
CHEST FREEZERS, 120V
9999175
8700-90-0-B REV.5

1. COMMON TD: 803CA, CARC0386A, HFC390TA, I903CA, TSC390A, ULT390-10-A  
 VMRC0386A 3 CUFT. FREEZERS (120 V)

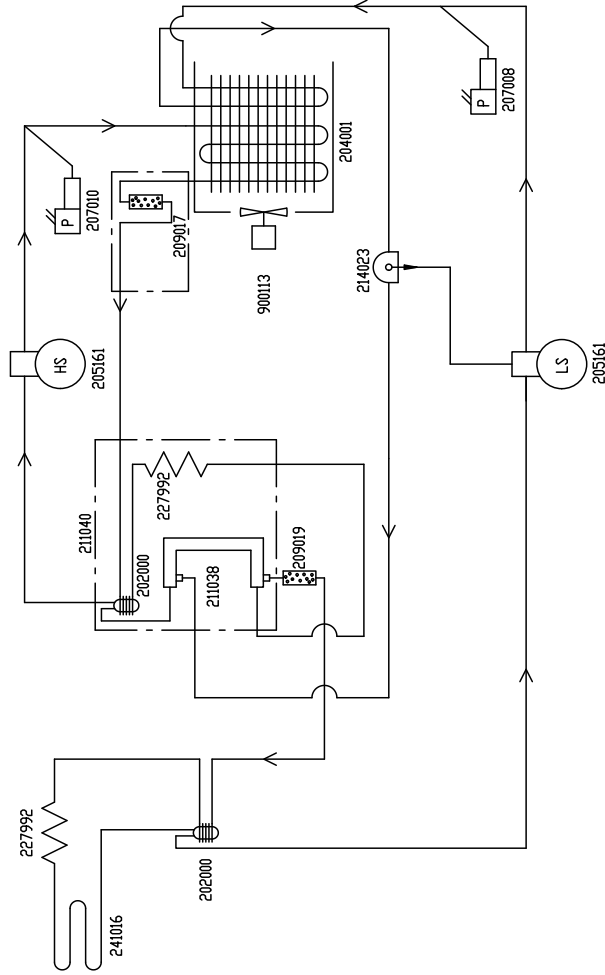
CASCADE REFRIGERATION

HIGH TEMP. STAGE

HIGH TEMP. STAGE REFRIGERANT: R-404A 82 OZ. (232gm) ± 0.4 OZ. (11.3gm)  
 HIGH TEMPERATURE STAGE OIL: MOBIL EAL ARCTIC 22CC POLYOL ESTER OIL  
 CAP. TUBE: 20 FT. OF .042 IN. I.D.  
 12 WRAPS, 5.6 FT. DN ACCUMULATOR

LOW TEMP. STAGE REFRIGERANT: R-290 0.23 OZ. (6.5gm) MAX. J VAC TO 20"  
 R-508B 6.6 OZ. (188gm) ± 0.5 OZ. (14gm)  
 OR 20" TO 102 PSIG ± 9 PSIG

LOW TEMPERATURE STAGE OIL: MOBIL EAL ARCTIC 22CC POLYOL ESTER OIL  
 OIL SEPARATOR: 15 OZ. (444ml)  
 CAP. TUBE: 20 FT. OF .042 IN. I.D.  
 12 WRAPS, 5.6 FT. DN ACCUMULATOR



\* ALL PSIG MEASUREMENTS WHEN SYSTEM IS AT 23°C

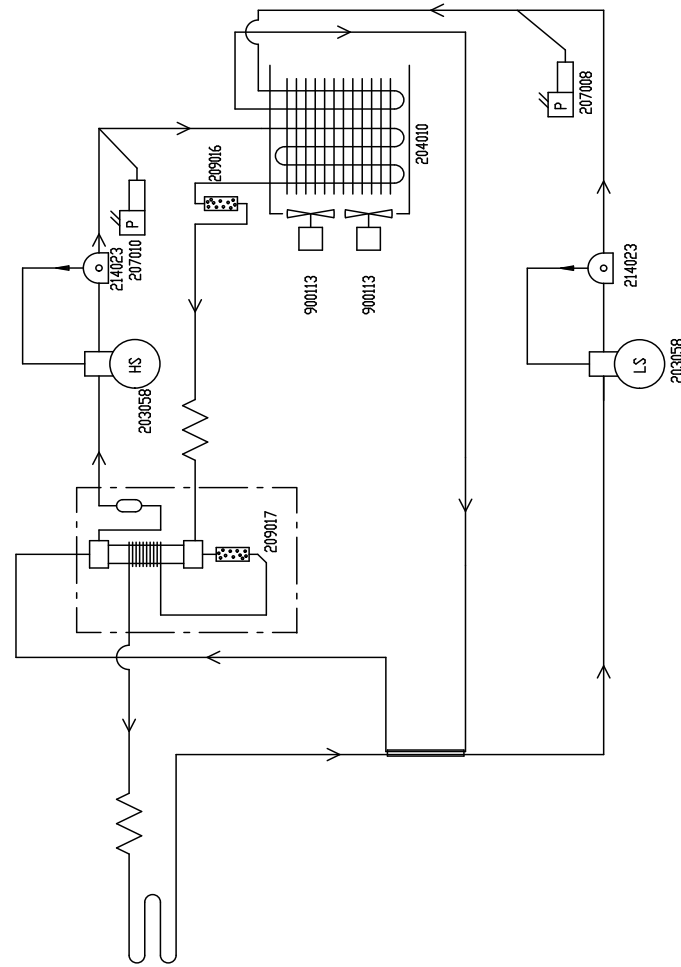
LOW TEMP. STAGE

REFRIGERATION SCHEMATIC
MODEL:
3CF -86°C
CHEST FREEZERS, 230V
9999176
8701-90-0-B REV.4

1. COMMON TD: 803CV, HFC390TV, 1903CV, TSC390V, ULT390-10-V, VMRC0386V 3 CUFT. FREEZERS (230 V)

CASCADE REFRIGERATION

HIGH TEMP STAGE

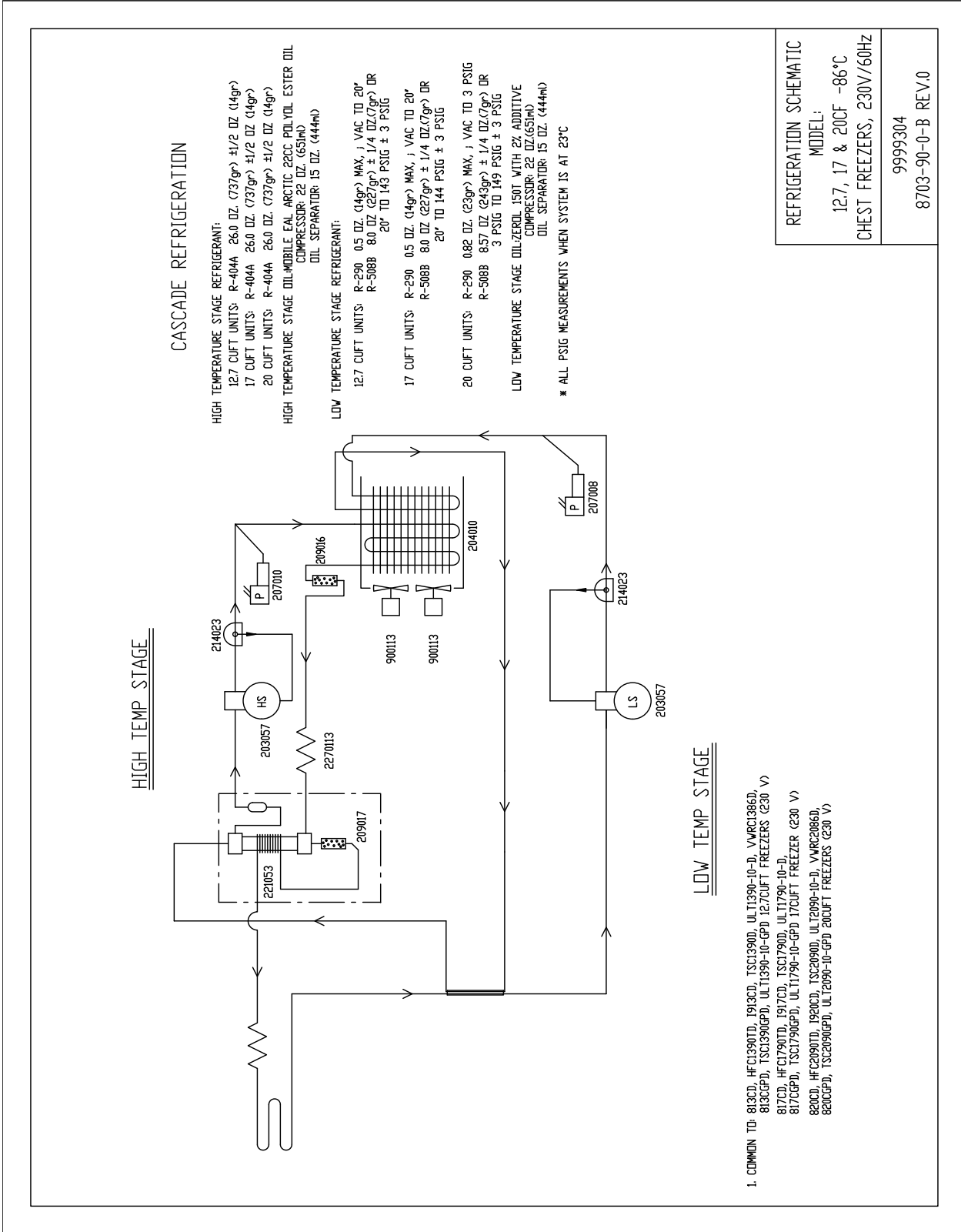


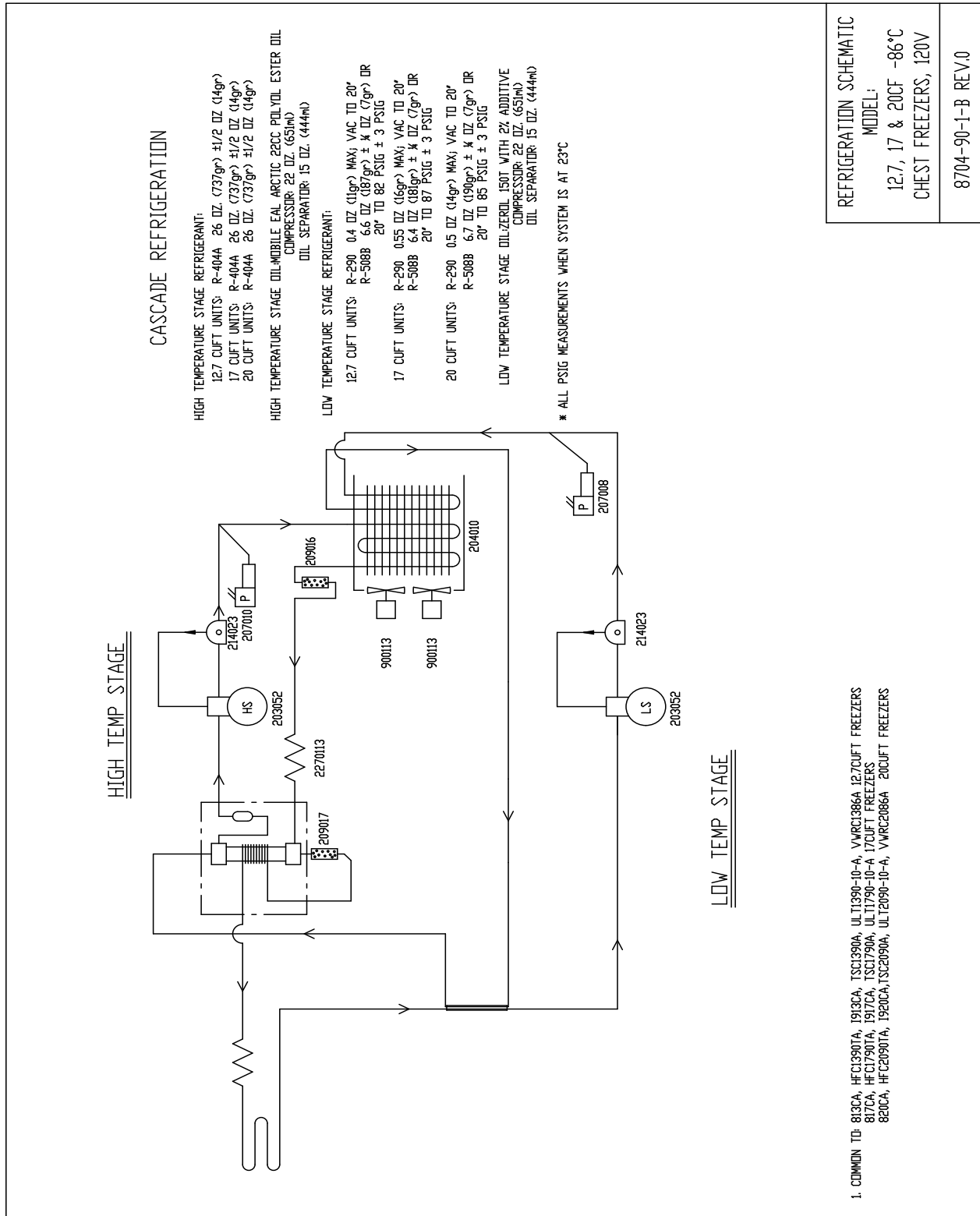
LOW TEMP STAGE

- HIGH TEMPERATURE STAGE REFRIGERANT:**  
 12.7 CUFT UNITS: R-404A 26 OZ (737gr) ±1/2 OZ (14gr)  
 17 CUFT UNITS: R-404A 26 OZ (737gr) ±1/2 OZ (14gr)  
 20 CUFT UNITS: R-404A 26 OZ (737gr) ±1/2 OZ (14gr)
- HIGH TEMPERATURE STAGE OIL-MOBILE EAL ARCTIC 22CC POLYOL ESTER OIL:**  
 COMPRESSOR: 22 OZ (651ml)  
 OIL SEPARATOR: 15 OZ (444ml)
- LOW TEMPERATURE STAGE REFRIGERANT:**  
 12.7 CUFT UNITS: R-290 0.7 OZ (20gr) MAX; VAC TO 3 PSIG  
 R-508B 7.5 OZ (213gr) ± 1/4 OZ (7gr) DR  
 3 PSIG TO 102 PSIG ± 3 PSIG  
 17 CUFT UNITS: R-290 0.82 OZ (23gr) MAX; VAC TO 3 PSIG  
 R-508B 8.3 OZ (235gr) ± 1/4 OZ (7gr) DR  
 3 PSIG TO 108 PSIG ± 3 PSIG  
 20 CUFT UNITS: R-290 0.82 OZ (23gr) MAX; VAC TO 3 PSIG  
 R-508B 8.57 OZ (243gr) ± 1/4 OZ (7gr) DR  
 3 PSIG TO 112 PSIG ± 3 PSIG
- LOW TEMPERATURE STAGE OIL-ZEROL 150T WITH 2% ADDITIVE:**  
 COMPRESSOR: 22 OZ (651ml)  
 OIL SEPARATOR: 15 OZ (444ml)
- \* ALL PSIG MEASUREMENTS WHEN SYSTEM IS AT 23°C

- COMMON TO: 813CV, HFC1390TV, I913CV, TSCI390V, ULT1390-10-V, VMRC1366V 12.7CUFT FREEZERS  
 817CV, HFC1790TV, I917CV, TSCI790V, ULT1790-10-V 17CUFT FREEZER  
 820CV, HFC2090TV, I920CV, TSC2090V, ULT2090-10-V, VMRC2086V 20CUFT FREEZERS

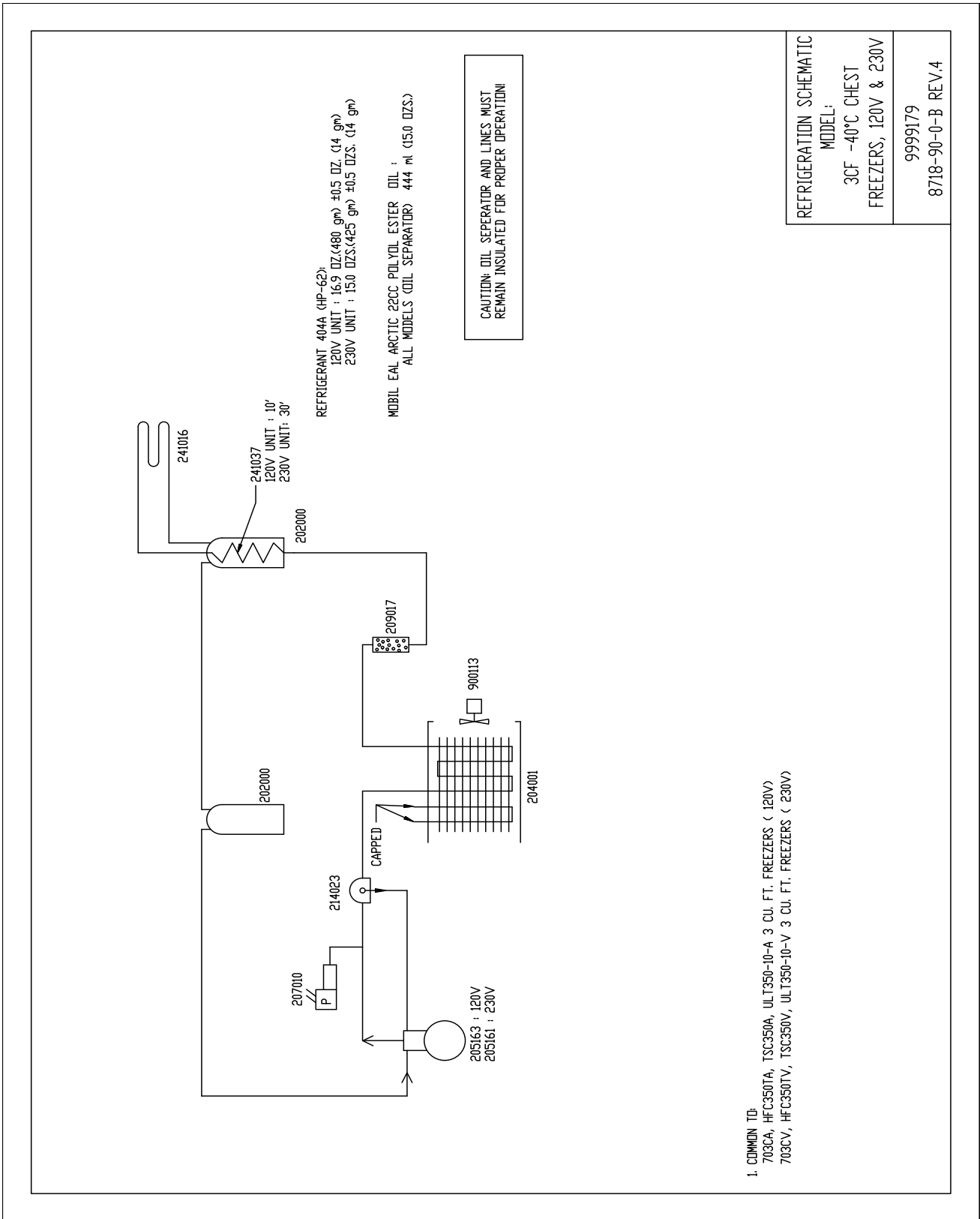
REFRIGERATION SCHEMATIC
MODEL: 12.7, 17 & 20CF -86°C CHEST FREEZERS, 230V/50HZ
8702-90-1-B REV.0







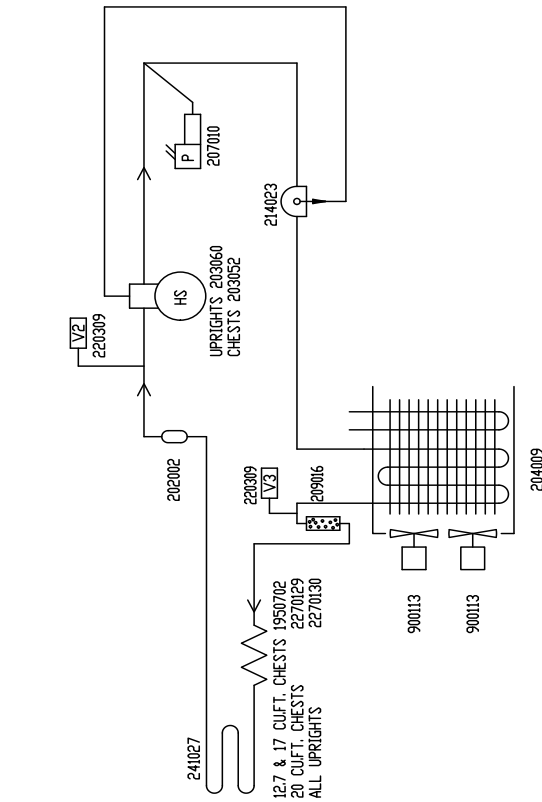
**Section 9**  
Refrigeration Schematics



HIGH TEMP STAGE

REFRIGERATION

HIGH TEMPERATURE STAGE REFRIGERANT:  
 UPRIGHTS  
 13.0 CUFT. UNITS: R-404A 18.5 OZ. (525gr) ±1/2 OZ (14gr)  
 17.0 CUFT. UNITS: R-404A 22 OZ. (624gr) ±1/2 OZ (14gr)  
 23.0 CUFT. UNITS: R-404A 22 OZ. (624gr) ±1/2 OZ (14gr)  
 HIGH TEMPERATURE STAGE OIL:MOBILE EAL ARCTIC 22CC POLYOL ESTER OIL  
 COMPRESSOR: 40 OZ.(1183ml)  
 OIL SEPARATOR: 15 OZ.(444ml)  
 CHESTS  
 12.7 CUFT. UNITS: R-404A 19 OZ. (538gr) ±1/2 OZ (14gr)  
 17.0 CUFT. UNITS: R-404A 21 OZ. (595gr) ±1/2 OZ (14gr)  
 20.0 CUFT. UNITS: R-404A 23 OZ. (652gr) ±1/2 OZ (14gr)  
 HIGH TEMPERATURE STAGE OIL:MOBILE EAL ARCTIC 22CC POLYOL ESTER OIL  
 COMPRESSOR: 40 OZ.(1183ml)  
 OIL SEPARATOR: 15 OZ.(444ml)



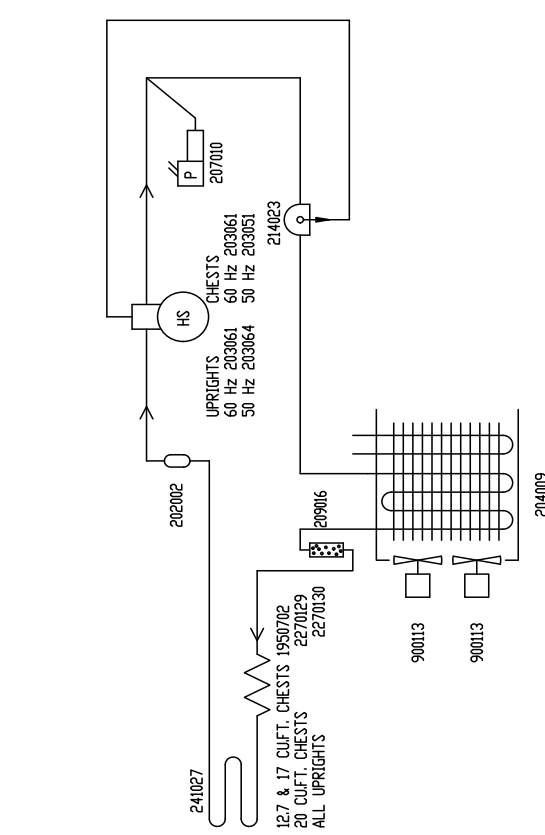
- COMMON TO: 7240A, DXF24140A, HFU40240A, TSD40240A, VWR4040A 13.0 CUFT. UPRIGHT FREEZERS (120 V)  
 7320A, DXF32040A, HFU40320A, TSD40320A, VWR32040A 17.0 CUFT. UPRIGHT FREEZERS (120 V)  
 7400A, DXF40040A, HFU40400A, TSD40400A 23 CUFT. UPRIGHT FREEZER (120 V)  
 713CA, HFC1350TA, TSC1350A, UL11350-10-A 12.7 CUFT. CHEST FREEZER (120V)  
 717CA, HFC1750TA, TSC1750A, UL11750-10-A 17.0 CUFT. CHEST FREEZER (120V)  
 720CA, HFC2050TA, TSC2050A, UL12050-10-A 20 CUFT. CHEST FREEZER (120V)

REFRIGERATION SCHEMATIC MODEL: -40°C ULTRA LOW, 120V TEMPERATURE FREEZERS
9999183 8800-90-0-B REV.11

HIGH TEMP STAGE

REFRIGERATION

HIGH TEMPERATURE STAGE REFRIGERANT:  
 50 AND 60 Hz UPRIGHTS 21 OZ. (595gr) ±1/2 OZ. (14gr)  
 130 CUFT. UNITS: R-404A 22 OZ. (624gr) ±1/2 OZ. (14gr)  
 170 CUFT. UNITS: R-404A 22 OZ. (624gr) ±1/2 OZ. (14gr)  
 230 CUFT. UNITS: R-404A 22 OZ. (624gr) ±1/2 OZ. (14gr)  
 HIGH TEMPERATURE STAGE OIL: MOBILE EAL ARCTIC 22CC POLYOL ESTER OIL  
 COMPRESSOR, 40 OZ.(1183ml)  
 OIL SEPARATOR, 15 OZ.(444 ml)  
 CHESTS  
 12.7 CUFT. UNITS: R-404A 19 OZ. (538gr) ±1/2 OZ. (14gr)  
 17.0 CUFT. UNITS: R-404A 21 OZ. (595gr) ±1/2 OZ. (14gr)  
 20.0 CUFT. UNITS: R-404A 23 OZ. (652gr) ±1/2 OZ. (14gr)  
 HIGH TEMPERATURE STAGE OIL: MOBILE EAL ARCTIC 22CC POLYOL ESTER OIL  
 COMPRESSOR, 40 OZ.(1183ml)  
 OIL SEPARATOR, 15 OZ.(444ml)



1. COMMON TO:  
 7240, DIF24040, FV402400, TS340240, V4024040, FV4024040, 7240P, DIF24040P, TS340240P, V4024040P, 130 CUFT. UPRIGHT FREEZERS (230 V)  
 7280, DIF28040, FV402800, TS340280, V4028040, FV4028040, 7280P, DIF28040P, TS340280P, V4028040P, 170 CUFT. UPRIGHT FREEZERS (230 V)  
 7400, DIF4040, FV404000, TS340400, V404040, FV404040, 7400P, DIF4040P, TS340400P, V404040P, 230 CUFT. UPRIGHT FREEZERS (230 V)  
 7130, FFC150T, TS31500, UL1150-10-V, 7130P, TS31500P, UL1150-10-EPD 12.7 CUFT CHEST FREEZER (230V)  
 7100, FFC150T, TS31500, UL1150-10-V, 7100P, TS31500P, UL1150-10-EPD 17.0 CUFT CHEST FREEZER (230V)  
 7200, FFC200T, TS32000, UL1200-10-V, 7200P, TS32000P, UL1200-10-EPD 20.0 CUFT CHEST FREEZER (230V)

REFRIGERATION SCHEMATIC MODEL: -40°C ULTRA LOW, 230V TEMPERATURE FREEZERS
9999274 8801-90-0-B REV.12

DRAWING NUMBER: 195967-90-1-B

REV	CON. NO.	DATE	BY	DESCRIPTION OF REVISION
12	FR-2673	06-04-14	MAM SAG DRP	CHANGE 21406 OIL SEP. TO 214023
13	FR-2762	06-19-17	T.C. SAG DRP	REG. VALVE WAS P/N 992501, 170 PSIG
14	44483	10-27-17	KMB TFI	NOTE CHANGE - 3 PSIG WAS 20" IN 20 CUFT UNITS (1.20 & 230 VOLTS)
15	EDM-00556	09-26-19	IFI	REMOVED 20209 OIL, V2, V3 & COMPRESSOR 20361 WAS 20350

**CASCADE REFRIGERATION**

**HIGH TEMPERATURE STAGE REFRIGERANT:**

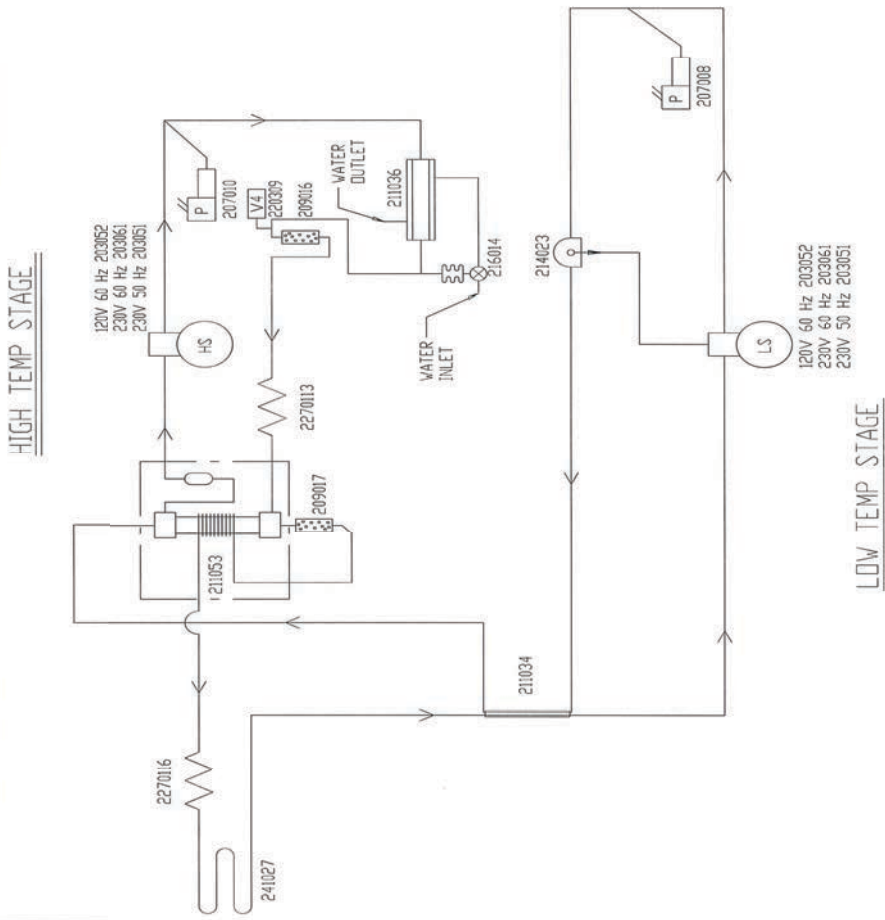
- 12.7 CUFT UNITS: R-404A 18 OZ. (510gr) ±1/2 OZ. (14gr)
- 17 CUFT UNITS: R-404A 18 OZ. (510gr) ±1/2 OZ. (14gr)
- 20 CUFT UNITS: R-404A 18 OZ. (510gr) ±1/2 OZ. (14gr)

**LOW TEMPERATURE STAGE REFRIGERANT:**

- 12.7 CUFT UNITS: R-290 0.5 OZ. (14gr) MAX. ; VAC TO 20" (ALL VOLTAGES) R-508B 15.0 OZ. (425gr) ± 1/4 OZ.(7gr) DR 20" TO 143 PSIG ± 3 PSIG
- 17 CUFT UNITS: R-290 0.5 OZ. (14gr) MAX. ; VAC TO 20" (120 VOLTS) R-508B 15.0 OZ. (425gr) ± 1/4 OZ.(7gr) DR 20" TO 139 PSIG ± 3 PSIG
- 17 CUFT UNITS: R-290 0.5 OZ. (14gr) MAX. ; VAC TO 20" (230 VOLTS) R-508B 15.5 OZ. (439gr) ± 1/4 OZ.(7gr) DR 20" TO 144 PSIG ± 3 PSIG
- 20 CUFT UNITS: R-290 1.0 OZ. (28gr) MAX. ; VAC TO 3 PSIG (120 VOLTS) R-508B 15.0 OZ. (425gr) ± 1/4 OZ.(7gr) DR 3 PSIG TO 139 PSIG ± 3 PSIG
- 20 CUFT UNITS: R-290 1.0 OZ. (28gr) MAX. ; VAC TO 3 PSIG (230 VOLTS) R-508B 16.0 OZ. (454gr) ± 1/4 OZ.(7gr) DR 3 PSIG TO 149 PSIG ± 3 PSIG

LOW TEMPERATURE STAGE OIL:ZEROL 150T WITH 2% ADDITIVE  
COMPRESSOR: 40 OZ.(1183 ml)  
OIL SEPARATOR: 15 OZ. (444ml)

\*\*\*SET WATER REGULATING VALVE FOR 183 PSIG  
\* ALL PSIG MEASUREMENTS WHEN SYSTEM IS AT 23°C

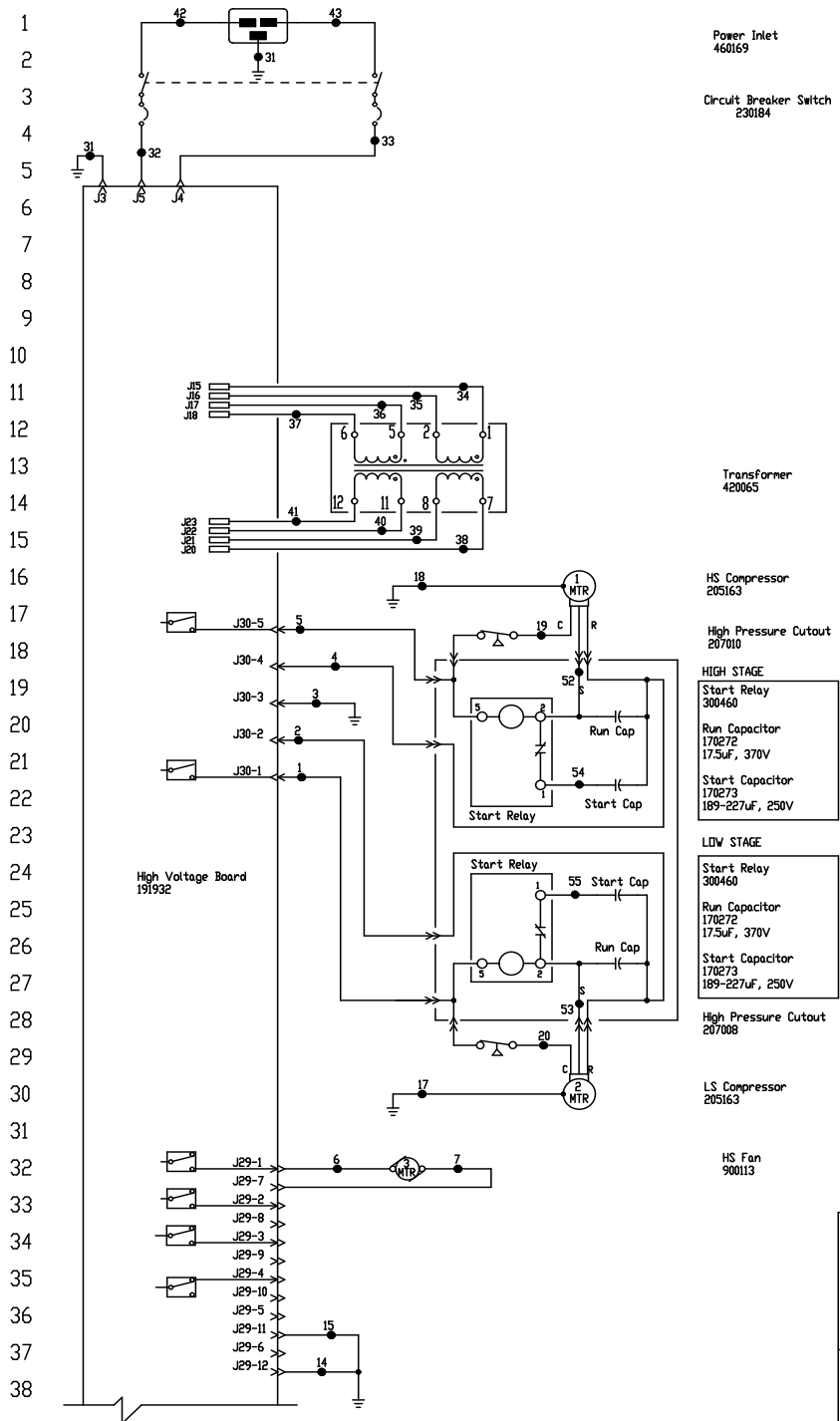


THIS DOCUMENT CONTAINS PROPRIETARY INFORMATION AND SUCH INFORMATION IS NOT TO BE DISCLOSED TO OTHERS FOR ANY PURPOSE NOR USED FOR MANUFACTURING PURPOSES WITHOUT WRITTEN PERMISSION FROM THERMO FISHER SCIENTIFIC		MODEL/PART NAME: -86°C 12.7, 17 & 20 CU FT. CHEST HEI COOLED
DWG TITLE: FREEZER REFRIGERATION SCHEMATIC		
DWG. NO.:	CAD. APPD.:	DATE: 01-24-03
DWG. NO.:	CAD. APPD.:	SCALE: NONE
MATERIAL: N/A		
PAINT COLOR: N/A		
TOLERANCE UNLESS OTHERWISE SPECIFIED:	DRAWING NUMBER	
ANGLES: DECIMAL: XX±	195967-90-1	
	SIZE	
	B	

**ThermoFisher**  
**SCIENTIFIC**  
BD. 649, MARETTA, OHIO 45750

**Section 9**  
Refrigeration Schematics

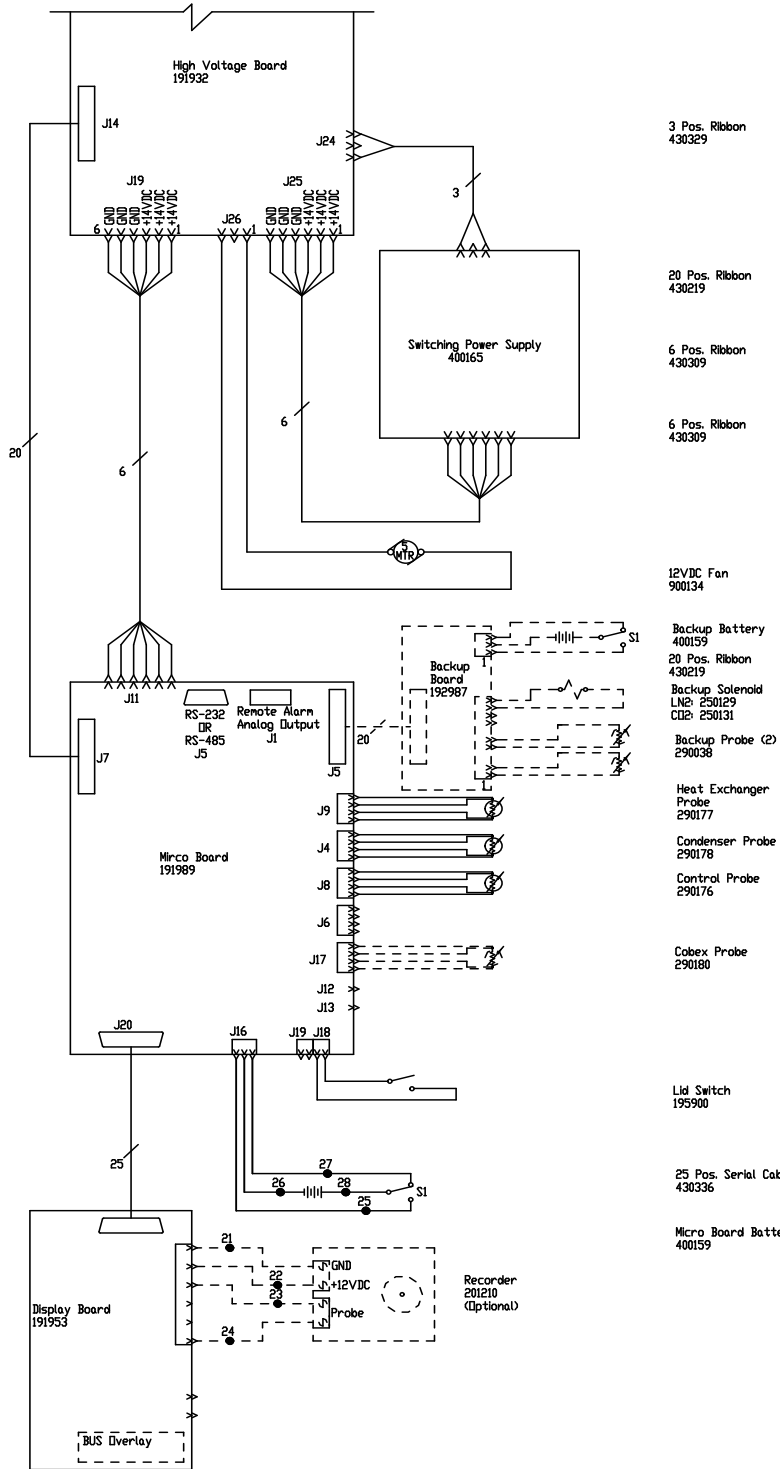
POWER CONNECTION  
 120V, 1Ø, 2W, 60HZ, 11.5 FLA  
 (OPERATING RANGE 108-132V)



ELECTRICAL SCHEMATIC  
 MODEL:  
 3CF -86°C  
 CHEST FREEZER, 120V  
 9999137  
 8700-70-1-D REV.5  
 Page 1 of 3

**Section 10**  
Electrical Schematics

39  
40  
41  
42  
43  
44  
45  
46  
47  
48  
49  
50  
51  
52  
53  
54  
55  
56  
57  
58  
59  
60  
61  
62  
63  
64  
65  
66  
67  
68  
69  
70  
71  
72  
73  
74  
75  
76



**ELECTRICAL SCHEMATIC**  
MODEL:  
3CF -86°C  
CHEST FREEZER, 120V

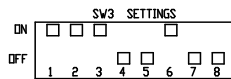
---

9999137  
8700-70-1-D REV.5  
Page 2 of 3

77  
78  
79  
80  
81  
82  
83  
84  
85  
86  
87  
88  
89  
90  
91  
92  
93  
94  
95  
96  
97  
98  
99  
100  
101  
102  
103  
104  
105  
106  
107

WIRE #	COLOR	GAUGE	WIRE #	COLOR	GAUGE
1	BLK	14	25	WHT	18
2	RED	14	26	BLK	18
3	GRN/YEL	14	27	BLK	18
4	RED	14	28	RED	18
5	BLK	14	29		
6	BLK	18	30		
7	BLK	18	31	GRN/YEL	14
8			32	BLK	14
9			33	BLU	14
10			34	BLK	14
11			35	BLU	14
12			36	BLK	14
13			37	BLU	14
14	GRN/YEL	18	38	BLK	14
15	GRN/YEL	18	39	BLU	14
16			40	BLK	14
17	GRN/YEL	14	41	BLU	14
18	GRN/YEL	14	42	BLK	14
19	BLK	14	43	BLU	14
20	BLK	14			
21	BLK	18			
22	RED	18			
23	BLK	18			
24	RED	18			

MODELS:  
3 CUFT. CHEST MODELS (120V) - 803CA, CARC0386A, HFC390TA, 1903CA, TSC390A, ULT390-10-A, VVRC0386A



RS-232 SPECIFICATION

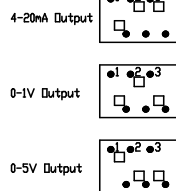
BAUD = 1200  
PARITY = N  
BITS = 8  
STOP BITS = 2

REMOTE CONTACTS/ANALOG OUTPUT	
PIN# 1	Analog Output +
PIN# 2	Analog Output -
PIN# 3	Not Connected
PIN# 4	Not Connected
PIN# 5	Normally Closed
PIN# 6	Common
PIN# 7	Normally Open

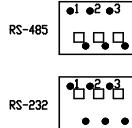
RS-232 PWR	
PIN# 2	TXD
PIN# 3	RXD
PIN# 5	GND

CONTACT RATING: 1A @ 30V  
CONTACTS IN ALARM STATE

SW1 Settings for Analog Output



SW2 Settings for Communication Output



1. Lid switch shown in open position.
2. Battery switch shown in the OFF position.
3. Circuit breaker switch shown in OFF position.
4. Options and accessories shown in dashed lines.

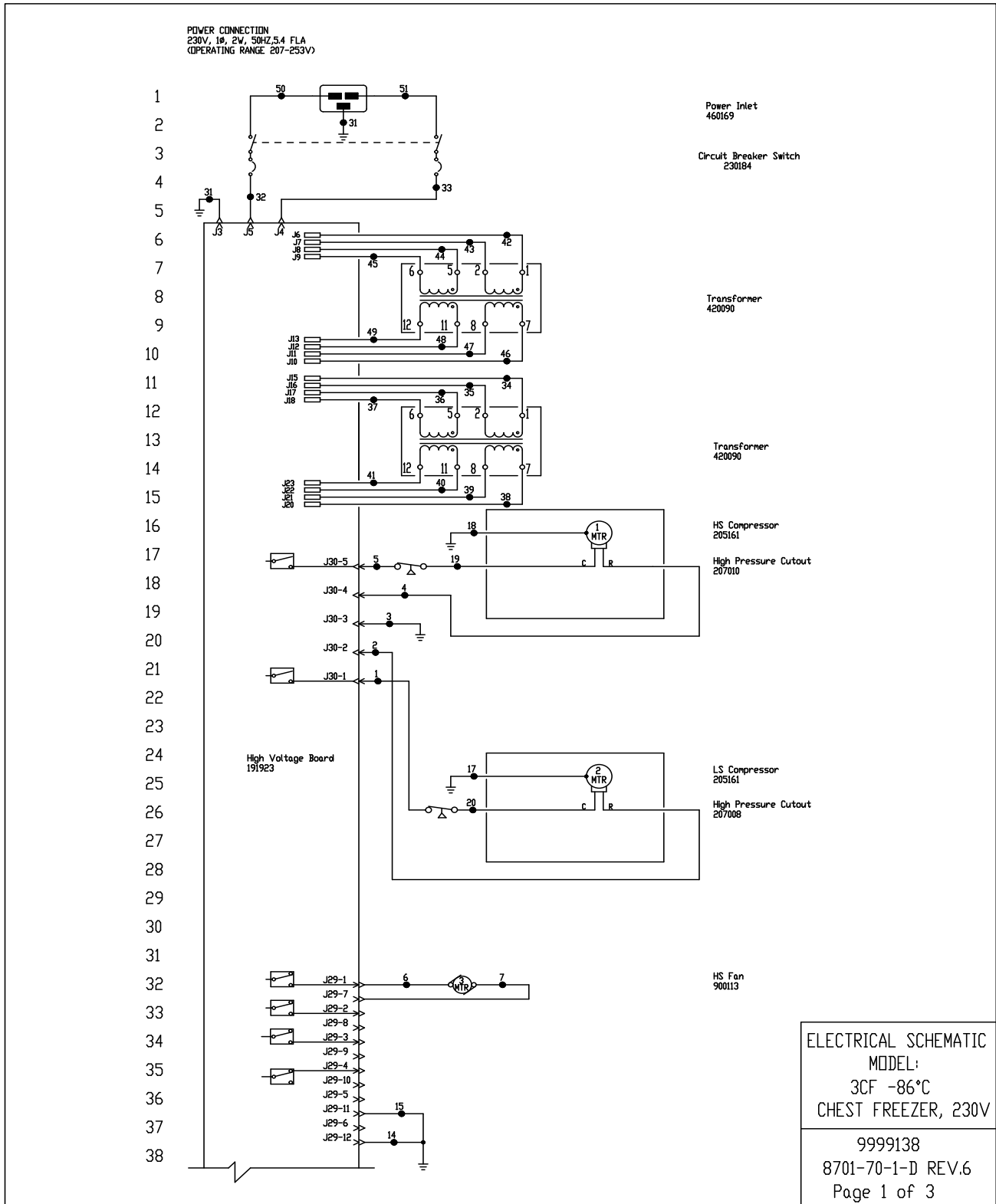
ELECTRICAL SCHEMATIC  
MODEL:  
3CF -86°C  
CHEST FREEZER, 120V

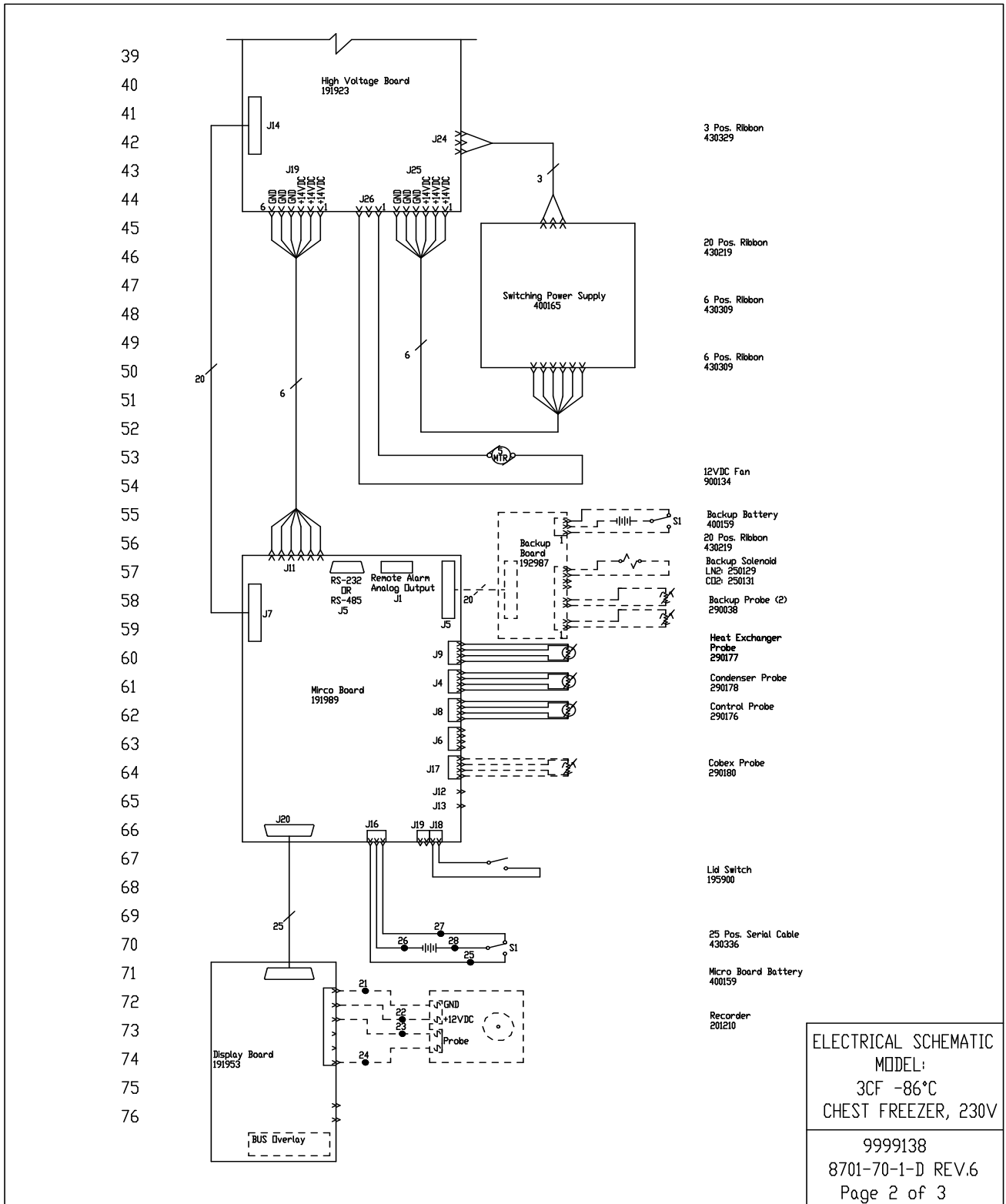
**ATTENTION**  
OBSERVE PRECAUTIONS  
ELECTROSTATIC  
SENSITIVE DEVICES

9999137  
8700-70-1-D REV.5  
Page 3 of 3



**Section 10**  
Electrical Schematics





77

78

79

80

81

82

83

84

85

86

87

88

89

90

91

92

93

94

95

96

97

98

99

100

101

102

103

104

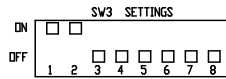
105

106

107

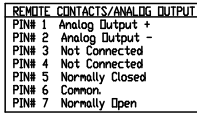
WIRE #	COLOR	GAUGE	WIRE #	COLOR	GAUGE
1	BLK	14	25	WHT	18
2	RED	14	26	BLK	18
3	GRN/YEL	14	27	BLK	18
4	RED	14	28	RED	18
5	BLK	14	29		
6	BLK	18	30		
7	BLK	18	31	GRN/YEL	14
8			32	BLK	14
9			33	BLU	14
10			34	BLK	14
11			35	BLU	14
12			36	BLK	14
13			37	BLU	14
14	GRN/YEL	18	38	BLK	14
15	GRN/YEL	18	39	BLU	14
16			40	BLK	14
17	GRN/YEL	14	41	BLU	14
18	GRN/YEL	14	42	BLK	14
19	BLK	14	43	BLU	14
20	BLK	14	44	BLK	14
21	BLK	18	45	BLU	14
22	RED	18	46	BLK	14
23	BLK	18	47	BLU	14
24	RED	18	48	BLK	14
			49	BLU	14
			50	BLK	14
			51	BLU	14

MODELS:  
3 CU.FT. CHEST MODELS (230V) - 803CV, HFC390TV, I903CV, TSC390V, ULT390-10-V, VVRC0386V



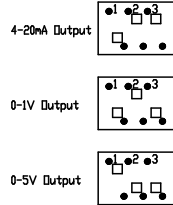
RS-232 SPECIFICATION

BAUD = 1200  
PARITY = N  
BITS = 8  
STOP BITS = 2

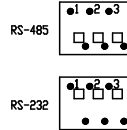


CONTACT RATING: 1A @ 30V  
CONTACTS IN ALARM STATE

SV1 Settings for Analog Output



SV2 Settings for Communication Output



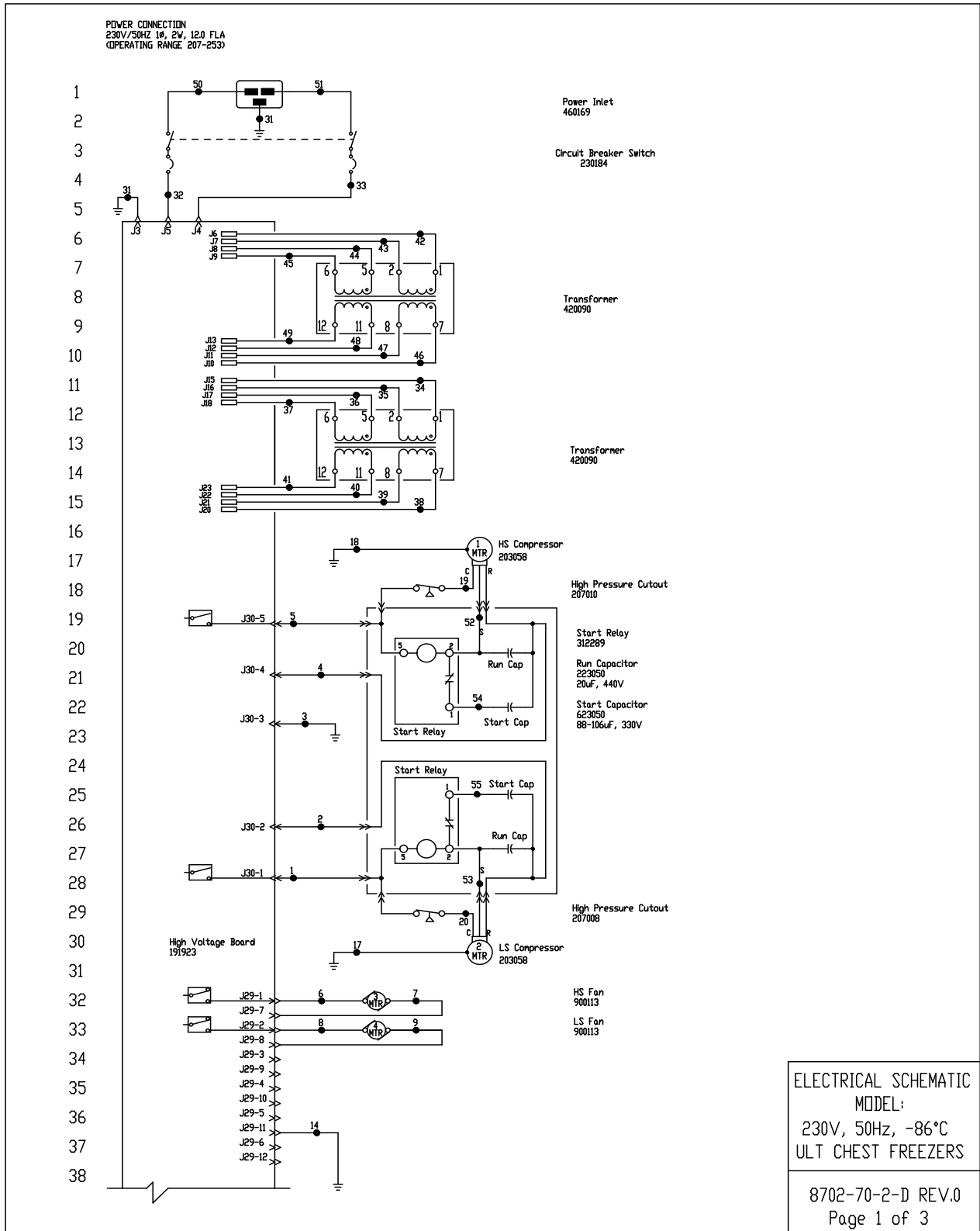
1. Lid switch shown in open position.
2. Battery switch shown in the OFF position.
3. Circuit breaker switch shown in OFF position.
4. Options and accessories shown in dashed lines.

ELECTRICAL SCHEMATIC  
MODEL:  
3CF -86°C  
CHEST FREEZER, 230V

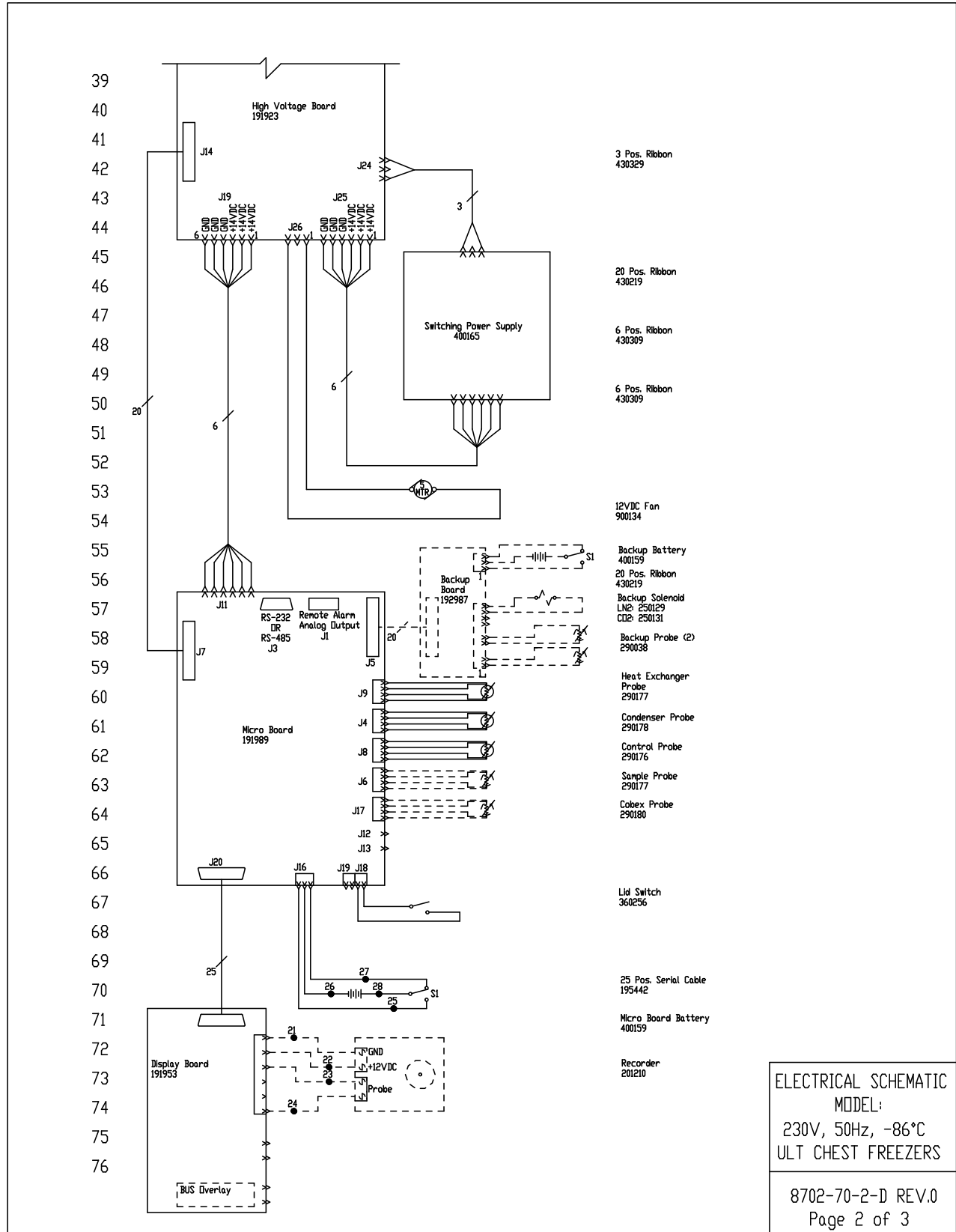


ATTENTION  
OBSERVE PRECAUTIONS  
ELECTROSTATIC  
SENSITIVE DEVICES

9999138  
8701-70-1-D REV.6  
Page 3 of 3



**Section 10**  
Electrical Schematics



77  
78  
79  
80  
81  
82  
83  
84  
85  
86  
87  
88  
89  
90  
91  
92  
93  
94  
95  
96  
97  
98  
99  
100  
101  
102  
103  
104  
105  
106  
107

WIRE #	COLOR	GAUGE	WIRE #	COLOR	GAUGE
1	BLK	14	29	-	-
2	RED	14	30	-	-
3	GRN/YEL	14	31	GRN/YEL	14
4	RED/WHT	14	32	BLK	14
5	BLK/WHT	14	33	BLU	14
6	BLK	18	34	BLK	14
7	BLK	18	35	BLU	14
8	BLK	18	36	BLK	14
9	BLK	18	37	BLU	14
10	BLK	18	38	BLK	14
11	BLK	18	39	BLU	14
14	GRN/YEL	18	40	BLK	14
17	GRN/YEL	14	41	BLU	14
18	GRN/YEL	14	42	BLK	14
19	BLK/WHT	14	43	BLU	14
20	BLK	14	44	BLK	14
21	BLK	18	45	BLU	14
22	RED	18	46	BLK	14
23	BLK	18	47	BLU	14
24	RED	18	48	BLK	14
25	WHT	18	49	BLU	14
26	BLK	18	50	BLK	14
27	BLK	18	51	BLU	14
28	RED	18	52	YEL/WHT	14
			53	YEL	14
			54	BLU/WHT	14
			55	BLU	14

CHEST MODELS:  
12.7 CUFT. (230V) - 813CV, HFC1390TV, 1913CV, TSC1390V, ULT1390-10-V, VVRC1386V  
17 CUFT. (230V) - 817CV, HFC1790TV, 1917CV, TSC1790V, ULT1790-10-V  
20 CUFT. - 820CV, HFC2090TV, 1920CV, TSC2090V, ULT2090-10-V, VVRC2086V

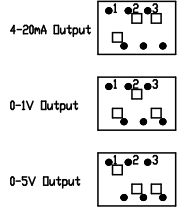
REMOTE CONTACTS/ANALOG OUTPUT  
PIN# 1 Analog Output +  
PIN# 2 Analog Output -  
PIN# 3 Not Connected  
PIN# 4 Not Connected  
PIN# 5 Normally Closed  
PIN# 6 Common  
PIN# 7 Normally Open  
CONTACT RATINGS: 1A @ 30V  
CONTACTS IN ALARM STATE

RS-232 SPECIFICATION

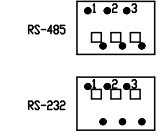
BAUD = 1200  
PARITY = N  
BITS = 8  
STOP BITS = 2

RS-232 PORT  
PIN# 2 TXD  
PIN# 3 RXD  
PIN# 5 GND

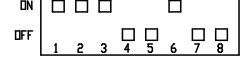
SW1 Settings for Analog Output



SW2 Settings for Communication Output



SW3 SETTINGS



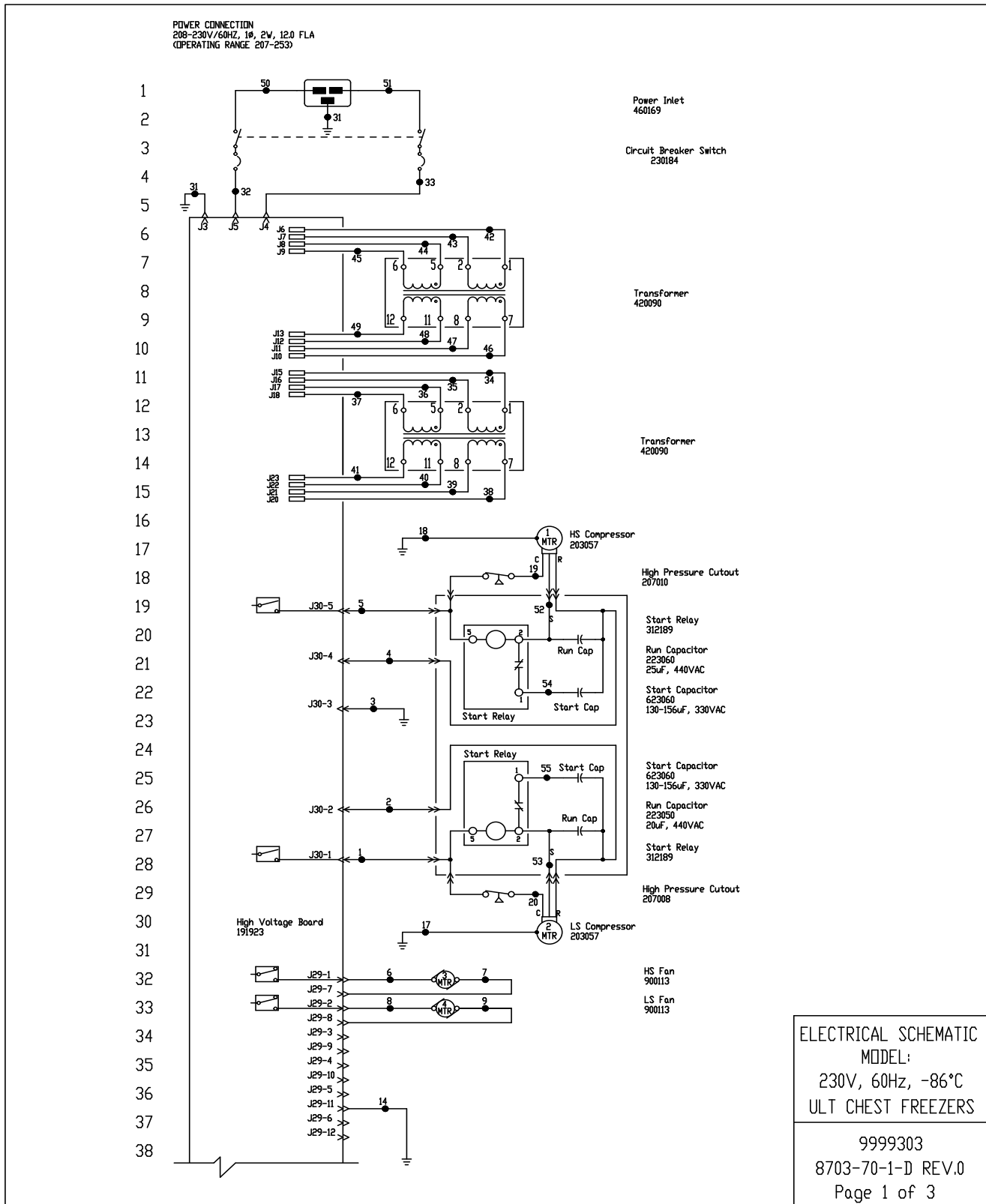
1. Schematic represents chest models.
2. Door switches shown in open position.
3. Battery switch shown in the OFF position.
4. Circuit breaker switch shown in OFF position.
5. Options and accessories shown in dashed lines.

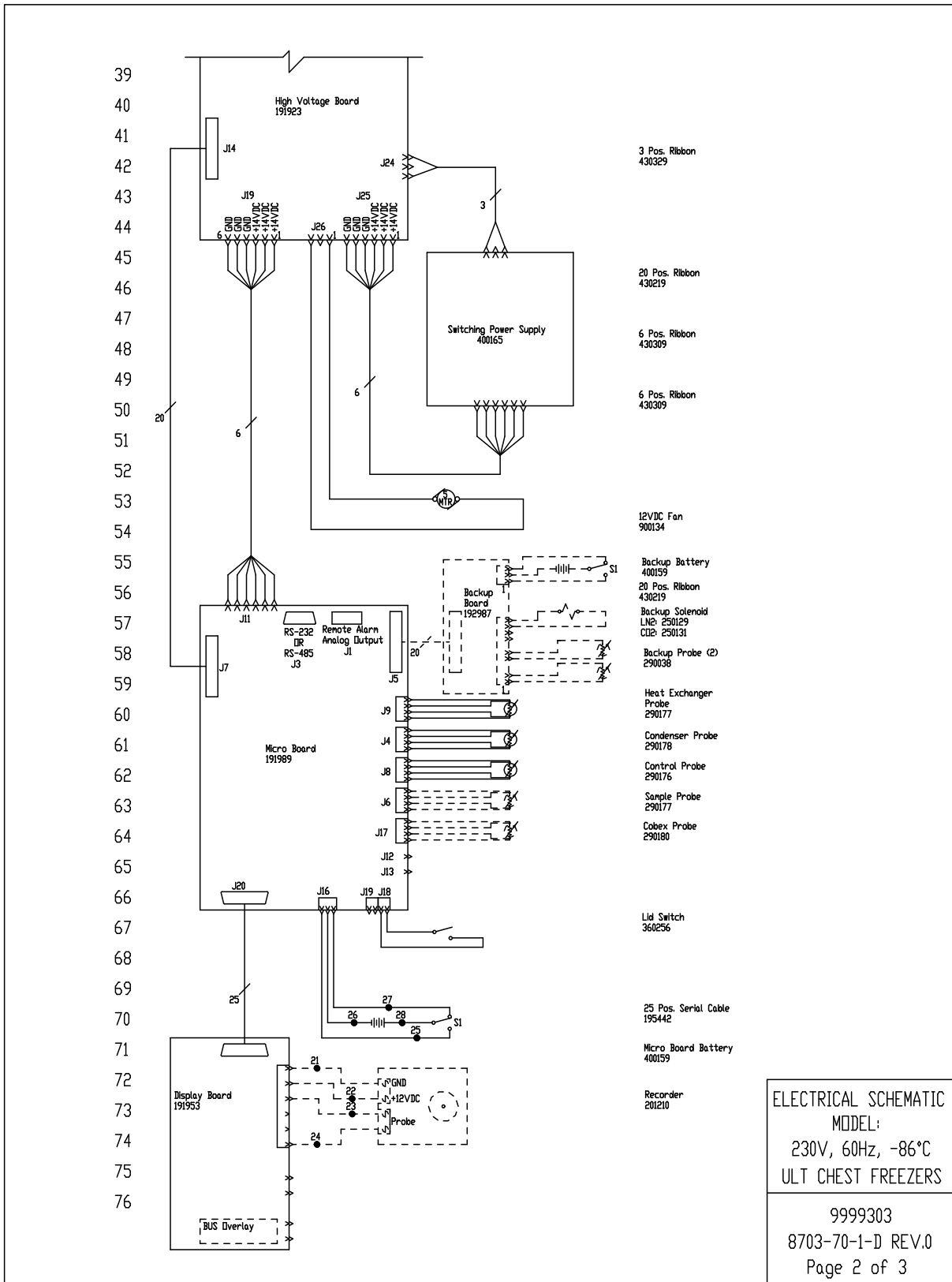
ELECTRICAL SCHEMATIC  
MODEL:  
230V, 50Hz, -86°C  
ULT CHEST FREEZERS

**ATTENTION**  
OBSERVE PRECAUTIONS  
ELECTROSTATIC  
SENSITIVE DEVICES

8702-70-2-D REV.0  
Page 3 of 3

**Section 10**  
Electrical Schematics







**Section 10**  
Electrical Schematics

WIRE #	COLOR	GAUGE	WIRE #	COLOR	GAUGE
1	BLK	14	29	-	-
2	RED	14	30	-	-
3	GRN/YEL	14	31	GRN/YEL	14
4	RED/WHT	14	32	BLK	14
5	BLK/WHT	14	33	BLU	14
6	BLK	18	34	BLK	14
7	BLK	18	35	BLU	14
8	BLK	18	36	BLK	14
9	BLK	18	37	BLU	14
10	BLK	18	38	BLK	14
11	BLK	18	39	BLU	14
14	GRN/YEL	18	40	BLK	14
17	GRN/YEL	14	41	BLU	14
18	GRN/YEL	14	42	BLK	14
19	BLK/WHT	14	43	BLU	14
20	BLK	14	44	BLK	14
21	BLK	18	45	BLU	14
22	RED	18	46	BLK	14
23	BLK	18	47	BLU	14
24	RED	18	48	BLK	14
25	WHT	18	49	BLU	14
26	BLK	18	50	BLK	14
27	BLK	18	51	BLU	14
28	RED	18	52	YEL/WHT	14
			53	YEL	14
			54	BLU/WHT	14
			55	BLU	14

**CHEST MODELS:**  
 12.7 CUFT. (230V) - 813CD, HFC1390TD, 1913CD, TSC1390D, ULT1390-10-D, VVRC1386D, 813CGPD, TSC1390GPD, ULT1390-10-GPD  
 17 CUFT. (230V) - 817CD, HFC1790TD, 1917CD, TSC1790D, ULT1790-10-D, 817CGPD, TSC1790GPD, ULT1790-10-GPD  
 20 CUFT. - 820CD, HFC2090TD, 1920CD, TSC2090D, ULT2090-10-D, VVRC2086D, 820CGPD, TSC2090GPD, ULT2090-10-GPD

**REMOTE CONTACTS/ANALOG OUTPUT**  
 PIN# 1 Analog Output +  
 PIN# 2 Analog Output -  
 PIN# 3 Not Connected  
 PIN# 4 Not Connected  
 PIN# 5 Normally Closed  
 PIN# 6 Common  
 PIN# 7 Normally Open

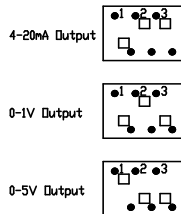
CONTACT RATING: 1A @ 30V  
 CONTACTS IN ALARM STATE

**RS-232 SPECIFICATION**

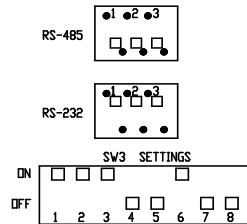
BAUD = 1200  
 PARITY = N  
 BITS = 8  
 STOP BITS = 2

**RS-232 PWR**  
 PIN# 2 TXD  
 PIN# 3 RXD  
 PIN# 5 GND

**SW1 Settings for Analog Output**



**SW2 Settings for Communication Output**



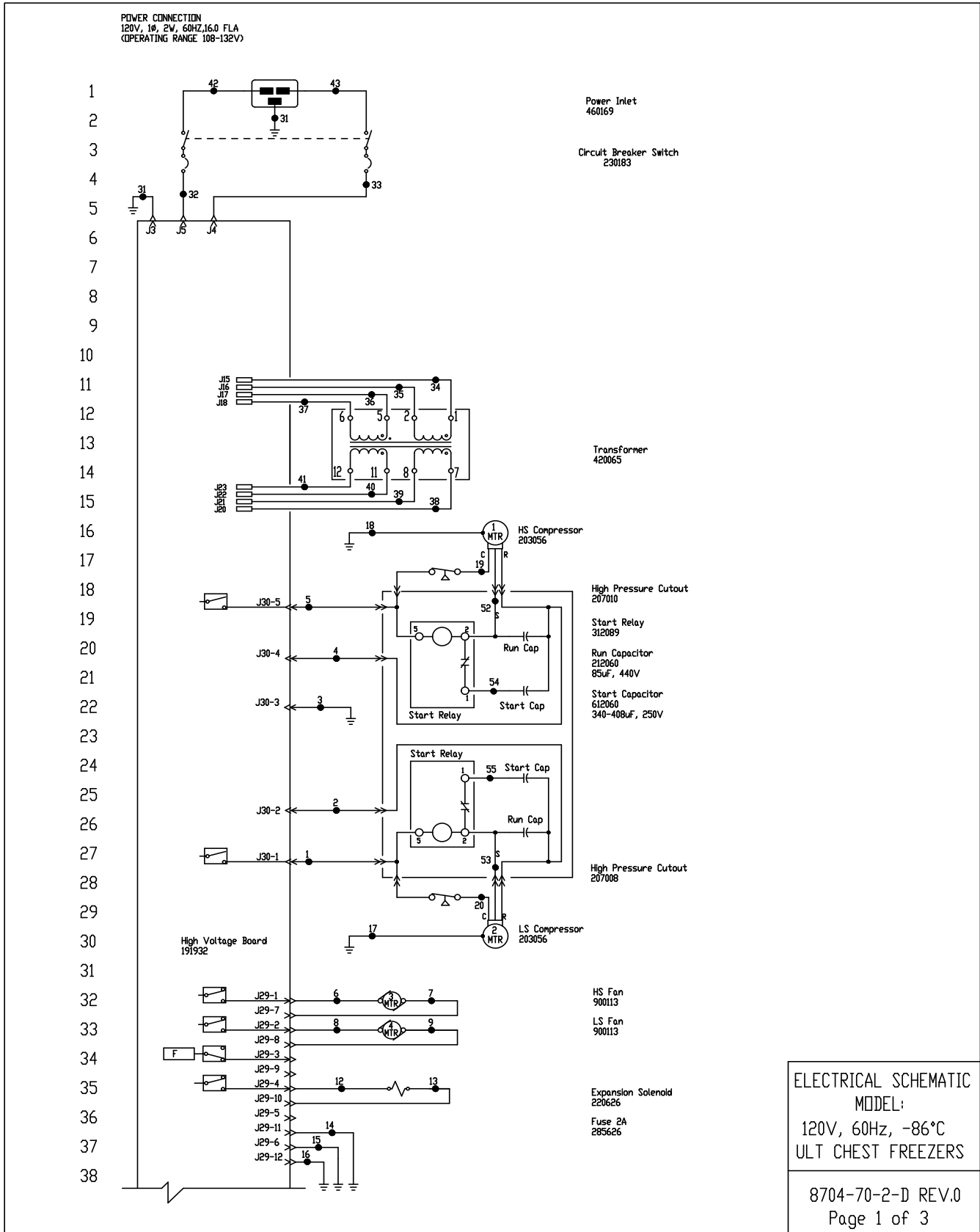
1. Schematic represents chest models.
2. Door switches shown in open position.
3. Battery switch shown in the OFF position.
4. Circuit breaker switch shown in OFF position.
5. Options and accessories shown in dashed lines.

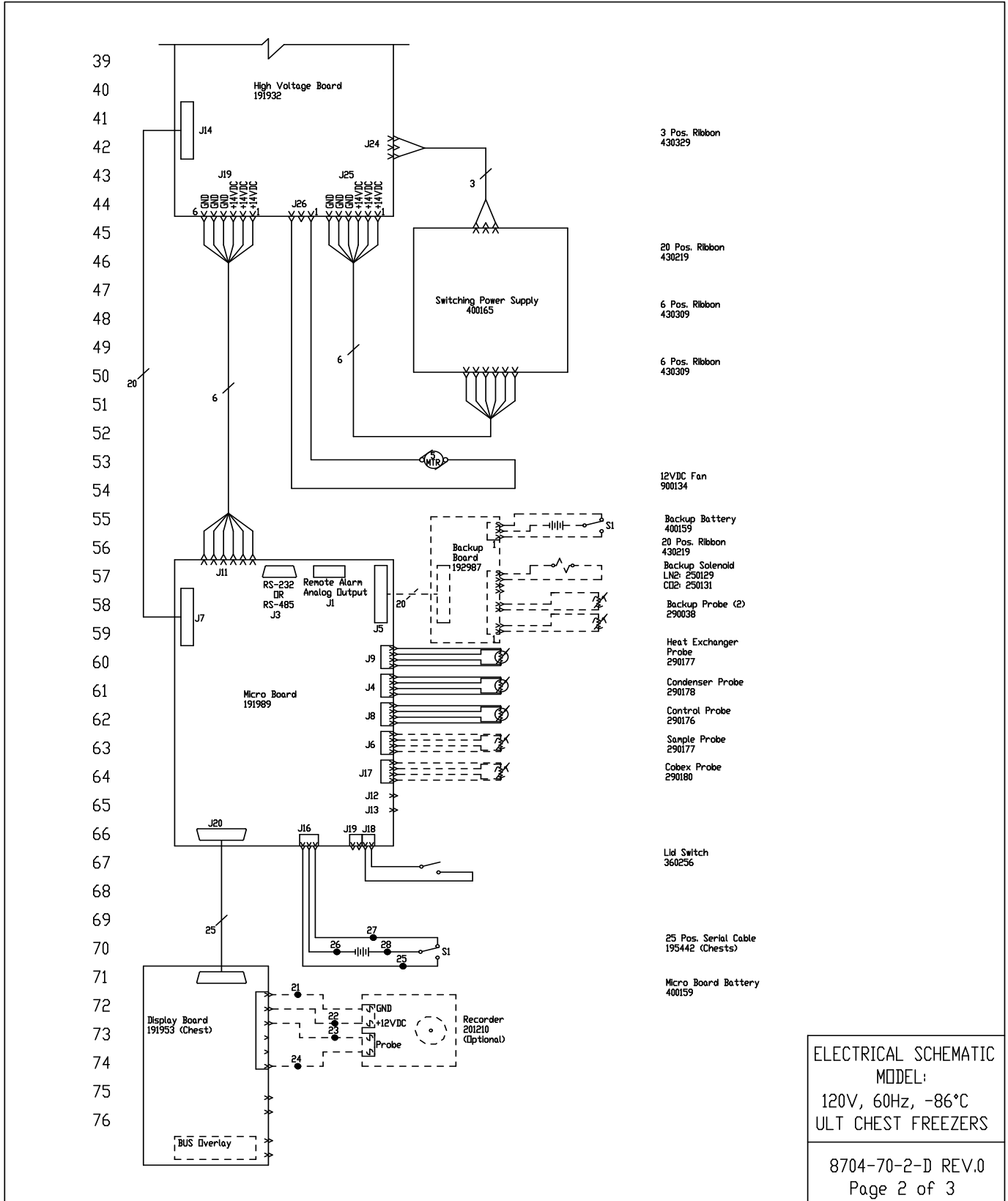
**ELECTRICAL SCHEMATIC**  
 MODEL:  
 230V, 60Hz, -86°C  
 ULT CHEST FREEZERS

**ATTENTION**  
 OBSERVE PRECAUTIONS  
 ELECTROSTATIC  
 SENSITIVE DEVICES

9999303  
 8703-70-1-D REV.0  
 Page 3 of 3

**Section 10**  
Electrical Schematics





77  
78  
79  
80  
81  
82  
83  
84  
85  
86  
87  
88  
89  
90  
91  
92  
93  
94  
95  
96  
97  
98  
99  
100  
101  
102  
103  
104  
105  
106  
107

WIRE #	COLOR	GAUGE	WIRE #	COLOR	GAUGE
1	BLK	14	29	-	-
2	RED	14	30	-	-
3	GRN/YEL	14	31	GRN/YEL	14
4	RED/WHT	14	32	BLK	14
5	BLK/WHT	14	33	BLU	14
6	BLK	18	34	BLK	14
7	BLK	18	35	BLU	14
8	BLK	18	36	BLK	14
9	BLK	18	37	BLU	14
10	BLK	18	38	BLK	14
11	BLK	18	39	BLU	14
12	BLK	18	40	BLK	14
13	BLK	18	41	BLU	14
14	GRN/YEL	18	42	BLK	14
15	GRN/YEL	18	43	BLU	14
16	GRN/YEL	18	44	-	-
17	GRN/YEL	14	45	-	-
18	GRN/YEL	14	46	-	-
19	BLK/WHT	14	47	-	-
20	BLK	14	48	-	-
21	BLK	18	49	-	-
22	RED	18	50	-	-
23	BLK	18	51	-	-
24	RED	18	52	YEL/WHT	14
25	WHT	18	53	YEL	14
26	BLK	18	54	BLU/WHT	14
27	BLK	18	55	BLU	14
28	RED	18			

CHEST MODELS:  
12.7 CU.FT. (120V) - 813CA, HFC1390TA, I913CA, TSC1390A, ULT1390-10-A, VVRC1386A  
17 CU.FT. (120V) - 817CA, HFC1790TA, I917CA, TSC1790A, ULT1790-10-A  
20 CU.FT. (120V) - 820CA, HFC2090TA, I920CA, TSC2090A, ULT2090-10-A, VVRC2086A

RS-232 SPECIFICATION

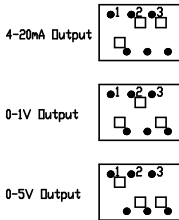
BAUD = 1200  
PARITY = N  
BITS = 8  
STOP BITS = 2

RS-232 PORT	
PIN# 2	TXD
PIN# 3	RXD
PIN# 5	GND

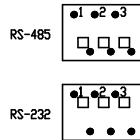
REMOTE CONTACTS/ANALOG OUTPUT	
PIN# 1	Analog Output +
PIN# 2	Analog Output -
PIN# 3	Not Connected
PIN# 4	Not Connected
PIN# 5	Normally Closed
PIN# 6	Common
PIN# 7	Normally Open

CONTACT RATING 1A @ 30V  
CONTACTS IN ALARM STATE

SW1 Settings for Analog Output



SW2 Settings for Communication Output



SW3 SETTINGS

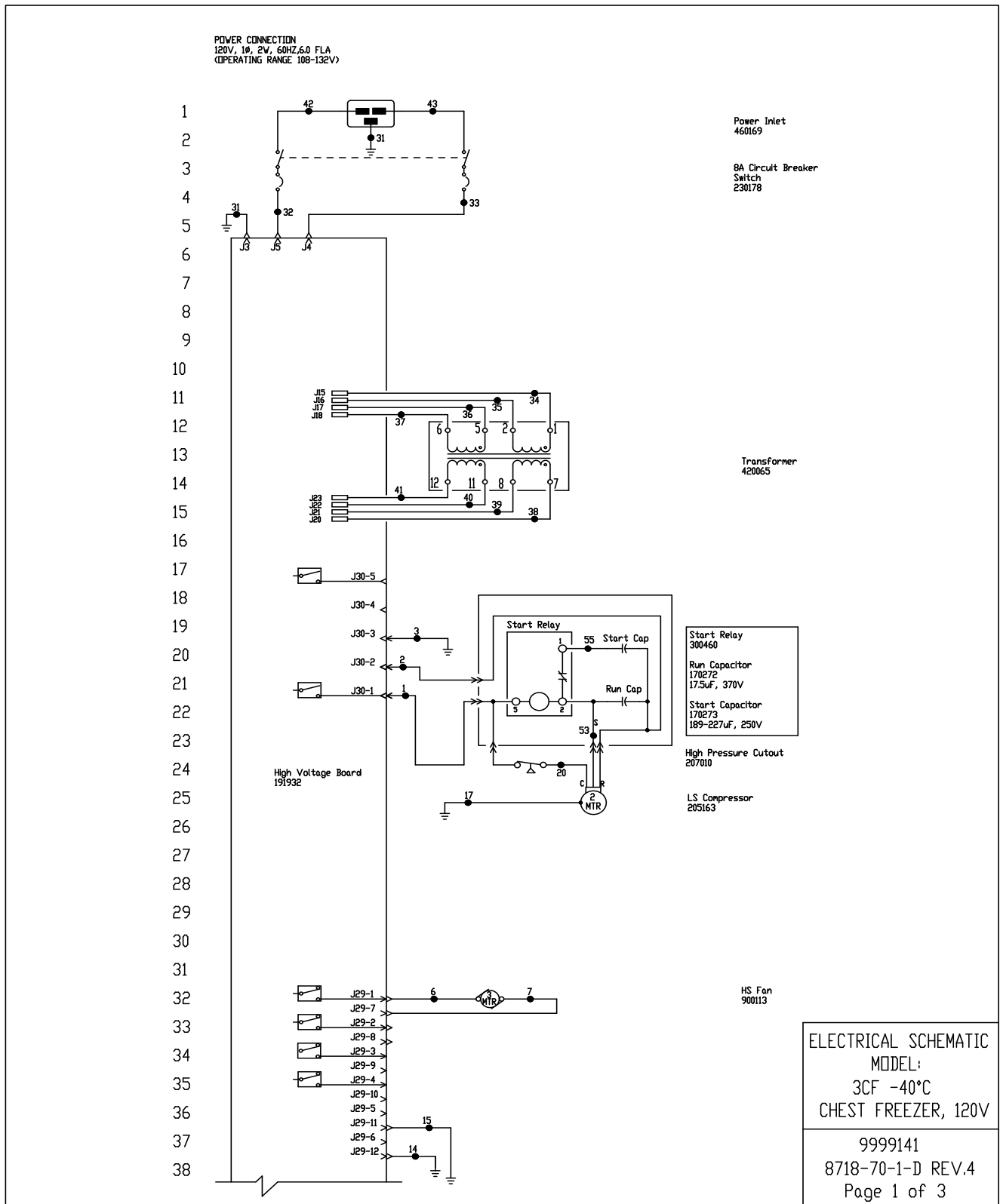


1. Schematic represents chest models.
2. Door switches shown in open position.
3. Battery switch shown in the OFF position.
4. Circuit breaker switch shown in OFF position.
5. Options and accessories shown in dashed lines.

**ATTENTION**  
OBSERVE PRECAUTIONS  
ELECTROSTATIC  
SENSITIVE DEVICES

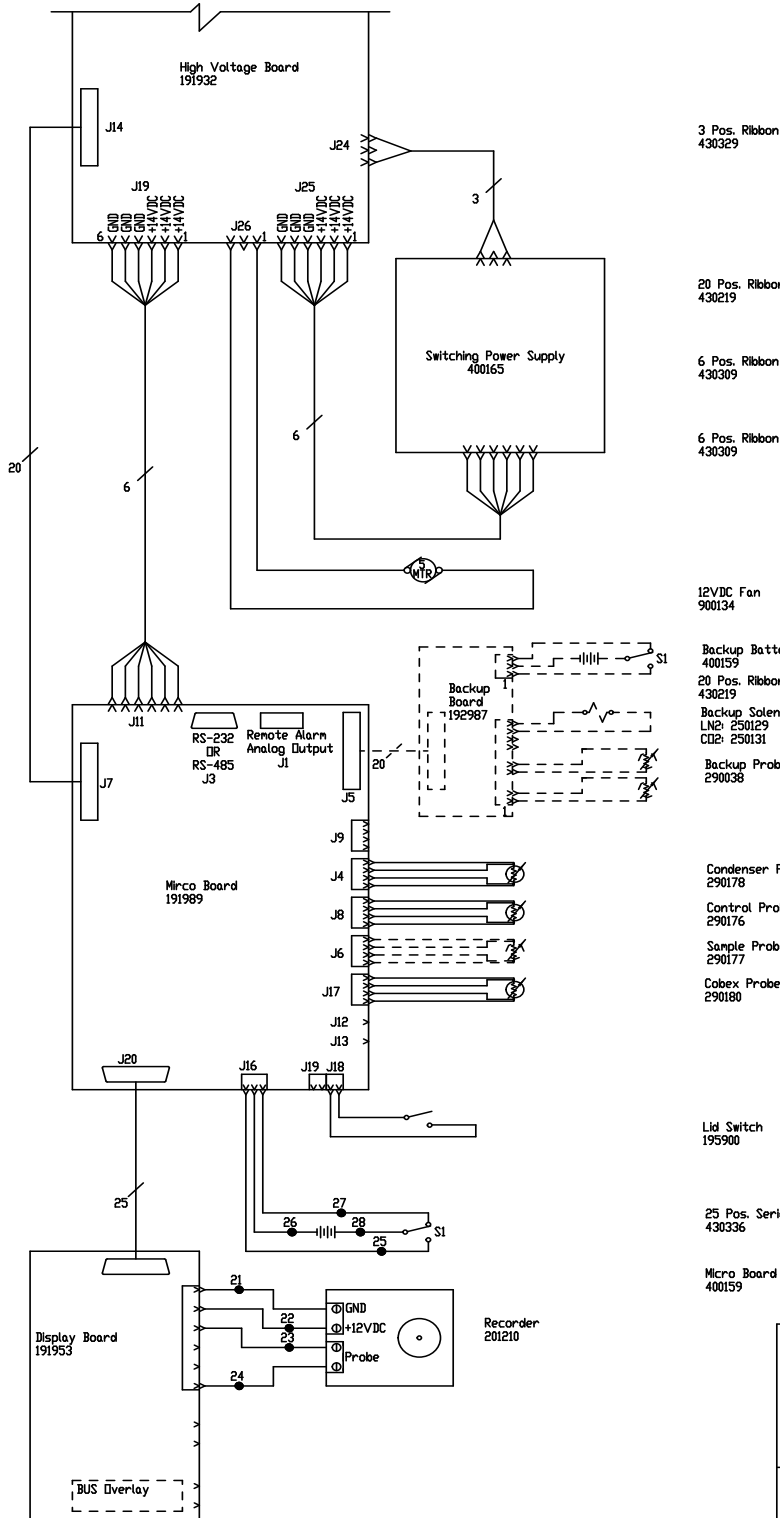
ELECTRICAL SCHEMATIC  
MODEL:  
120V, 60Hz, -86°C  
ULT CHEST FREEZERS

8704-70-2-D REV.0  
Page 3 of 3



**Section 10**  
Electrical Schematics

39  
40  
41  
42  
43  
44  
45  
46  
47  
48  
49  
50  
51  
52  
53  
54  
55  
56  
57  
58  
59  
60  
61  
62  
63  
64  
65  
66  
67  
68  
69  
70  
71  
72  
73  
74  
75  
76



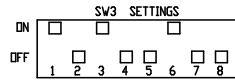
**ELECTRICAL SCHEMATIC**  
MODEL:  
3CF -40°C  
CHEST FREEZER, 120V

9999141  
8718-70-1-D REV.4  
Page 2 of 3

77  
78  
79  
80  
81  
82  
83  
84  
85  
86  
87  
88  
89  
90  
91  
92  
93  
94  
95  
96  
97  
98  
99  
100  
101  
102  
103  
104  
105  
106  
107

WIRE #	COLOR	GAUGE	WIRE #	COLOR	GAUGE
1	BLK	14	25	WHT	18
2	RED	14	26	BLK	18
3	GRN/YEL	14	27	BLK	18
4			28	RED	18
5			29		
6	BLK	18	30		
7	BLK	18	31	GRN/YEL	14
8	BLK	18	32	BLK	14
9	BLK	18	33	BLU	14
10			34	BLK	14
11			35	BLU	14
12			36	BLK	14
13			37	BLU	14
14	GRN/YEL	18	38	BLK	14
15	GRN/YEL	18	39	BLU	14
16			40	BLK	14
17	GRN/YEL	14	41	BLU	14
18			42	BLK	14
19			43	BLU	14
20	BLK	14			
21	BLK	18			
22	RED	18			
23	BLK	18			
24	RED	18			

MODELS:  
3 CUFT. CHEST MODELS (120V) - 703CA, HFC350TA, TSC350A, ULT350-10-A



RS-232 SPECIFICATION

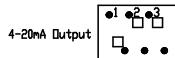
REMOTE CONTACTS/ANALOG OUTPUT  
PIN# 1 Analog Output +  
PIN# 2 Analog Output -  
PIN# 3 Not Connected  
PIN# 4 Not Connected  
PIN# 5 Normally Closed  
PIN# 6 Common  
PIN# 7 Normally Open

BAUD = 1200  
PARITY = N  
BITS = 8  
STOP BITS = 2

RS-232 PDIRT  
PIN# 2 TXD  
PIN# 3 RXD  
PIN# 5 GND

CONTACT RATING: 1A @ 30V  
CONTACTS IN ALARM STATE

SW1 Settings for Analog Output



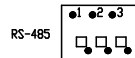
0-1V Output



0-5V Output



SW2 Settings for Communication Output



RS-232



1. Door switch shown in open position.
2. Battery switch shown in the OFF position.
3. Circuit breaker switch shown in OFF position.
4. Options and accessories shown in dashed lines.

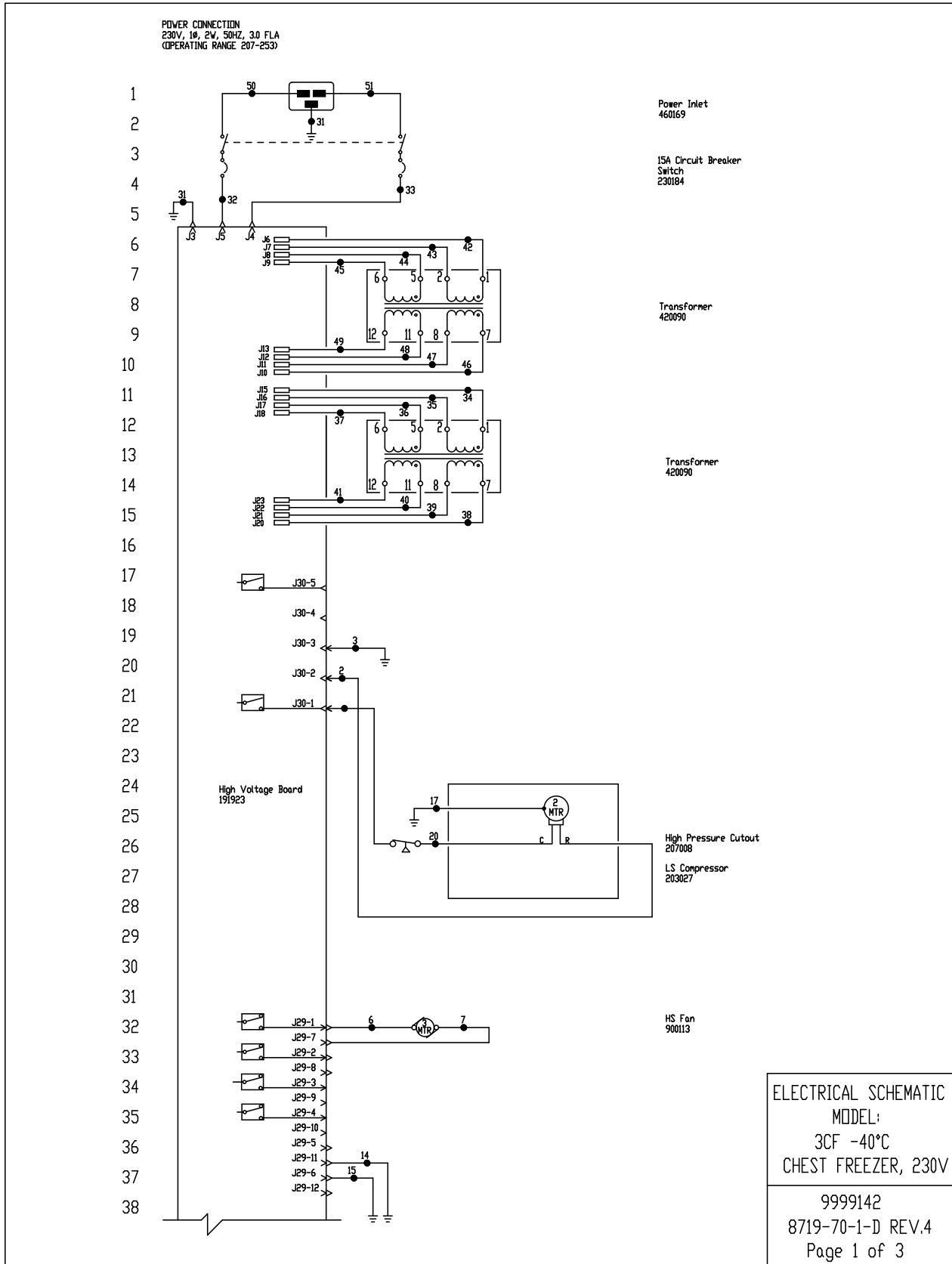
ELECTRICAL SCHEMATIC  
MODEL:  
3CF -40°C  
CHEST FREEZER, 120V



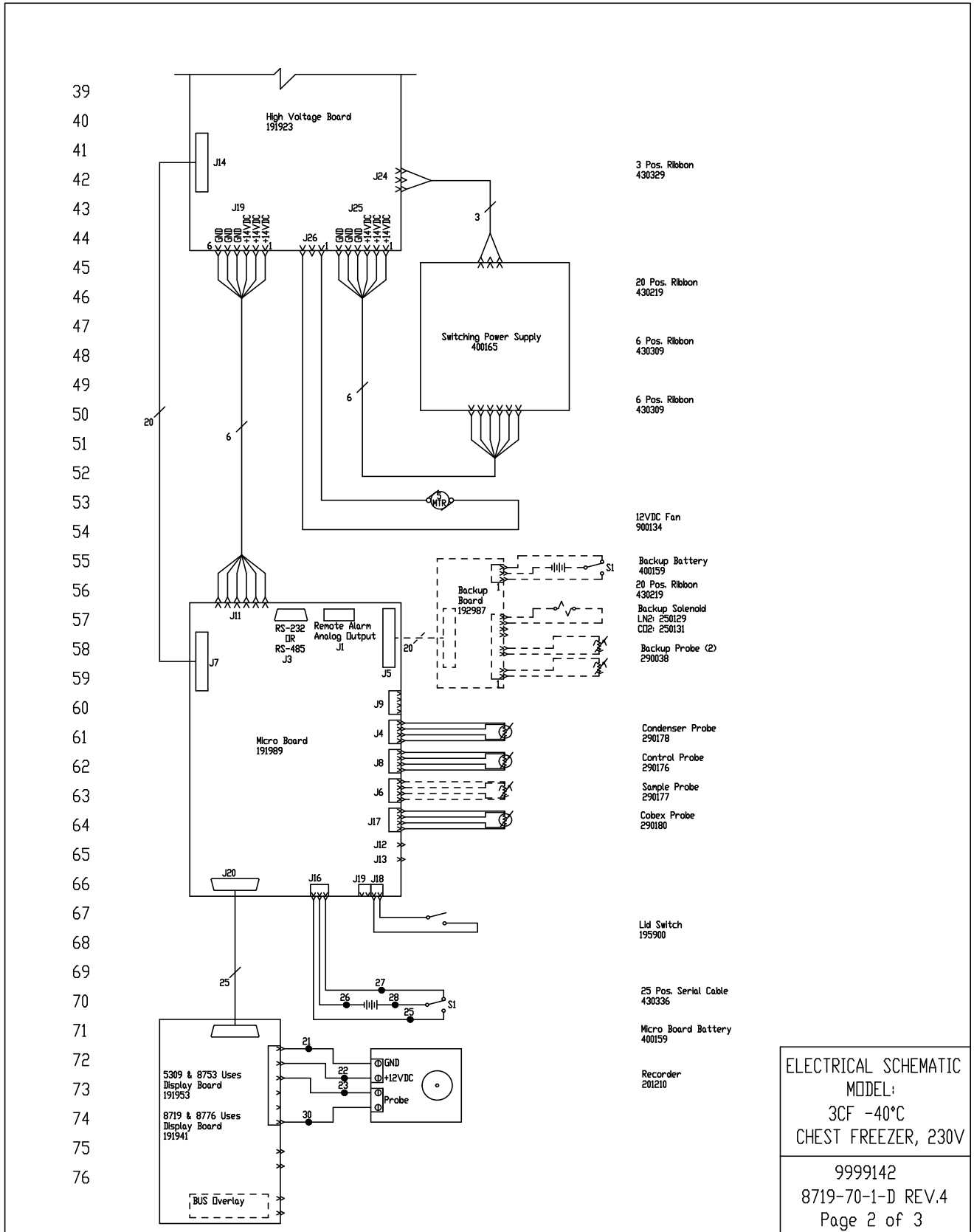
ATTENTION  
OBSERVE PRECAUTIONS  
ELECTROSTATIC  
SENSITIVE DEVICES

9999141  
8718-70-1-D REV.4  
Page 3 of 3

**Section 10**  
Electrical Schematics







**Section 10**  
Electrical Schematics

77

78

79

80

81

82

83

84

85

86

87

88

89

90

91

92

93

94

95

96

97

98

99

100

101

102

103

104

105

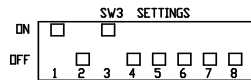
106

107

WIRE #	COLOR	GAUGE	WIRE #	COLOR	GAUGE
1	BLK	14	25	WHT	18
2	RED	14	26	BLK	18
3	GRN/YEL	14	27	BLK	18
4			28	RED	18
5			29		
6	BLK	18	30	RED	18
7	BLK	18	31	GRN/YEL	14
8	BLK	18	32	BLK	14
9	BLK	18	33	BLU	14
10			34	BLK	14
11			35	BLU	14
12			36	BLK	14
13			37	BLU	14
14	GRN/YEL	18	38	BLK	14
15	GRN/YEL	18	39	BLU	14
16			40	BLK	14
17	GRN/YEL	14	41	BLU	14
18			42	BLK	14
19			43	BLU	14
20	BLK	14	44	BLK	14
21	BLK	18	45	BLU	14
22	RED	18	46	BLK	14
23	BLK	18	47	BLU	14
24			48	BLK	14
			49	BLU	14
			50	BLK	14
			51	BLU	14

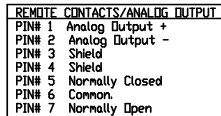
**MODELS:**

3 CU.FT. CHEST MODELS (230V) - 703CV, HFC350TV, TSC350V, ULT350-10-V



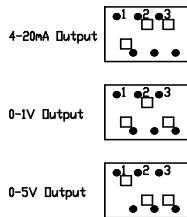
**RS-232 SPECIFICATION**

BAUD = 1200  
PARITY = N  
BITS = 8  
STOP BITS = 2

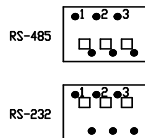


CONTACT RATING: 1A @ 30V  
CONTACTS IN ALARM STATE

**SW1 Settings for Analog Output**

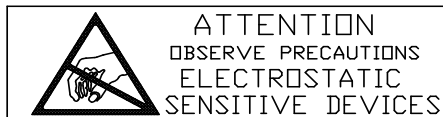


**SW2 Settings for Communication Output**

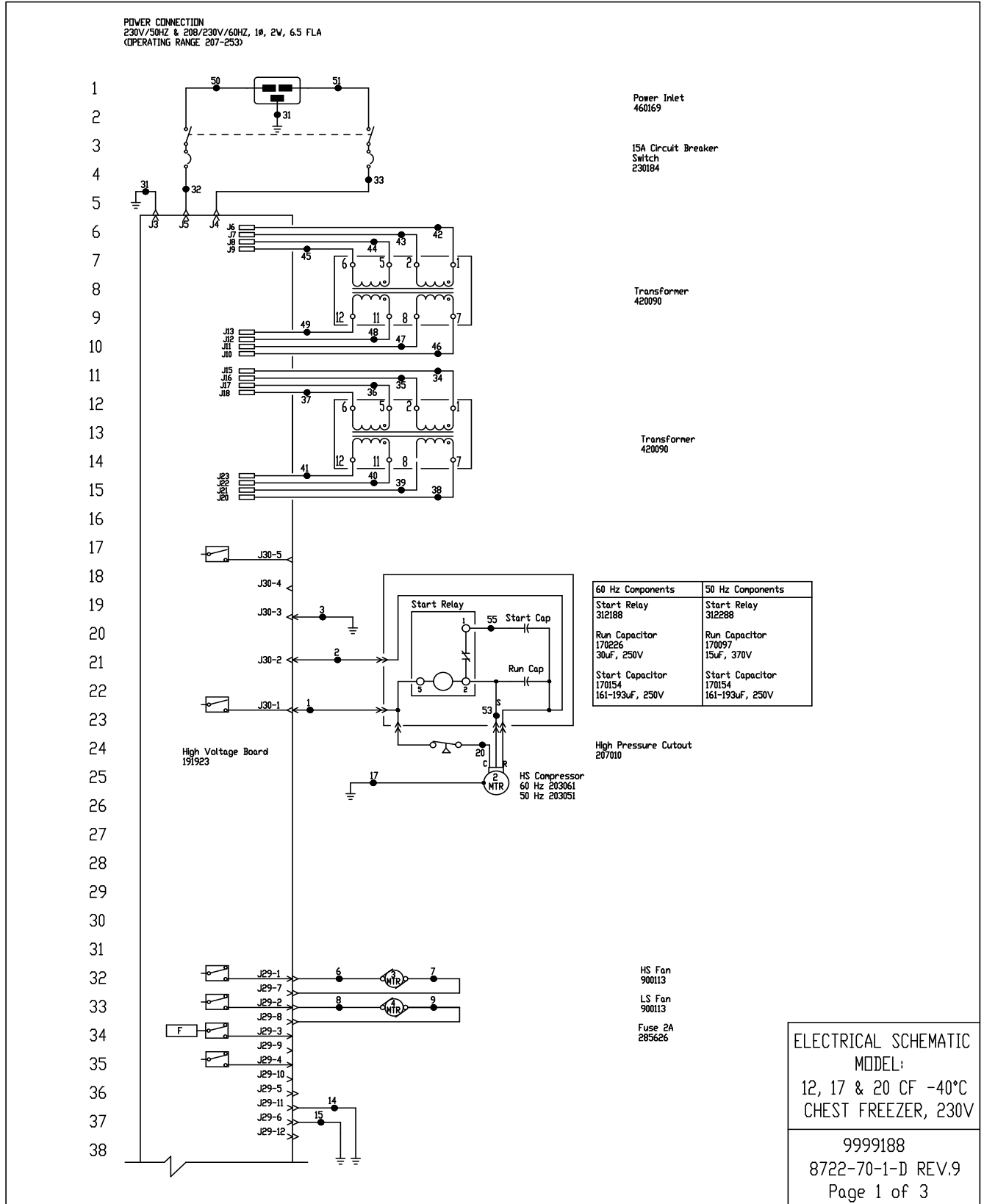


1. Door switch shown in open position.
2. Battery switch shown in the OFF position.
3. Circuit breaker switch shown in OFF position.
4. Options and accessories shown in dashed lines.

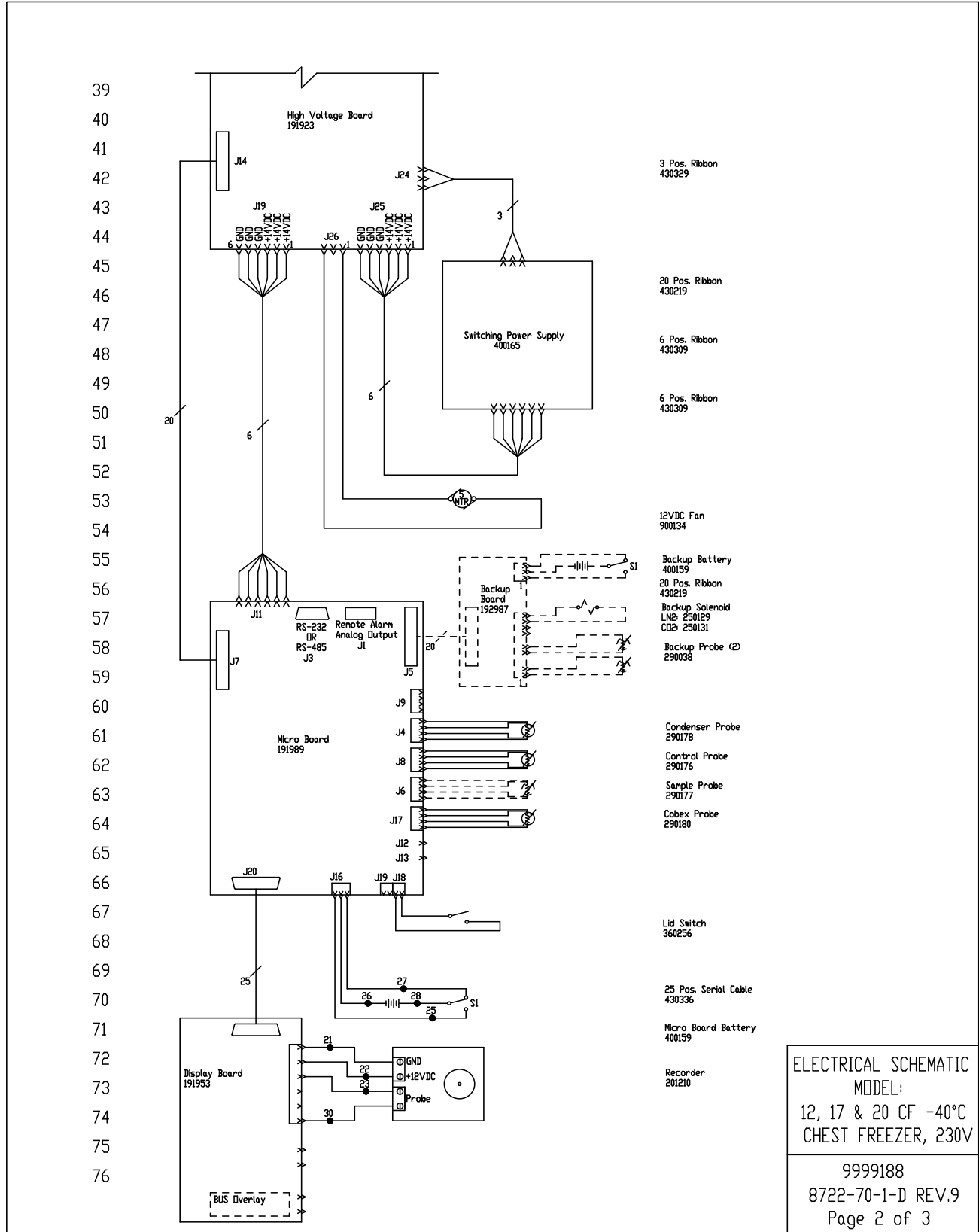
**ELECTRICAL SCHEMATIC**  
MODEL:  
3CF -40°C  
CHEST FREEZER, 230V



9999142  
8719-70-1-D REV.4  
Page 3 of 3



**Section 10**  
Electrical Schematics



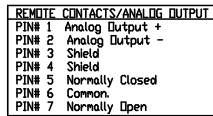
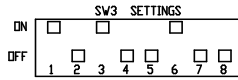
**ELECTRICAL SCHEMATIC**  
MODEL:  
12, 17 & 20 CF -40°C  
CHEST FREEZER, 230V

9999188  
8722-70-1-D REV.9  
Page 2 of 3

77  
78  
79  
80  
81  
82  
83  
84  
85  
86  
87  
88  
89  
90  
91  
92  
93  
94  
95  
96  
97  
98  
99  
100  
101  
102  
103  
104  
105  
106  
107

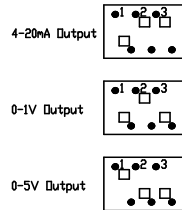
WIRE #	COLOR	GAUGE	WIRE #	COLOR	GAUGE
1	BLK	14	29	RED	18
2	RED	14	30	GRN/YEL	14
3	GRN/YEL	14	31	BLK	14
4			32	BLU	14
5			33	BLK	14
6	BLK	18	34	BLU	14
7	BLK	18	35	BLU	14
8	BLK	18	36	BLK	14
9	BLK	18	37	BLU	14
10			38	BLK	14
11			39	BLU	14
12			40	BLK	14
13			41	BLU	14
14	GRN/YEL	18	42	BLK	14
15	GRN/YEL	18	43	BLU	14
16			44	BLK	14
17	GRN/YEL	14	45	BLU	14
18			46	BLK	14
19			47	BLU	14
20	BLK	14	48	BLK	14
21	BLK	18	49	BLU	14
22	RED	18	50	BLK	14
23	BLK	18	51	BLU	14
24			52	-	-
25	WHT	18	53	YEL	14
26	BLK	18	54	-	-
27	BLK	18	55	BLU	14
28	RED	18			

CHEST MODELS:  
12.7 CU.FT. (230V) - 713CD, HFC1350TD, TSC1350D, ULT1350-10-D, 713CV, HFC1350TV, TSC1350V  
ULT1350-10-V, 713CGPD, TSC1350GPD, ULT1350-10-GPD  
17 CU.FT. (230V) - 717CD, HFC1750TD, TSC1750D, ULT1750-10-D, 717CV, HFC1750TV, TSC1750V  
ULT1750-10-V, 717CGPD, TSC1750GPD, ULT1750-10-GPD  
20 CU.FT. (230V) - 720CD, HFC2050TD, TSC2050D, ULT2050-10-D, 720CV, HFC2050TV, TSC2050V  
ULT2050-10-V, 720CGPD, TSC2050GPD, ULT2050-10-GPD



CONTACT RATING 1A @ 30V  
CONTACTS IN ALARM STATE

SW1 Settings for Analog Output

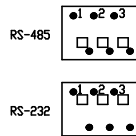


RS-232 SPECIFICATION

BAUD = 1200  
PARITY = N  
BITS = 8  
STOP BITS = 2



SW2 Settings for Communication Output



1. Door switch shown in open position.
2. Battery switch shown in the OFF position.
3. Circuit breaker switch shown in OFF position.
4. Options and accessories shown in dashed lines.

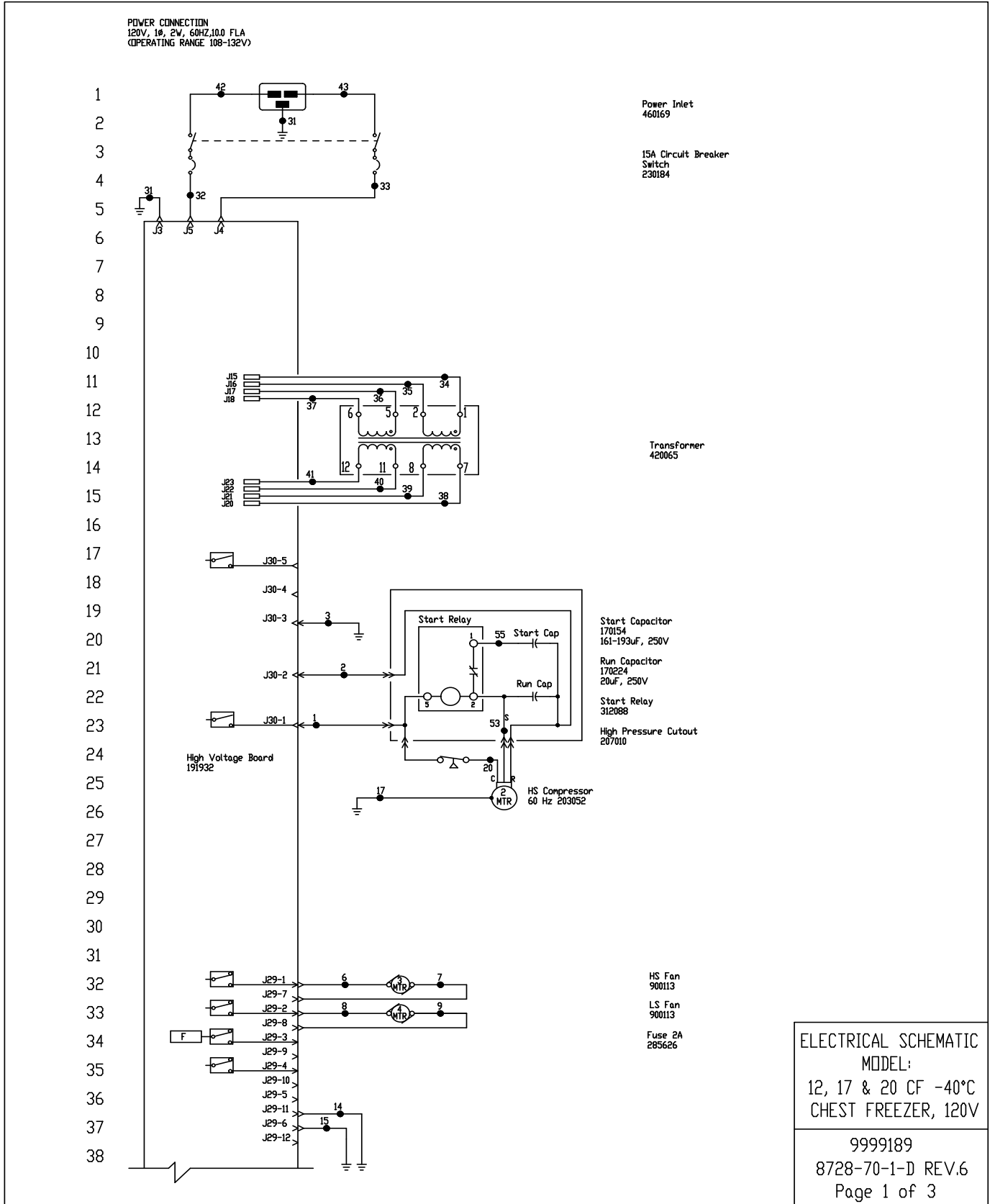
ELECTRICAL SCHEMATIC  
MODEL:  
12, 17 & 20 CF -40°C  
CHEST FREEZER, 230V



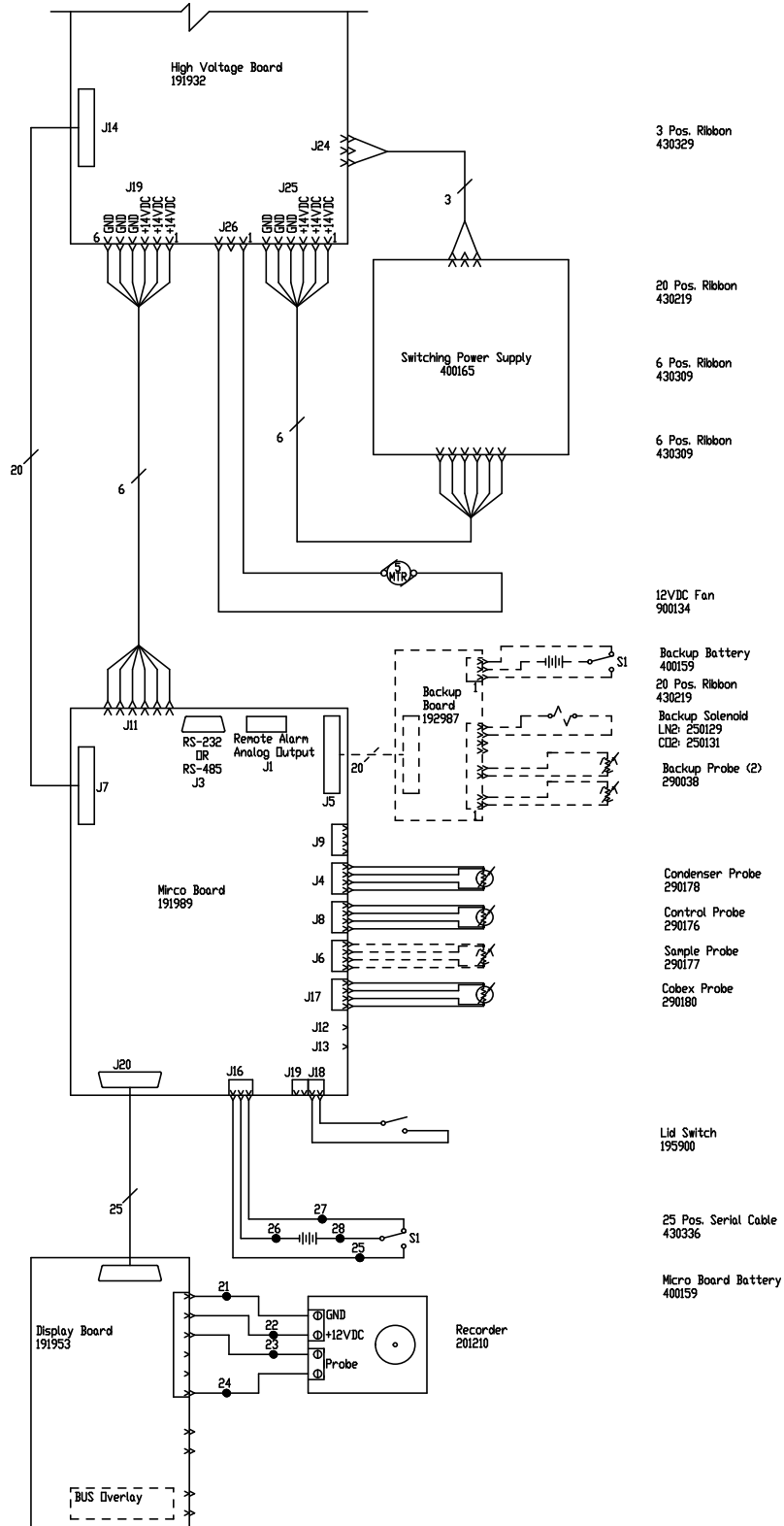
ATTENTION  
OBSERVE PRECAUTIONS  
ELECTROSTATIC  
SENSITIVE DEVICES

9999188  
8722-70-1-D REV.9  
Page 3 of 3

**Section 10**  
Electrical Schematics



39  
40  
41  
42  
43  
44  
45  
46  
47  
48  
49  
50  
51  
52  
53  
54  
55  
56  
57  
58  
59  
60  
61  
62  
63  
64  
65  
66  
67  
68  
69  
70  
71  
72  
73  
74  
75  
76



ELECTRICAL SCHEMATIC  
MODEL:  
12, 17 & 20 CF -40°C  
CHEST FREEZER, 120V

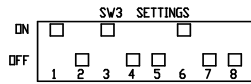
---

9999189  
8728-70-1-D REV.6  
Page 2 of 3

77  
78  
79  
80  
81  
82  
83  
84  
85  
86  
87  
88  
89  
90  
91  
92  
93  
94  
95  
96  
97  
98  
99  
100  
101  
102  
103  
104  
105  
106  
107

WIRE #	COLOR	GAUGE	WIRE #	COLOR	GAUGE
1	BLK	14	29		
2	RED	14	30		
3	GRN/YEL	14	31	GRN/YEL	14
4			32	BLK	14
5			33	BLU	14
6	BLK	18	34	BLK	14
7	BLK	18	35	BLU	14
8	BLK	18	36	BLK	14
9	BLK	18	37	BLU	14
10			38	BLK	14
11			39	BLU	14
12			40	BLK	14
13			41	BLU	14
14	GRN/YEL	18	42	BLK	14
15	GRN/YEL	18	43	BLU	14
16			44	-	-
17	GRN/YEL	14	45	-	-
18			46	-	-
19			47	-	-
20	BLK	14	48	-	-
21	BLK	18	49	-	-
22	RED	18	50	-	-
23	BLK	18	51	-	-
24	RED	18	52	-	-
25	WHT	18	53	YEL	-
26	BLK	18	54	-	-
27	BLK	18	55	BLU	-
28	RED	18			

CHEST MODELS:  
12.7 CU.FT.(120V) - 713CA, HFC1350TA, TSC1350A, ULTI1350-10-A  
17 CU.FT.(120V) - 717CA, HFC1750TA, TSC1750A, ULTI1750-10-A  
20 CU.FT.(120V) - 720CA, HFC2050TA, TSC2050A, ULTI2050-10-A

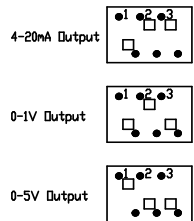


REMOTE CONTACTS/ANALOG OUTPUT  
PIN# 1 Analog Output +  
PIN# 2 Analog Output -  
PIN# 3 Not Connected  
PIN# 4 Not Connected  
PIN #5 Normally Closed  
PIN# 6 Common  
PIN# 7 Normally Open  
CONTACT RATING 1A @ 30V  
CADCONTACTS IN ALARM STATE

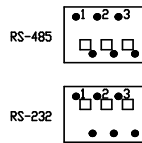
RS-232 SPECIFICATION  
BAUD = 1200  
PARITY = N  
BITS = 8  
STOP BITS = 2

RS-232 PORT  
PIN# 2 TXD  
PIN# 3 RXD  
PIN# 5 GND

SW1 Settings for Analog Output



SW2 Settings for Communication Output



1. Door switch shown in open position.
2. Battery switch shown in the OFF position.
3. Circuit breaker switch shown in OFF position.
4. Options and accessories shown in dashed lines.

ELECTRICAL SCHEMATIC  
MODEL:  
12, 17 & 20 CF -40°C  
CHEST FREEZER, 120V



9999189  
8728-70-1-D REV.6  
Page 3 of 3



## **THERMO FISHER SCIENTIFIC FREEZER WARRANTY**

The Warranty Period starts two weeks from the date your equipment is shipped from our facility. This allows for shipping time so the warranty will go into effect at approximately the same time your equipment is delivered. The warranty protection extends to any subsequent owner during the warranty period.

During the first two years of the warranty period, component parts proven to be non-conforming in materials or workmanship will be repaired or replaced at Thermo's expense, labor included. The ULT Freezers include an additional two year warranty on the compressors, parts only, F.O.B. factory. Installation and calibration is not covered by this warranty agreement. The Technical Services Department must be contacted for warranty determination and direction prior to any work being performed. Expendable items, i.e., glass, filters, pilot lights, light bulbs and door gaskets are excluded from this warranty.

Replacement or repair of component parts or equipment under this warranty shall not extend the warranty to either the equipment or to the component part beyond the original two year warranty period. The Technical Services Department must give prior approval for the return of any components or equipment.

**THIS WARRANTY IS EXCLUSIVE AND IN LIEU OF ALL OTHER WARRANTIES, WHETHER WRITTEN, ORAL, OR IMPLIED. NO WARRANTIES OF MERCHANTABILITY OR FITNESS FOR A PARTICULAR PURPOSE SHALL APPLY.** Thermo shall not be liable for any indirect or consequential damages including, without limitation, damages relating to lost profits or loss of products.

Your local Thermo Sales Office is ready to help with comprehensive site preparation information before your equipment arrives. Printed instruction manuals carefully detail equipment installation with operation, preventive maintenance and maintenance information on an included CD.

If equipment service is required, please call your Technical Services Department at 1-800-438-4851 (USA and Canada) or 1-740-373-4763. We're ready to answer your questions on equipment warranty, operation, maintenance, service, and special applications. Outside the USA, contact your local Thermo Scientific office or distributor for warranty information.



Rev. 10/14

## **THERMO FISHER SCIENTIFIC FREEZER INTERNATIONAL DEALER WARRANTY**

The Warranty Period starts two months from the date your equipment is shipped from our facility. This allows for shipping time so the warranty will go into effect at approximately the same time your equipment is delivered. The warranty protection extends to any subsequent owner during the warranty period. Dealers who stock our equipment are allowed an additional four months for delivery and installation, providing the warranty is registered online.

During the first two years of the warranty period, component parts proven to be non-conforming in materials or workmanship will be repaired or replaced at Thermo's expense, labor excluded. The ULT Freezers include an additional two year warranty on the compressors, parts only, F.O.B. factory. Installation and calibration is not covered by this warranty agreement. The Technical Services Department must be contacted for warranty determination and direction prior to any work being performed. Expendable items, i.e., glass, filters, pilot lights, light bulbs and door gaskets are excluded from this warranty.

Replacement or repair of component parts or equipment under this warranty shall not extend the warranty to either the equipment or to the component part beyond the original two year warranty period. The Technical Services Department must give prior approval for the return of any components or equipment.

**THIS WARRANTY IS EXCLUSIVE AND IN LIEU OF ALL OTHER WARRANTIES, WHETHER WRITTEN, ORAL, OR IMPLIED. NO WARRANTIES OF MERCHANTABILITY OR FITNESS FOR A PARTICULAR PURPOSE SHALL APPLY. Thermo shall not be liable for any indirect or consequential damages including, without limitation, damages relating to lost profits or loss of products.**

Your local Thermo Sales Office is ready to help with comprehensive site preparation information before your equipment arrives. Printed instruction manuals carefully detail equipment installation with operation, preventive maintenance and maintenance information on an included CD.

If equipment service is required, please call your local distributor or the Technical Services Department at 1-800-438-4851 (USA and Canada) or 1-740-373-4763. We're ready to answer your questions on equipment warranty, operation, maintenance, service, and special applications. Outside the USA, contact your local Thermo Scientific office or distributor for warranty information.



Rev. 10/14

# Section 12 Regulatory Compliance

## Product Safety

This product family has been tested to applicable product standards by UL and TUV SUD, Nationally Recognized Test Laboratories (NRTL).



## Fluorinated Gas Refrigerant Service Notes

Compliant with Regulation (EU) No 517/2014 of the European Parliament and of the Council on fluorinated greenhouse gases. This product contains fluorinated greenhouse gases in a hermetically sealed system. If a leak in the sealed system is detected, the operator shall repair without undue delay.

This unit contains fluorinated refrigerants (F-Gases). Because of the nature of F-gasses, for mechanical repair, such as recharge or compressor replacement, should only be carried out by a certified refrigeration technician.

In conformity with Article 14 of Regulation (EU) No 517/2014 of the European Parliament and of the Council, a declaration of conformity for F-Gas has been supplied with this unit. Please refer to that document for details regarding our compliance to this regulation.

## Electromagnetic Compatibility

### FCC Statement (USA)



Any changes or modifications not expressly approved by the party responsible for compliance could void the user's authority to operate the equipment.

**Note** This equipment has been tested and found to comply with the limits for a Class A digital device, pursuant to part 15 of the FCC Rules. These limits are designed to provide reasonable protection against harmful interference when the equipment is operated in a commercial environment.

## Electromagnetic Compatibility

This equipment generates, uses, and can radiate radio frequency energy and, if not installed and used in accordance with the instruction manual, may cause harmful interference to radio communications. Operation of this equipment in a residential area is likely to cause harmful interference in which case the user will be required to correct the interference at his own expense.

### Canadian ISED IC Notice

This class B digital apparatus complies with Canadian ICES-001.  
Cet appareil numérique de la classe B est conforme à la norme NMB-001 du Canada.

**WARNING** Statement: EMC Registration is done on this equipment for business use only. It may cause interference when the product would be used in home. This warning statement applies a product for business use.

## Evaluation of Chemicals - Regulations and Directives

### REACH - Europe

We are committed to meeting all compliance obligations to evaluate, communicate, and register any Substances of Very High Concern (SVHC), and finding alternates where appropriate.

### RoHS - Europe

- We are determined to reduce the impact we have on the environment, and so can declare that this product fully complies with the European Parliament's RoHS2 (Restriction of Hazardous Substances) Directive 2011/65/EU, with respect to all the following substances:
  - Lead (0,1 %)
  - Mercury (0,1 %)
  - Cadmium (0,01 %)
  - Hexavalent chromium (0,1 %)
  - Polybrominated biphenyls (PBB) (0,1 %)
  - Polybrominated diphenyl ethers (PBDE) (0,1 %)

2015/863 Annex II (RoHS3, In effect after July 22, 2019)

- Bis(2-ethylhexyl) phthalate (DEHP) (0,1 %)
- Butyl benzyl phthalate (BBP) (0,1 %)
- Dibutyl phthalate (DBP) (0,1 %)
- Diisobutyl phthalate (DIBP) (0,1 %)

Our compliance is witnessed by written declaration from our suppliers and/or component testing. This confirms that any potential trace contamination levels of the substances listed above are below the maximum level set by the latest regulations or are exempt due to their application.

## Evaluation of Chemicals - Regulations and Directives (cont.)

### RoHS – China

This product complies with the requirements of the legislative act Administration on the Control of Pollution Caused by Electronic Information Products (ACPEIP). A label of conformance, such as one of the following, may be found on the product:



## Additional Regulations & Markings

### European Union



The European voltages of this product meets all the applicable requirements of the European Directives, and display the CE Marking. An EC declaration of conformity may be obtained from the manufacturer.

## End of Life Care

Be sure to follow local regulations when disposing of an old unit. Some suggestions are listed below:

- Remove items and defrost unit. Be sure to clean up any biological safety hazards.
- Remove the cabinet door to help prevent entrapment inside of a unit.
- Have a certified technician remove the refrigerant and compressor, then drain the compressor and oil from the system. Dispose of components following local regulations.

## WEEE Compliance

**WEEE Compliance.** This product is required to comply with the European Union's Waste Electrical & Electronic Equipment (WEEE) Directive 2012/19/EU. It is marked with the following symbol. Thermo Fisher Scientific has contracted with one or more recycling/disposal companies in each EU Member State, and this product should be disposed of or recycled through them. Further information on our compliance with these Directives, the recyclers in your country, and information on Thermo Scientific products which may assist the detection of substances subject to the RoHS Directive are available at [www.thermofisher.com/](http://www.thermofisher.com/)

Great Britain



**WEEE Konformität.** Dieses Produkt muss die EU Waste Electrical & Electronic Equipment (WEEE) Richtlinie 2012/19/EU erfüllen. Das Produkt ist durch folgendes Symbol gekennzeichnet. Thermo Fisher Scientific hat Vereinbarungen getroffen mit Verwertungs-/Entsorgungsanlagen in allen EU-Mitgliederstaaten und dieses Produkt muss durch diese Firmen wiederverwertet oder entsorgt werden. Mehr Informationen über die Einhaltung dieser Anweisungen durch Thermo Scientific, die Verwerter und Hinweise die Ihnen nützlich sein können, die Thermo Fisher Scientific Produkte zu identifizieren, die unter diese RoHS. Anweisung fallen, finden Sie unter [www.thermofisher.com/](http://www.thermofisher.com/)

Deutschland



**Conformità WEEE.** Questo prodotto deve rispondere alla direttiva dell'Unione Europea 2012/19/EU in merito ai Rifiuti degli Apparecchi Elettrici ed Elettronici (WEEE), marcato col seguente simbolo. Thermo Fisher Scientific ha stipulato contratti con una o diverse società di riciclaggio/smaltimento in ognuno degli Stati Membri Europei. Questo prodotto verrà smaltito o riciclato tramite queste medesime. Ulteriori informazioni sulla conformità di Thermo Fisher Scientific con queste Direttive, l'elenco delle ditte di riciclaggio nel Vostro paese e informazioni sui prodotti Thermo Scientific che possono essere utili alla rilevazione di sostanze soggette alla Direttiva RoHS sono disponibili sul sito <http://www.thermofisher.com/>

Italia



## WEEE Compliance (cont.)

**Conformité WEEE.** Ce produit doit être conforme à la directive euro-péenne (2012/19/EU) des Déchets d'Equipements Electriques et Electroniques (DEEE). Il est marqué par le symbole suivant. Thermo Fisher Scientific s'est associé avec une ou plusieurs compagnies de recyclage dans chaque état membre de l'union européenne et ce produit devrait être collecté ou recyclé par celles-ci. Davantage d'informations sur la conformité de Thermo Fisher Scientific à ces directives, les recycleurs dans votre pays et les informations sur les produits Thermo Fisher Scientific qui peuvent aider la détection des substances sujettes à la directive RoHS sont disponibles sur <http://www.thermofisher.com/>

France



**Cumplimiento de WEEE.** Se requiere que este producto cumpla con la Directiva 2012/19/EU de Desechos de Equipos Eléctricos y Electrónicos (WEEE) de la Unión Europea. Está marcado con el siguiente símbolo. Thermo Fisher Scientific ha contratado a una o más empresas de reciclaje / eliminación en cada Estado miembro de la UE, y este producto debe desecharse o reciclarse a través de ellos. Para obtener más información sobre el cumplimiento de estas Directivas, los recicladores de su país e información sobre los productos Thermo Scientific que pueden ayudar a detectar sustancias sujetas a la Directiva RoHS, visite [www.thermofisher.com/](http://www.thermofisher.com/)

Spanish



**Section 12**  
Regulatory Compliance



# Appendix A Handling Liquid Nitrogen



**Warning** Contact of liquid nitrogen or cold gas with the skin or eyes may cause serious freezing (frostbite) injury. ▲

**Caution** Handle liquid nitrogen carefully. ▲

The extremely low temperature can freeze human flesh very rapidly. When spilled on a surface the liquid tends to cover it completely and intimately, cooling a large area. The gas issuing from the liquid is also extremely cold. Delicate tissue, such as that of the eyes, can be damaged by an exposure to the cold gas which would be too brief to affect the skin of the hands or face.

**Caution** Never allow any unprotected part of your body to touch objects cooled by liquid nitrogen. ▲

Such objects may stick fast to the skin and tear the flesh when you attempt to free yourself. Use tongs to withdraw objects immersed in the liquid, and handle the object carefully.

**Caution** Wear protective clothing. ▲



Protect your eyes with a face shield or safety goggles (safety glasses without side shields do not give adequate protection). Always wear gloves when handling anything that is, or may have been, in immediate contact with liquid nitrogen. Insulated gloves are recommended, but heavy leather gloves may also be used. The gloves should fit loosely, so that they can be thrown off quickly if liquid should splash into them. When handling liquid in open containers, it is advisable to wear high-top shoes. Trousers (which should be cuffless if possible) should be worn outside the shoes.

## Introduction

The safe handling and use of liquid nitrogen in cryogenic refrigerators and dewar flasks is largely a matter of knowing the potential hazards and using common-sense procedures based on that knowledge. There are two important properties of liquid nitrogen that present potential hazards:

1. It is extremely cold. At atmospheric pressure, liquid nitrogen boils at  $-320^{\circ}\text{F}$  ( $-196^{\circ}\text{C}$ ).
2. Very small amounts of liquid vaporize into large amounts of gas. One liter of liquid nitrogen becomes 24.6 cu. ft. (700l) of gas.

The safety precautions in this booklet must be followed to avoid potential injury or damage which could result from these two characteristics. Do not attempt to handle liquid nitrogen until you read and fully understand the potential hazards, their consequences, and the related safety precautions. Keep this booklet handy for ready reference and review.

**Note** Because argon is an inert gas whose physical properties are very similar to those of nitrogen, precautions and safe practices for the handling and use of liquid argon are the same as those for liquid nitrogen. ▲

### Use only containers designed for low temperature liquids.

Cryogenic containers are specifically designed and made of materials that can withstand the rapid changes and extreme temperature differences encountered in working with liquid nitrogen. Even these special containers should be filled SLOWLY to minimize the internal stresses that occur when any material is cooled. Excessive internal stresses can damage the container.



**Caution** Do not cover or plug the entrance opening of any liquid nitrogen refrigerator or dewar. Do not use any stopper or other device that would interfere with venting of gas. ▲

These cryogenic liquid containers are generally designed to operate with little or no internal pressure. Inadequate venting can result in excessive gas pressure which could damage or burst the container. Use only the loose-fitting necktube core supplied or one of the approved accessories for closing the necktube. Check the unit periodically to be sure that venting is not restricted by accumulated ice or frost.

**Use proper transfer equipment.**

Use a phase separator or special filling funnel to prevent splashing and spilling when transferring liquid nitrogen into or from a dewar or refrigerator. The top of the funnel should be partly covered to reduce splashing. Use only small, easily-handled dewars for pouring liquid. For the larger, heavier containers, use a cryogenic liquid withdrawal device to transfer liquid from one container to another. Be sure to follow instructions supplied with the withdrawal device. When liquid cylinders or other large storage containers are used for filling, follow the instructions supplied with those units and their accessories.

**Do not overfill containers.**

Filling above the bottom of the necktube (or specified maximum level) can result in overflow and spillage of liquid when the necktube core or cover is placed in the opening.

**Never use hollow rods or tubes as dipsticks.**

When a warm tube is inserted into liquid nitrogen, liquid will spout from the top of the tube due to gasification and rapid expansion of liquid inside the tube.



**Warning** Nitrogen gas can cause suffocation without warning! ▲

**Caution** Store and use liquid nitrogen only in a well-ventilated place. ▲

As the liquid evaporates, the resulting gas tends to displace the normal air from the area. In closed areas, excessive amounts of nitrogen gas reduce the concentration of oxygen and can result in asphyxiation. Because nitrogen gas is colorless, odorless and tasteless, it cannot be detected by the human senses and will be breathed as if it were air. Breathing an atmosphere that contains less than 18% oxygen can cause dizziness and quickly result in unconsciousness and death.

**Note** The cloudy vapor that appears when liquid nitrogen is exposed to the air is condensed moisture; not the gas itself. The issuing gas is invisible. ▲

**Never dispose of liquid nitrogen in confined areas or places where others may enter.**

Disposal of liquid nitrogen should be performed outdoors in a safe place. Pour the liquid slowly on gravel or bare earth where it can evaporate without causing damage. Do not pour the liquid on pavement.

## Appendix B Handling Liquid CO<sub>2</sub>



**Warning** High concentrations of CO<sub>2</sub> gas can cause asphyxiation! OSHA Standards specify that employee exposure to carbon dioxide in any eight-hour shift of a 40-hour work week shall not exceed the eight-hour time weighted average of 5000 PPM (0.5% CO<sub>2</sub>). The short term exposure limit for 15 minutes or less is 30,000 PPM (3% CO<sub>2</sub>). Carbon dioxide monitors are recommended for confined areas where concentrations of carbon dioxide gas can accumulate. ▲

**Store and use liquid CO<sub>2</sub> only in a well-ventilated place.**

As the liquid evaporates, the resulting gas tends to displace the normal air from the area. In closed areas, excessive amounts of CO<sub>2</sub> gas reduce the concentration of oxygen and can result in asphyxiation. Because CO<sub>2</sub> gas is colorless, odorless and tasteless, it cannot be detected by the human senses and will be breathed as if it were air. Breathing an atmosphere that contains less than 18% oxygen can cause dizziness and quickly result in unconsciousness and death.

**Note** The cloudy vapor that appears when liquid CO<sub>2</sub> is exposed to the air is condensed moisture; not the gas itself. The issuing gas is invisible. ▲

**Warning** Never dispose of liquid CO<sub>2</sub> in confined areas or places where others may enter. ▲

Disposal of liquid CO<sub>2</sub> should be done outdoors in a safe place. Pour the liquid slowly on gravel or bare earth where it can evaporate without causing damage. Do not pour the liquid on pavement.

## Appendix C First Aid

If a person seems to become dizzy or loses consciousness while working with liquid nitrogen or carbon dioxide, move to a well-ventilated area immediately. If breathing has stopped, apply artificial respiration. If breathing is difficult, give oxygen. Call a physician. Keep warm and at rest.

If exposed to liquid or cold gas, restore tissue to normal body temperature (98.6°F) as rapidly as possible, followed by protection of the injured tissue from further damage and infection. Remove or loosen clothing that may constrict blood circulation to the frozen area. Call a physician. Rapid warming of the affected part is best achieved by using water at 108°F. Under no circumstance should the water be over 112°F, nor should the frozen part be rubbed either before or after rewarming. The patient should neither smoke nor drink alcohol.

**thermoscientific.com**

© 2021 Thermo Fisher Scientific Inc. All rights reserved. All trademarks are the property of Thermo Fisher Scientific and its subsidiaries. Specifications, terms and pricing are subject to change. Not all products are available in all countries. Please consult your local sales representative for details.



**Thermo Fisher Scientific (Asheville) LLC**  
401 Millcreek Road  
Marietta, Ohio 45750  
United States

**Thermo**  
S C I E N T I F I C  
A Thermo Fisher Scientific Brand