

**Thermo Scientific
AquaSensors™ AquaTrace™
Trace DO System
User Guide**



ROSS and the COIL trade dress are trademarks of Thermo Fisher Scientific Inc. U.S. patent 6,793,787.

Alconox® is the registered trademark of Alconox, Inc, Glenview, NY.

Dawn® is the registered trademark of Procter & Gamble, Cincinnati, OH.

Teflon® is a registered trademark of DuPont.

CANopen® is a registered trademark of the CAN in Automation User's Group.

DeviceNet® is a trademark of Open DeviceNet Vendor Association, Inc.

Modbus® is a registered trademark of Modbus Organization, Inc.

Preface

This instruction manual serves to explain the use of the Thermo Scientific AquaTrace™ Trace Dissolved Oxygen Measurement System and is written to cover as many applications as possible. Please do not hesitate to contact Thermo Fisher Scientific or an authorized representative with questions or concerns.

The information presented in this instruction manual is subject to change without notice as improvements are made, and does not represent any commitment whatsoever on the part of Thermo Fisher Scientific.

Thermo Fisher Scientific cannot accept any responsibility for damage or malfunction of the sensor due to improper use.

Contact Information

To contact Thermo Scientific AquaSensors Technical Support:

Within the United States call 1.800.225.1480 or fax 978-232-6015.

Outside the United States call 978.232.6000 or fax 978.232.6031.

In Europe, the Middle East, Asia, and Africa, contact your local authorized dealer.

Visit us on the web at: www.thermofisher.com/processwater

Safety Information



The Thermo Scientific AquaSensors AquaTrace™ Dissolved Oxygen Measurement System shall be installed and operated only in the manner specified. Only a skilled, trained or authorized person should carry out installation, setup and operation of the sensor system.

Before using the system, make sure that is connected as specified. Failure to do so may result in permanent damage to the system of its components.

Protection against electric shock will be achieved only by observance of the corresponding installation rules.

Table of Contents

1. INTRODUCTION	4
1.1 General Information	4
1.2 Intended use	4
1.3 Safety Instructions	5
1.4 Removal from Service / Correct Disposal of the Trace DO Measurement System	5
2. PRODUCT DESCRIPTION	6
2.1 System Description	6
2.2 Sensor Description	7
2.3 AV38 Remote Display	9
3. INSTALLATION	10
3.1 System Mounting and Installation	10
3.2 Wiring	12
4. SYSTEM OPERATION AND MAINTENANCE	13
4.1 Sensor Startup	13
4.2 System Shut-Down and Sensor Storage	14
4.3 System Maintenance – Cleaning	14
4.4 Sensor Maintenance – Replacing the Membrane Cap and Electrolyte	15
4.5 Sensor Maintenance – Trace DO System Troubleshooting	16
5. SENSOR CALIBRATION	17
5.1 Temperature Calibration	17
5.2 Dissolved Oxygen Calibration – Air Calibration	19
5.3 Dissolved Oxygen Calibration – Zero Calibration	22
5.4 Dissolved Oxygen Calibration – 1-Point Calibration	23
6. AquaTrace System Order Matrix and Accessories	25
6.1 AquaTrace Trace DO System Configuration Options	25
6.2 AquaTrace System Replacement Electrolyte and Membrane Caps	25
6.3 AquaTrace Trace DO Specifications	26
7. Terms and Conditions	27
7.2 Terms and Conditions of Sale Continued	28

1. INTRODUCTION

1.1 General Information

The product is designed for continuous use in industrial process applications and complies with safety regulations currently in force. Improper use could lead to hazards for the user or a third-party, and/or adverse effects to the plant or other equipment.

Thermo Fisher Scientific does not accept any liability for damage that may arise if information in this manual is not followed. Therefore, the operating instructions and specifications must be read and understood by all persons involved in installation and operation of this equipment.

This manual identifies safety instructions and additional information by means of the following symbols:



This symbol draws attention to **safety instructions and warnings of potential danger**, which if neglected, could result in injury to persons and/or damage to property.



This symbol identifies **additional information and instructions**, which if neglected, could lead to inefficient operation and possible loss of production.

It is recommended that this manual be made accessible to everyone who may need it as a reference. Please contact Thermo Fisher Scientific or an authorized representative with any questions.

1.2 Intended use

The Thermo Scientific AquaSensors AquaTrace DO System is capable of continuous monitoring of dissolved oxygen in applications between 20 ppm and 0.1 ppb. The system also measures water temperature.

Any other use, or use not mentioned here, that is incompatible with the technical specifications is deemed inappropriate. The operator is solely responsible for any damage arising from such use.

Other prerequisites for appropriate use include:

- Observing the instructions, notes and requirements set out in this instruction manual.
- Observing all local safety regulations.

- Observing all warnings and cautions in the documentation regarding all products used in this measurement system, including the sensor, mounting hardware, AV38 electronics and cabling.
- Observing the prescribed environmental and operational conditions.
- Observing chemical compatibility with all wetted materials.

1.3 Safety Instructions

The Trace DO Measurement System should be installed and operated only by personnel familiar with the sensor and qualified for such work.



A defective Trace DO Measurement System should be returned to Thermo Fisher Scientific for repair or replacement. Contact Thermo Fisher Scientific to obtain a Return Material Authorization (RMA) number.

No modifications to the Trace DO Measurement System are allowed. The manufacturer/supplier accepts no responsibility for damage caused by unauthorized modifications. The risk is borne entirely by the user.

1.4 Removal from Service / Correct Disposal of the Trace DO Measurement System

Removal from Service

1. Shut off the process sample connection to the AquaTrace system.
2. Disconnect the power supply to the AquaTrace system.
3. Disconnect any cable wiring from the AquaTrace analyzer's outputs.
4. Disconnect the process connections to the AquaTrace system.
5. Remove the sensor from the flow chamber.
6. Rinse the sensor head with clean water and replace the storage cap on the end of the AquaTrace sensor.
7. Rinse the inside of the flow chamber with clean water and allow it to dry.
8. Replace the sensor inside the flow chamber.

Correct Disposal of Unit

- When the Trace DO Measurement System is taken out of service, observe the local environmental regulations for correct disposal.

2. PRODUCT DESCRIPTION

2.1 System Description

The Thermo Scientific AquaSensors AquaTrace DO system is used for continuous measurement of dissolved oxygen. The system is capable of measuring dissolved oxygen where the oxygen concentration is below 20 ppm but it is intended for service in applications below 1000 ppb. The system also measures the sample temperature across its rated range.

The AquaTrace DO is a complete system that includes all components necessary for the low-level oxygen measurement. The system consists of a low-level oxygen sensor head, a DataStick sensor body with a communication adapter, and a sample chamber mounted to a back panel for easy installation. The system includes an AV38 remote display either mounted to the back panel or ready for mounting at a remote location depending on how the system is configured.

The sample chamber secures the sensor in the process. It directs the sample flow onto the sensing face of the probe and directs the outlet flow away from the sensor tip while also eliminating entrapped bubbles. This improves the sensor's response to changing process conditions and maximizes the accuracy of the dissolved oxygen measurement. The sample chamber uses a union-style locking ring to secure the sensor, allowing the sensor to be inserted and removed without twisting the sensor cable.

The AquaTrace system includes an AV38 local display that allows the operator to interface with the sensor. The AV38 allows the operator to display the system's measurement values, to calibrate the sensor, and to configure the sensor's various measurement options. The AV38 can be configured with relays and analog outputs for use in control systems and can include host communications for network communications using one of several standard protocols. The images below indicate panel dimensions.

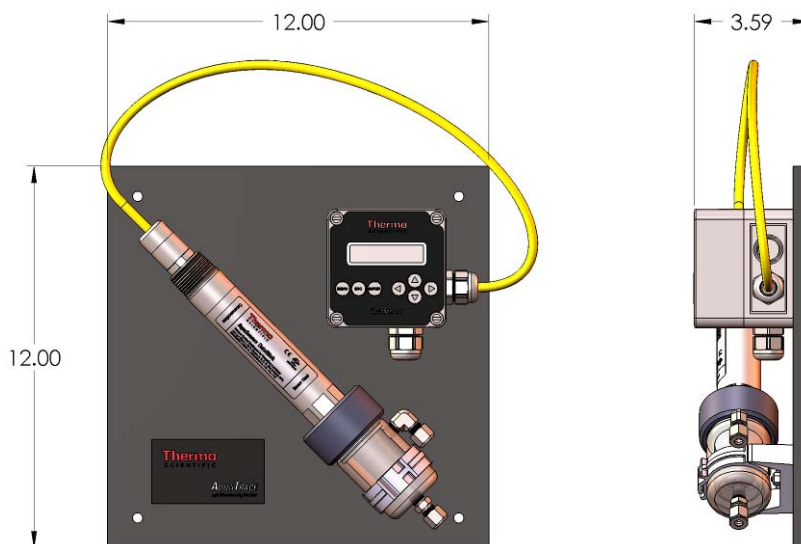

AquaTrace Trace DO Measurement System

System Specifications:

Wetted Materials.....	Sample Chamber –Acrylic, Viton, 316 Stainless Steel Sensor – PEEK, 316 Stainless Steel, Viton, FEP
Operating Temperature	5 to 50°C (40 to 120°F)
Maximum Pressure.....	60 psi supply
Sample Flow Rate	50 to 400 mL/min (0.8 to 6.3 gal/hr)
Measuring Range	0.1 ppb to 20 ppm
Resolution	0.1 ppb / 0.01 ppm

2.2 Sensor Description

The Thermo Scientific AquaSensors Trace DO sensor uses the amperometric measurement technique to maximize lifetime in continuous industrial applications. The sensor is easily maintained and reconditioned by replacing the convenient pre-tensioned membrane cap and electrolyte. The sensor includes an integral temperature element that is closely coupled to the process sample to insure an accurate measurement.

The sensor head is pre-calibrated for span and the zero is factor set. The integral electronics in the sensor head retain calibration data and the sensor does not require a new calibration when the system is installed, although it is recommended that a sample calibration be performed at the typical service range to maximize accuracy during operation.

The Trace DO sensor uses the DataStick sensor system. The DataStick consists of a standard sensor body, an interchangeable sensor head, and a communications adapter. The sensor head threads into the front of the DataStick sensor body. The DataStick body's internal electronics work with the sensor head to calculate the measurement values. The communications adapter assembles into the back end of the DataStick body and transmits the measurement data using one of several standard communication protocols.

The sensor is designed for continuous use and has 1-inch NPT mounting threads for installation into the sample chamber adapter. The parts of the sensor system are shown here:

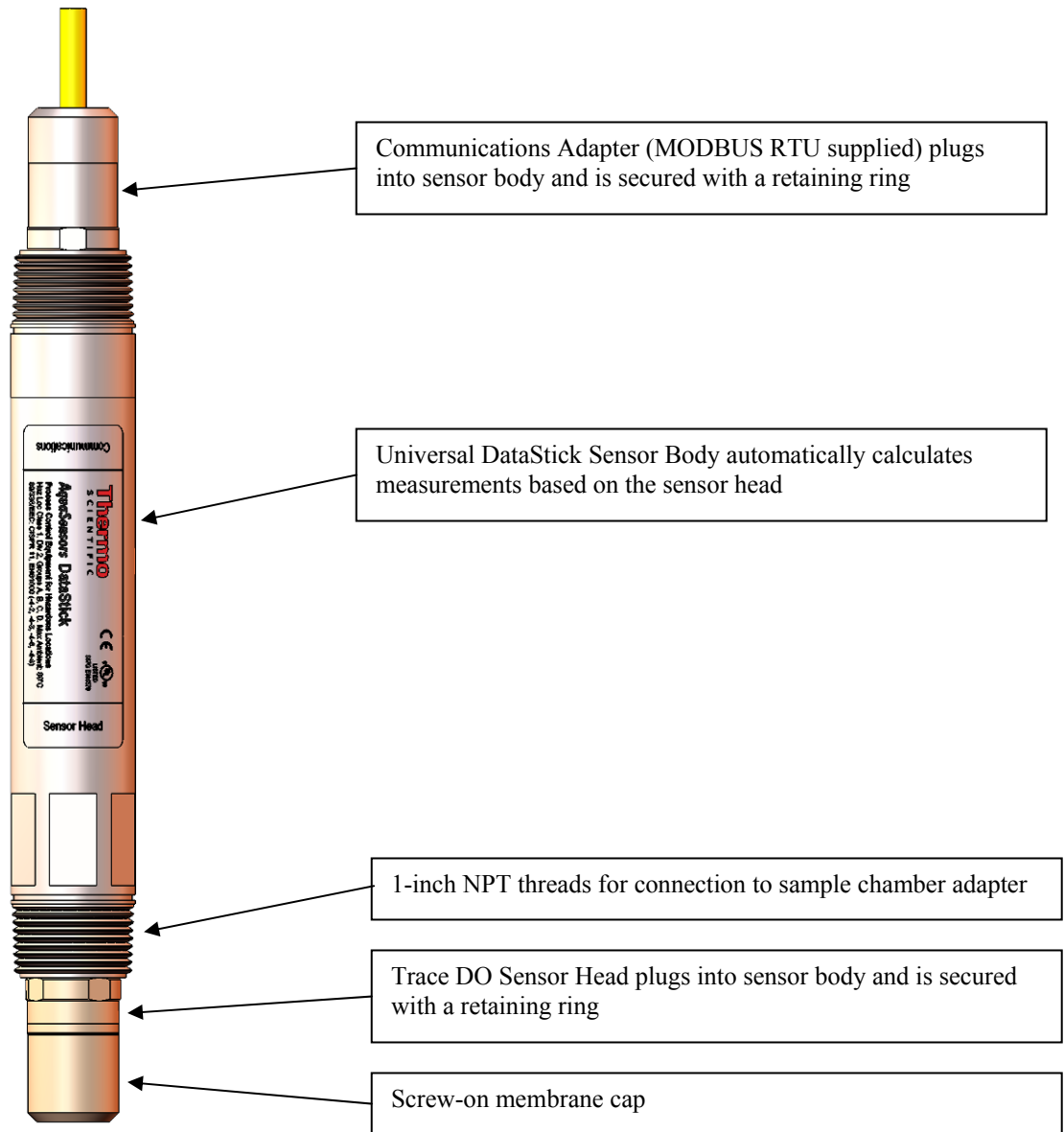

Sensor Highlights:

- 0.1 ppb to 20 ppm Measurement Ranges
- Calibration stored in Sensor (Does not require recalibration after connection to Analyzer/Controller)
- 0.1 ppb Resolution
- Fast Response
- Simple membrane and electrolyte replacement
- Provides measurement, calibration, configuration and diagnostic functions without Analyzer/Controller
- Works with AV38 for local display, current output data reporting, and relay control

- Temperature measurement included
- Can be connected to MODBUS®, DeviceNET®, Ethernet, USB, RS-232 and CANopen® networks.

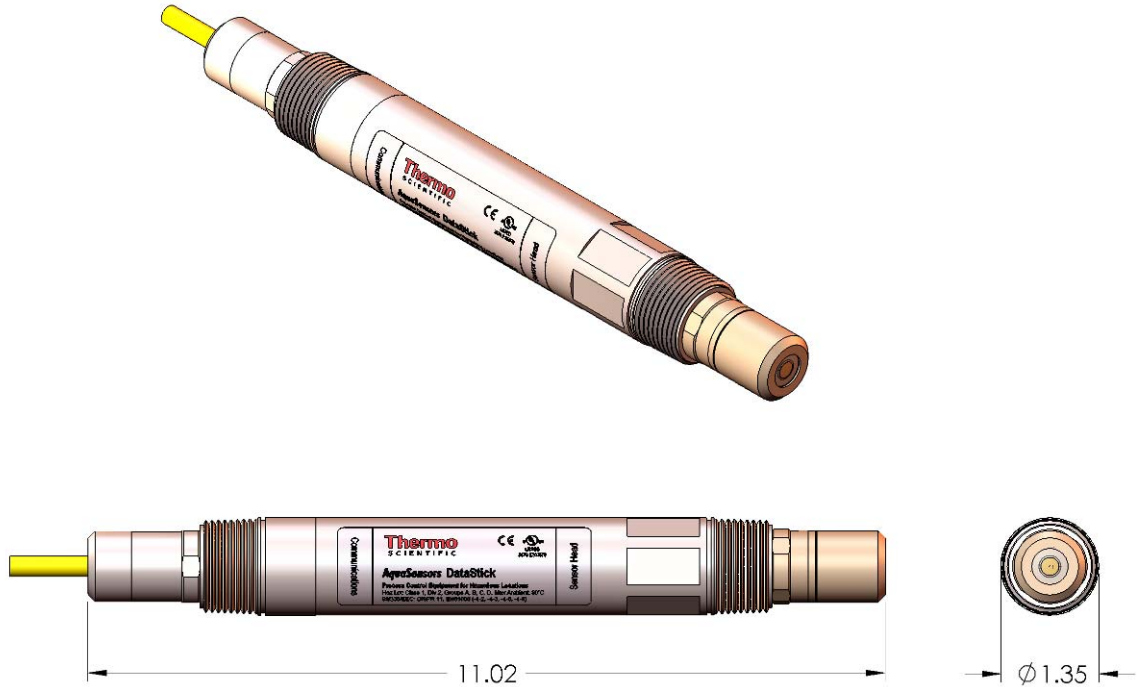

2.3 AV38 Remote Display

For detailed information on configuration of AV38 current outputs, relays, host communications, please refer to the AV38 manual. This manual will describe basic calibration, configuration and dissolved oxygen compensation functions directly related to dissolved oxygen measurements

The AV38 is a universal display interface for DataStick sensor systems that includes dissolved oxygen measurement. The enclosure has ¼ DIN dimensions for easy mounting and is rated NEMA 4X for outdoor use. It uses a liquid crystal display (LCD) with a high contrast backlight for best readability and is powered with 24 volts DC or optionally with line power (90 VAC to 240 VAC).



The AV38 automatically recognizes the type of DataStick connected to the system and provides the appropriate calibration, configuration and diagnostic menus. It has options for two 4-20 current outputs, two alarm/control/wash relays and network communications to a host computer. In addition, the AV38 can address up to 247 DataStick sensors.

DataStick sensors connected to the AV38 communicate via MODBUS RTU. As such, the AV38 can be used to select any two of the DataStick sensors on the bus for display, current output reporting and relay alarms by selecting the desired station addresses. When there is no DataStick sensor connected at the selected network address, the measure screen will indicate "DataStick Absent".

There are seven keys for menu navigation. The MENU key is used to toggle between the menu and the measure screen. Pressing the Menu key provides options for calibration, configuration, communications, outputs and relays. Refer to the AV38 Manual for Details.

3. INSTALLATION

3.1 System Mounting and Installation

The AquaTrace measurement system is mounted on a 12 inch X 12 inch panel with four ¼" mounting holes. Use ¼ inch bolts with washers to mount the panel to a wall.

The sample supply is connected to the fitting at the bottom of the flow chamber. The sample supply should be regulated to control pressure and flow. The sample pressure should not exceed 60 psi. The sample flow rate should be regulated between 50 mL/min and 400 mL/min. The sensor will operate properly across this range, however rapid variations in flow can cause temporary measurement fluctuations. To insure a stable measurement, the sample supply should be regulated to provide a consistent flow rate to the sample chamber.

The outlet fitting on the sample chamber must be connected to a vented drain. Excessive tubing length or pipe restrictions that result in back pressure to the outlet are not allowed.

The inlet and outlet port on the sample chamber are supplied with compression fittings for use with ¼ inch OD tubing. When the inlet and outlet are to be directly plumbed, remove the compression fittings and connect to the flow chamber with 1/8 inch NPT fittings

Note that the tubing and plumbing used to install the AquaTrace system must not be gas measuring the process. Verify that all plumbing permeable. Stainless steel, Kynar PVDF and polypropylene are relatively impermeable to oxygen. Other materials such as silicone are gas permeable and allow oxygen contamination that will prevent the system from accurately components are suitable for use with a low oxygen process.

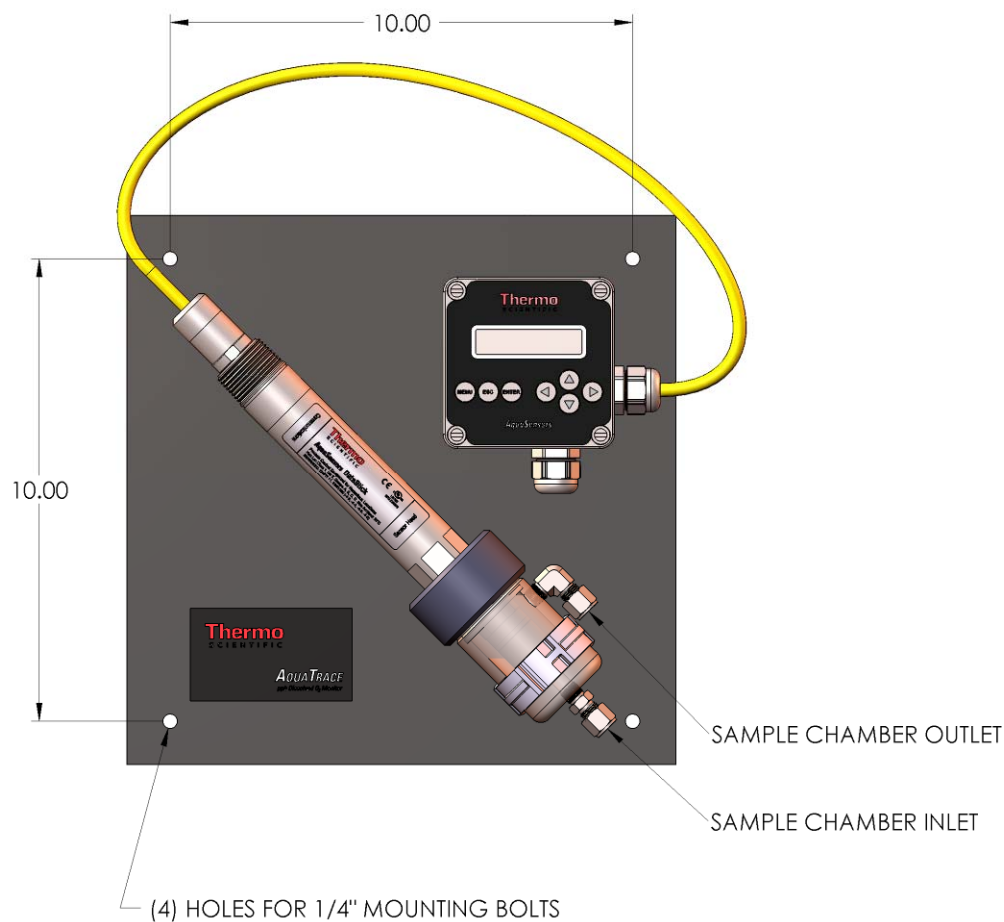

Tools and Equipment required for installation:

- ½ inch drill with drill bits for appropriate wall anchor
- Four ¼ inch diameter bolts – 1.5 inches long
- Four ¼ inch flat washers
- Adjustable wrench
- ¼ inch tubing
- Pressure / flow regulating valve
- Shut-off valve
- Standard screw driver

Panel Mounting Instructions:

1. Place the 12 inch x 12 inch pane on the wall where it is to be mounted and mark the placement of the upper left hole.
2. Drill a mounting hole for the upper left corner with a masonry drill bit and install a wall anchor.
3. Mount the AquaTrace panel with the upper left mounting bolt.
4. Using a level, rotate the panel until the top edge is level, then mark the remaining three mounting holes.
5. Rotate the AquaTrace panel out of the way, drill the three mounting holes and install wall anchors.
6. Secure the panel with all four bolts and washers and tighten.

General System Installation Instructions:

1. Connect the sample chamber outlet to a vented drain.
2. Connect the process supply to the sample chamber inlet. The sample supply flow rate must be between 50 and 400 mL/min and the sample pressure must not exceed 60 psi. Use an appropriate flow or pressure valve to obtain consistent flow.
3. Connect the appropriate power to the AV38 Remote Display. Route the power line through the cord grip in the AV38 housing and connect the leads to the appropriate terminals. Follow local codes and regulations governing the power supply. Refer to the AV38 User Guide for details on connecting power.
4. The Trace DO sensor is supplied with the sensor cable connected to the AV38 Remote Display. If the sensor has been disconnected for any reason, reconnect it to the appropriate terminals. Follow the connection guide on the AV38 terminals or refer to the sensor set-up section in this user guide.
5. Unscrew the sample chamber retaining ring and remove the Trace DO sensor.
6. Carefully remove the protective cap from the sensor head. Refer to Section 4.1 of this user guide, the sensor set-up, for detailed information on handling and setting up the sensor.
7. Insert the sensor back into the sample chamber and tighten the retaining ring.
8. Open process flow to the sample chamber. Observe the chamber and verify that it purges any trapped gas and drains properly.
9. Power up the AV38 Remote Display.
10. The AV38 Remote Display includes optional host communications, relays and analog outputs that can be used with various control systems. Refer to the AV38 user guide for detailed instructions to configure these options.

3.2 Wiring

A DataStick sensor can be configured to operate using one of several standard communications protocols. A label at the end of the sensor cable identifies the specific communication protocol used by that sensor. The sensor supplied with the AquaTrace DO system uses the MODBUS RTU protocol enabling it to communicate with the AV38 Remote Display.

There are two different methods to make the electrical connection between the Trace DO sensor and the AV38 Remote Display. The sensor can be wired directly to the Remote Display. In cases where the AV38 Remote Display is mounted more than 30 feet from the AquaTrace panel, the sensor can be connected using an interconnect cable and a junction box. The system is supplied with the sensor directly wired to the Remote Display.

Direct Connection:

1. Insert the sensor cable through a watertight cord grip into the AV38 Remote Display. Conduit holes are located on the base of the AV38 for this purpose.
2. Connect the sensor wires to the AV38 as shown on the AV38 wiring chart.

Indirect Connection (using extension cable and a junction box):

1. Insert the sensor cable and interconnect cable through watertight cord grips into the junction box.

2. Connect the sensor cable lead wires and the interconnect cable lead wires to the terminal strip in the junction box.
3. Insert the other end of the interconnect cable through a watertight cord grip into the AV38 Remote Display. Conduit holes are located on the base of the AV38 for this purpose.
4. Connect the interconnect lead wires to the AV38 as shown on the AV38 wiring chart

	Be sure that the wire colors of the sensor cable match those of the interconnect cable.
---	---

	Route the interconnect cable through metal conduit to minimize electrical noise that may interfere with the sensor signal.
---	--

4. SYSTEM OPERATION AND MAINTENANCE

4.1 Sensor Startup

The sensor is shipped with a protective cap on the sensor head to keep the membrane wet and protect it from damage. The cap should remain on the sensor head until the sensor is installed in the sample. Remove the cap by pulling it straight off down the side of the sensor. Be careful not to damage the sensor membrane. Save the protective cap and use it to keep the membrane moist whenever the sensor is removed from service.

The membrane cap is screwed onto the front of the sensor and care should be taken not to unscrew it. The cap contains dissolved oxygen electrolyte that will spill out if the cap is removed.

The sensor has been charged and tested prior to shipment. However, it requires time to stabilize when it is initially installed. Depending on the oxygen level of the process, the sensor may need to run for up to 12 hours to stabilize after installation.

The sensor has been calibrated for span and offset prior to shipment. The span has been set using an air calibration at approximately 8 ppm. The operator can redo either of these calibrations, although care must be taken, particularly with the zero calibration, to insure accurate results. For maximum accuracy it is recommended the operator perform a 1-point calibration at the high end of the application range. This will update the span and optimize the sensor for the particular process application. The temperature measurement can also be calibrated with a sample calibration. If the temperature measurement requires calibration, it is advantageous to update it prior to calibrating the dissolved oxygen measurement because the DO reading is temperature compensated. See Section 5 for instructions on performing the various calibrations.

4.2 System Shut-Down and Sensor Storage

The sensor membrane must be kept wetted at all times. The sensor is shipped with a protective cover over the membrane cap. This should be kept on the sensor until it is put into service. If the sensor is going to be removed from service for any length of time, it should be stored as follows:

1. Rinse the sensor with clean water.
2. Clean the sensor head as necessary per the cleaning procedure in Section 4.3 of this user guide.
3. Fill the protective vinyl cap with clean water.
4. Secure the protective cap on the end of the sensor.

If the entire system will be taken out of service for any prolonged period, prepare it for storage as follows:

1. Shut off process flow to the sample chamber.
2. Remove the Trace DO sensor from the sample chamber.
3. Clean and cap the Trace DO sensor as noted above.
4. Drain the sample chamber and rinse it with clean water. If necessary, clean any deposits as noted below.
5. Dry the interior of the sample chamber.
6. Place the capped Trace DO sensor back in the flow chamber for storage.

4.3 System Maintenance – Cleaning

In order to maintain an accurate measurement value, the sensor will need occasional maintenance. The maintenance interval will be dictated by the process in which it is installed. The harsher the process, the more often the sensor will require maintenance. Regular maintenance will yield a longer sensor life.

Clean the sensor as follows:

1. Remove the sensor from the sample chamber.
2. Rinse or spray the sensor with warm water to remove any heavy deposits.
3. If fine deposits are still present, soak the sensor in a container of warm detergent water for one hour. Do not use detergents that contain oily skin softeners like aloe or lanolin that can coat the membrane. Alconox® and Dawn® dishwashing liquid work well.
4. Rinse the sensor with clean warm water.
5. If deposits are still present on the membrane, repeat the soaking and rinsing steps.

Before returning the sensor to service, allow it to soak in water at ambient temperature for about an hour to stabilize the DO membrane.

After cleaning the sensor, perform an air calibration per the instructions in Section 5.

Reinstall the sensor in the sample chamber and perform a 1-point calibration to adjust the sensor span as necessary. See section 5 for instructions on performing a 1-point calibration.

The sample chamber should be kept clean as well. It should be inspected regularly for the formation of deposits or films. Clean the inside of the sample chamber when required as follows:

1. Shut off process flow to the sample chamber.
2. Remove the sensor from the sample chamber.
3. Drain the sample chamber.
4. Rinse the chamber out with a soft brush and clean water. If necessary, use a mild detergent such as Alconox or Dawn dishwashing liquid. Do not use chemical solvents or abrasive cleaners on the sample chamber.
5. Rinse the chamber with clean water.
6. Insert the Trace DO sensor back into the flow chamber and secure it with the retaining ring.
7. Resume process flow through the sample chamber.

4.4 Sensor Maintenance – Replacing the Membrane Cap and Electrolyte

If the sensor head has been cleaned and the sensor will still not calibrate properly, replace the membrane cap and electrolyte solution per the following procedure:

1. Hold the sensor firmly with the electrode tip facing down. Remove the existing membrane cap by turning it counterclockwise. Dispose of the old membrane cap and electrolyte using an approved method.
2. Fill the new membrane cap with fresh DO electrolyte and gently agitate it to remove trapped bubbles.
3. Place the sensor head into the new membrane cap
4. Slowly screw the new membrane cap clockwise onto the sensor head until secure. Place a finger tip on the outside surface of the membrane and apply slight pressure to support it as you thread the cap onto the sensor. Excess electrolyte will be expelled from the cap as you assemble it.



Install slowly! Screwing the membrane cap on quickly may cause pressurization of the membrane.



Do not over tighten!
Maximum torque: 10 lbs-in (1.130 N-m)

5. Before returning the sensor to service, allow it to soak in water at ambient temperature for about an hour to stabilize the DO membrane.
6. After soaking the sensor, perform an air calibration per the instructions in Section 5.
7. Reinstall the sensor in the sample chamber and perform a 1-point calibration to adjust the sensor span

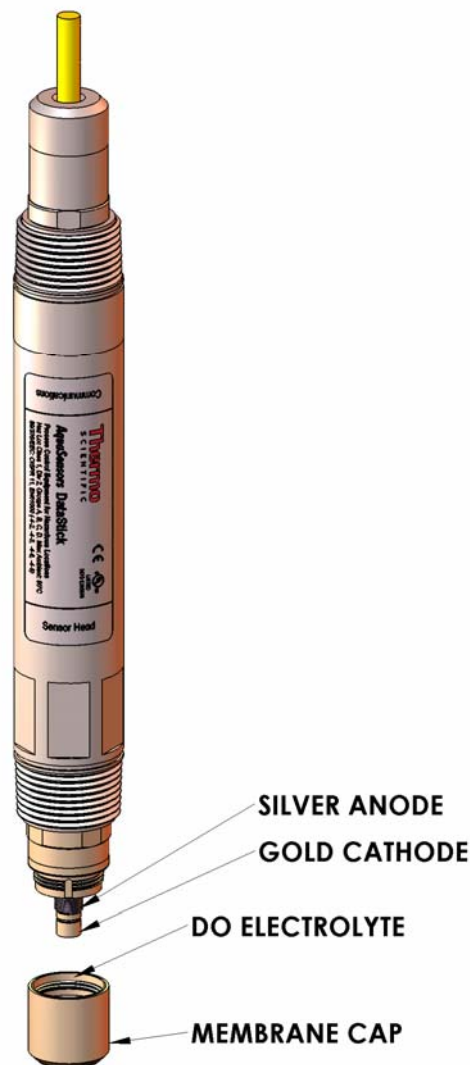

as necessary. See Section 5 for instructions on performing a 1-point calibration.

4.5 Sensor Maintenance – Trace DO System Troubleshooting

If the sensor is not providing reasonable signals to the Remote Display, check the following:

- Verify that process is flowing through the sample chamber. If flow is blocked, the sensor will consume the available oxygen in the sample chamber and display a 0 ppb dissolved oxygen measurement.
- Inspect the integrity of the sensor membrane. If the membrane is torn or punctured, replace it with a new membrane cap and fresh electrolyte.
- Inspect the sensor cable for damage. Any cuts or kinks in the outer jacket may damage signal connections.
- Inspect the terminal block connections to be sure the wires are not corroded or loose.
- Make sure all sensor wires are connected properly to the AV38 Remote Display terminal block.
- Immerse the sensor in a solution of known dissolved oxygen value and check the displayed measurement.
- Verify that the AV38 Remote Display electronics are working correctly by connecting it to another sensor if available.



Note: Any new sensor that has been in storage for more than a few days should be soaked in clean water for at least 30 minutes before reviewing measurement performance.



Note: The membrane of any DO sensor in storage must be kept moist at all times. The protective cap should be filled with clean water and placed securely over the sensor head.

5. SENSOR CALIBRATION

5.1 Temperature Calibration

The AquaTrace system's temperature measurement can be recalibrated using a 1-point sample calibration. Use the following procedure to calibrate the temperature measurement:

1. Enter the calibration menu on the AV38 Remote Display (see the AV38 user guide for detailed information on the various menus in the user interface).
2. Press the ENTER key from the TEMPERATURE calibration menu to initiate the calibration process. When the temperature calibration procedure is started, the analog output is placed into hold mode. The user is prompted to prepare the sensor. The sensor value is dynamically updated during this step.

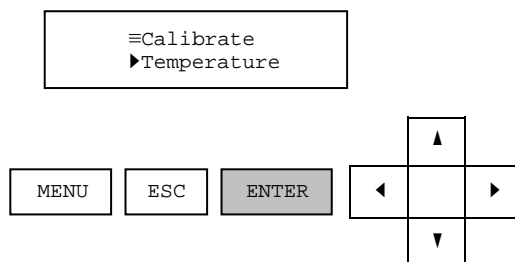

3. Remove the Trace DO sensor from sample chamber.
4. Place the Trace DO sensor in a beaker filled with clean water at the desired calibration temperature.
5. Allow the sensor to stabilize in the calibration bath. The time required to stabilize will vary based on the temperature difference between the process sample and the calibration bath. If the two do not vary significantly, the temperature measurement should stabilize within five minutes. If the variation is significant it may take up to fifteen minutes for the temperature measurement to stabilize sufficiently for an accurate calibration.
6. Use a known reference sensor to determine the actual temperature of the calibration bath.
7. When the sensor is ready, press the ENTER key is pressed and the user is presented with a calibration value for editing.

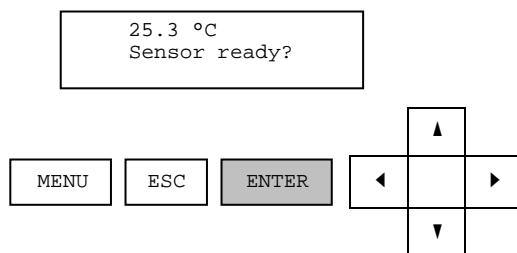

8. The AV38 will display the calibration value for editing. Use the arrow keys to edit the temperature value to the known value of the calibration bath. When the value is correct, press the ENTER key to continue.

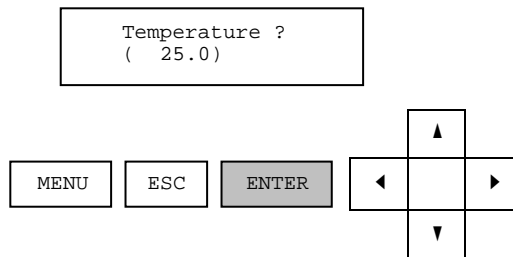

9. The AV38 will calibrate the temperature sensor to match the value entered. During this time, the calibration procedure can be aborted by pressing the ESC key.

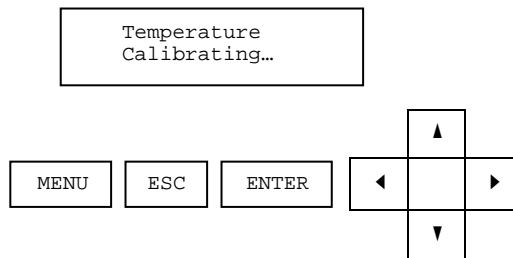

10. After the calibration point has been stored, the AV38 will prompt the user to confirm that the calibration procedure has been successful. Press the ENTER key to accept and continue.

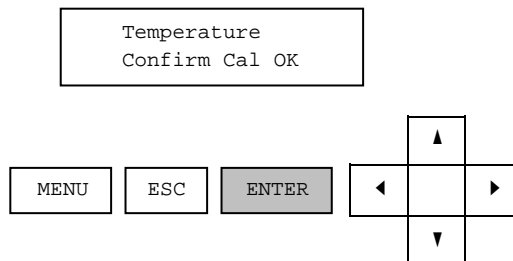

11. When the enter key is pressed, the analog output is placed into active mode and the monitoring of sensor and temperature values is resumed. This successfully completes the temperature calibration procedure.
12. If an error occurs during calibration that causes the procedure to fail, the reason for the failure will be shown.

- After the ENTER key is pressed, the AV38 will return to the calibration menu. The user has the option of repeating the procedure if desired. If not, press the ESC key to exit the menus and return to normal operations.

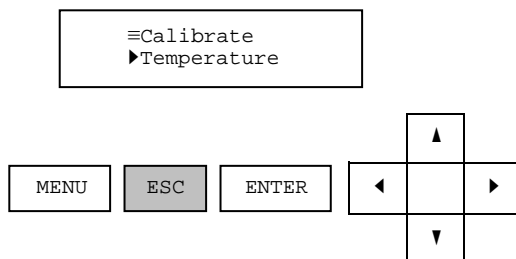

- Place the sensor back into the sample chamber and resume process flow through the AquaTrace system.

5.2 Dissolved Oxygen Calibration – Air Calibration

An air calibration can be performed to update the upper limit of the sensor's span. As supplied, the sensor is factory calibrated and this value is stored in the internal electronics, but the operator can perform this calibration as needed. While it is not necessary, the ambient pressure value in the system should be updated before performing an air calibration. Failure to do so will result in reduced accuracy of the calibration and subsequent span calculations. The ambient pressure setting is updated through the following steps:

- Enter the configuration menu on the AV38 Remote Display (see the AV38 user guide for detailed information on the various menus in the user interface).
- Scroll through the available configuration options until the system displays Pressure. Press the ENTER key to update the ambient pressure.

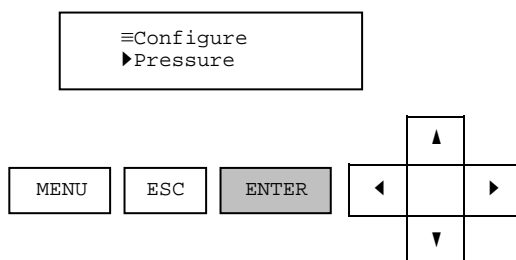

- The AV38 will display the current pressure value for editing. Use the arrow keys to display the current air pressure in mmHg. When the value is correct, press the ENTER key to continue.

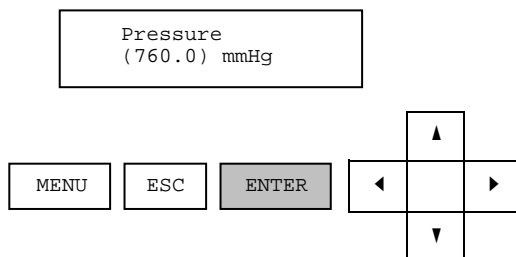

- After the ENTER key is pressed, the AV38 will return to the configuration menu. The user has the option of repeating the procedure if desired. If not, press the ESC key to exit the menus and return to normal operations.

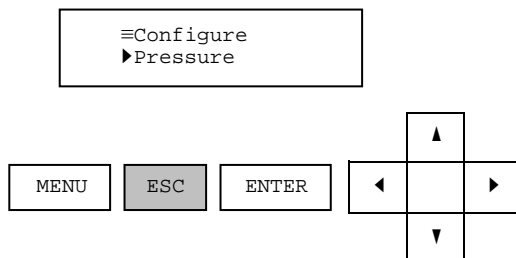

After entering the ambient pressure, use the following procedure to complete the air calibration:

- Enter the calibration menu on the AV38 Remote Display (see the AV38 user guide for detailed information on the various menus in the user interface).
- Press the ENTER key from the AIR calibration menu to initiate the calibration process. When the temperature calibration procedure is started, the analog output is placed into hold mode. The user is prompted to prepare the sensor. The sensor value is dynamically updated during this step.

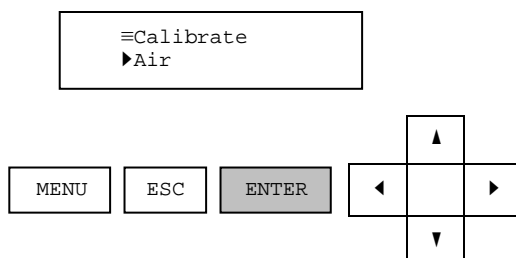

- Remove the Trace DO sensor from sample chamber.
- Rinse the sensor head off with clean water. Shake any excess water off the tip of the sensor.
- Fill a beaker or cup approximately ½ full with clean water. Suspend the sensor over the beaker so that the tip of the sensor sits approximately ¼ to ½ inch above the surface of the water. Allow the sensor to stand approximately fifteen minutes to acclimate and stabilize.
- After the unit has stabilized, press the ENTER key to proceed with the calculation.

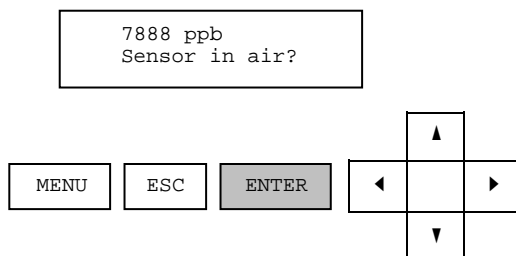

- The AV38 will update the span calibration in the sensor per the calculated value for saturated air using the recorded air pressure and measured temperature. During this time, the calibration procedure can be aborted by pressing the ESC key.

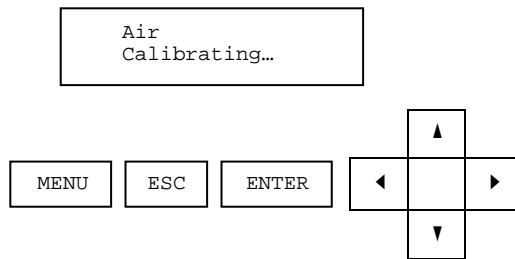

- If an error occurs during calibration that causes the procedure to fail, the reason for the failure will be shown.
- After the calibration point has been stored, the AV38 will return to the calibration menu. The user has the option of repeating the procedure if desired. If not, press the ESC key to exit the menus and return to normal operations.

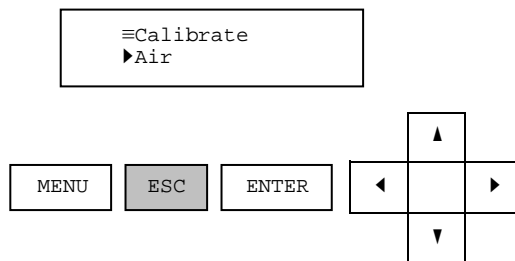

- Place the sensor back into the sample chamber and resume process flow through the AquaTrace system.

5.3 Dissolved Oxygen Calibration – Zero Calibration

A zero calibration can be performed to update the sensor's signal offset. As supplied, the sensor is factory calibrated and this value is stored in the internal electronics, but the operator can perform this calibration as needed. Use the following procedure to perform a zero calibration on the Trace DO sensor.

1. Enter the calibration menu on the AV38 Remote Display (see the AV38 user guide for detailed information on the various menus in the user interface).
2. Press the ENTER key from the ZERO calibration menu to initiate the calibration process. When the temperature calibration procedure is started, the analog output is placed into hold mode. The user is prompted to prepare the sensor. The sensor value is dynamically updated during this step.

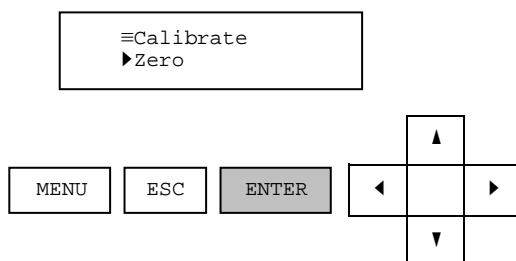

3. Remove the Trace DO sensor from sample chamber.
4. Rinse the sensor head off with clean water. Shake any excess water off the tip of the sensor.
5. Fill a beaker approximately ½ full with zero solution. Zero solution can be prepared by mixing 13.0 grams of sodium sulfite (Na_2SO_3) with 1.0L of deionized water. Observe all safety requirements when mixing and working with the zero solution. Suspend the sensor over the beaker with the tip of the sensor sits immersed at least one-inch deep in the zero solution. Allow the sensor to acclimate and stabilize. In order to reach a stable zero it may be necessary to allow the sensor to stand for up to twelve hours depending on the oxygen level in the sensor prior to the calibration.
6. After the unit has stabilized press the ENTER key to proceed with the calculation.

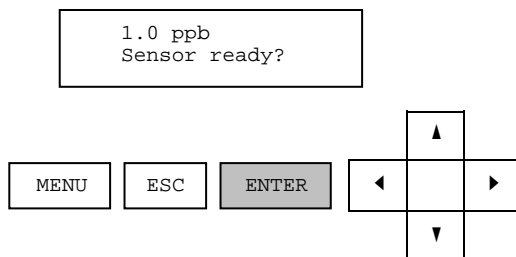

- The AV38 will update the zero calibration in the sensor based on the current measurement. During this time, the calibration procedure can be aborted by pressing the ESC key.

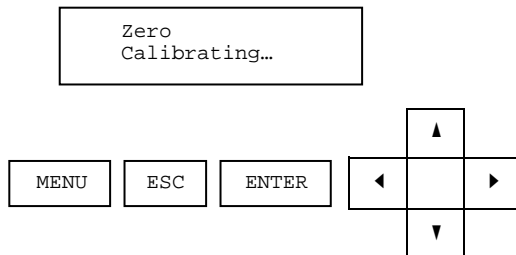

- If an error occurs during calibration that causes the procedure to fail, the reason for the failure will be shown.
- After the calibration point has been stored, the AV38 will return to the calibration menu. The user has the option of repeating the procedure if desired. If not, press the ESC key to exit the menus and return to normal operations.

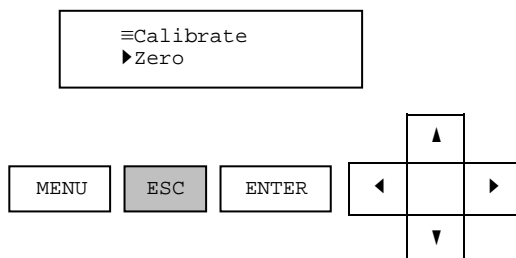

- Place the sensor back into the sample chamber and resume process flow through the AquaTrace system.

5.4 Dissolved Oxygen Calibration – 1-Point Calibration

A 1-point calibration can be performed to update the sensor's span. As supplied, the sensor is factory calibrated using an air calibration and this value is stored in the internal electronics. Performing a 1-point calibration at the upper limit of the specific process will improve the measurement accuracy of low range readings. Use the following procedure to perform a zero calibration on the Trace DO sensor.

- Enter the calibration menu on the AV38 Remote Display (see the AV38 user guide for detailed information on the various menus in the user interface).
- Press the ENTER key from the 1-Point Sample calibration menu to initiate the calibration process. When the temperature calibration procedure is started, the analog output is placed into hold mode. The user is prompted to prepare the sensor. The sensor value is dynamically updated during this step.

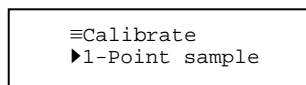

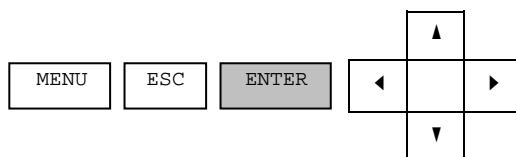

3. Determine the DO level of the current process sample using laboratory methods.

4. Press the ENTER key to proceed with the calculation.

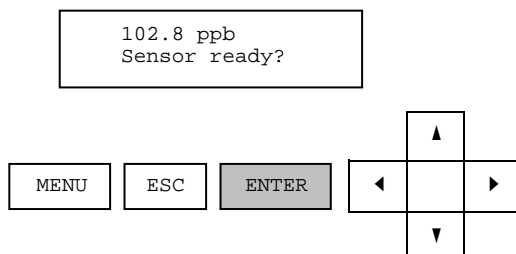

5. The AV38 will display the current DO value for editing. Use the arrow keys to display the actual value as determined by laboratory methods. When the value is correct, press the ENTER key to continue.

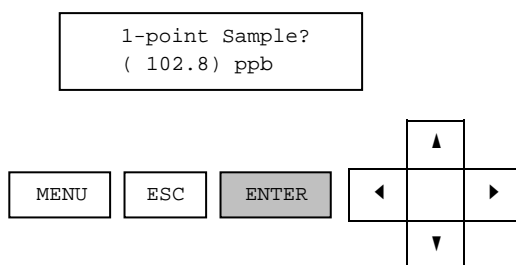

6. The AV38 will update the span calibration in the sensor based on the current measurement. During this time, the calibration procedure can be aborted by pressing the ESC key.

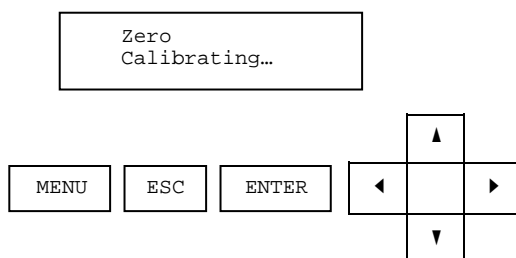

7. If an error occurs during calibration that causes the procedure to fail, the reason for the failure will be shown.

8. After the calibration point has been stored, the AV38 will return to the calibration menu. The user has the option of repeating the procedure if desired. If not, press the ESC key to exit the menus and return to normal operations.

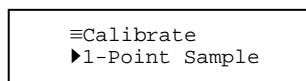

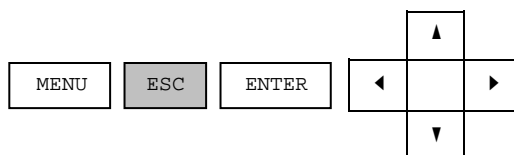

6. AquaTrace System Order Matrix and Accessories

6.1 AquaTrace Trace DO System Configuration Options

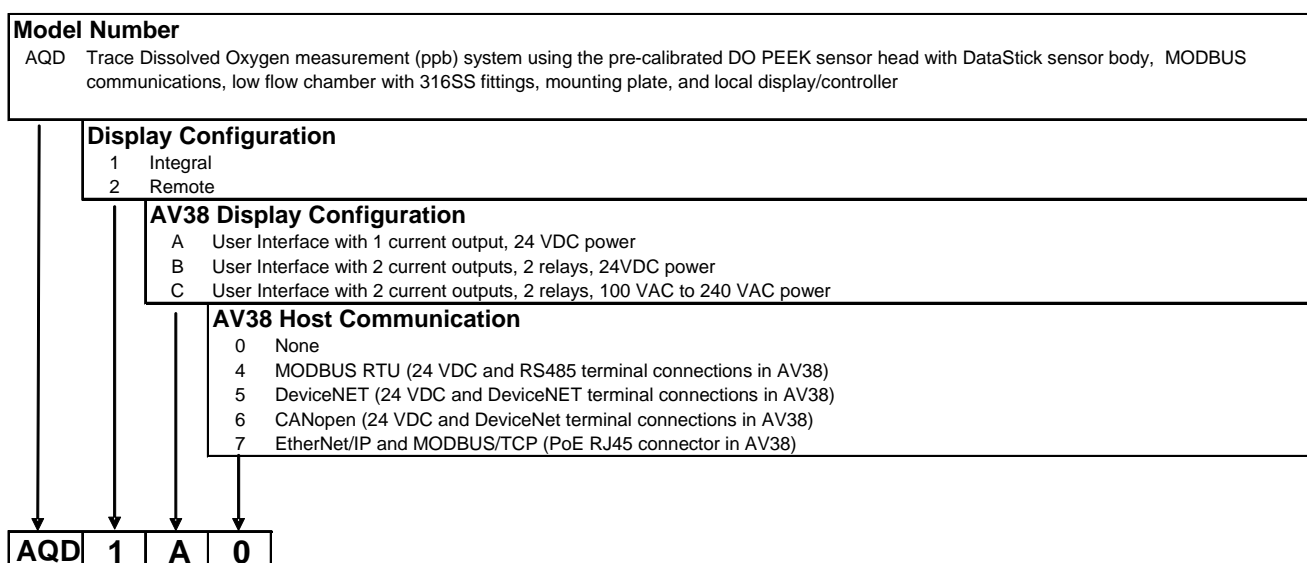

6.2 AquaTrace System Replacement Electrolyte and Membrane Caps

Product	Description	Part Number
PPB Electrolyte	Trace DO Electrolyte solutions – 60mL bottle	080514
PPB Membrane Cap	Replacement membrane cap with pre-stretched membrane	DMR18
Protective Cap	To keep stored membrane wet when stored.	SBC01

6.3 AquaTrace Trace DO Specifications

Specification	Performance
DO Measurement Range	0.1 ppb to 20 ppm
Low Range (below 20ppb) DO Measurement Accuracy	+/-1 ppb or +/-2% of reading (whichever is greater)
High Range DO Measurement Accuracy	+/-5% of reading
DO Measurement Response	<2 hours to 10 ppb
DO Measurement Drift	4% max over 60 days
Temperature Element	PT 1000 RTD
Temp Measurement Resolution	0.1 C
Temperature Measurement Response	<475 sec for 90% of change for +/- 50C change
Temperature Msmt Repeatability	+/- 0.5C
Electrolyte Life	2 months (appx)
Shelf Life	6 months (may require electrolyte replacement after extended storage)

Environmental	
Service Pressure	0- 60 psig
Service Temperature	5 C - 50 C
Storage Temperature	0 C - 60 C
System Process Flow Rate:	50 - 400 mL/min

Features	
Sensor Mounting Threads	1" NPT threads at back of sensor 1" NPT threads at front of sensor
Process Connections	1/4" tube fittings for process inlet and outlet
Sensor Wetted Materials	316SS, PEEK, Viton, FEP Teflon®
Flow Chamber Wetted Parts	Acrylic, 316 SS, Viton
Sensor Serviceability	Field replaceable membrane Field replaceable reference fill
Sensor Head Electronics	Integral Pre-amplifier
Display Mounting	Integral or remote (w/20' cable)
Available Communication Protocols	MODBUS RTU, DeviceNET, CANopen, EtherNet, USB, RJ-45, RS485

Regulatory	
Material Regulations	RoHS compliant assembly
DataStick	UL, CSA, and CE

7. Terms and Conditions

Terms and Conditions of Sale

The following terms and conditions will be presumed acceptable unless changes are made in writing and accepted by both parties in a reasonable amount of time.

Any standard or boilerplate terms and conditions supplied with a written purchase order will not be applicable unless accepted in writing by both parties.

Quotations: All quotations shall be in writing. Written quotations shall be valid for 30 days from the date issued. Verbal quotations or price lists are not valid.

Pricing: All pricing is in **US Dollars**. Thermo Fisher Scientific reserves the right to change pricing without notice.

Terms: Payment terms are **net 30 days** from the date of invoice with approved credit. Thermo Fisher Scientific reserves the right to deny credit or revoke previously extended credit. Past due accounts are subject to interest charges. Other acceptable payment terms are cash, certified check, money order, credit card or letter of credit confirmed by any United States of America bank. Other payment terms are not valid unless accepted in writing.

Sales taxes shall be included on the invoice unless a valid tax exemption certificate is supplied.

Return Material Authorization: Contact Thermo Fisher Scientific Customer Service for a Return Material Authorization (RMA) number. Items returned without an RMA number will be rejected.

All returned merchandise must be in unused, resalable condition, and must not be contaminated with hazardous materials.

Cancelled orders must be returned within 30 days of the date on the invoice and shall be subject to expenses incurred that may include, but are not limited to, inspection and restocking fees. Items returned within 60 days shall be subject to a restocking charge that is equal to 15% of the purchase price. Items returned after more than 60 days shall be subject to a restocking charge equal to 25% of the purchase price. Thermo Fisher Scientific reserves the right to reject any return that is not under warranty after 60 days. Non-stock items are normally not returnable.

Transportation: Orders are shipped FOB Thermo Fisher Scientific, or factory, by the most efficient means available. Appropriate charges, such as freight and insurance will be added to invoices. All shipments will be insured. Goods damaged in shipment must be reported by the recipient to the freight carrier for claims.

7.2 Terms and Conditions of Sale Continued

UNLESS OTHERWISE EXPRESSLY AGREED IN WRITING, ALL SALES ARE SUBJECT TO THE FOLLOWING TERMS AND CONDITIONS:

1. GENERAL. Thermo Orion Inc. ("Seller") hereby offers for sale to the buyer named on the face hereof ("Buyer") the products listed on the face hereof (the "Products") on the express condition that Buyer agrees to accept and be bound by the terms and conditions set forth herein. Any provisions contained in any document issued by Buyer are expressly rejected and if the terms and conditions in this Agreement differ from the terms of Buyer's offer, this document shall be construed as a counter offer and shall not be effective as an acceptance of Buyer's document. Buyer's receipt of Products or Seller's commencement of the services provided hereunder will constitute Buyer's acceptance of this Agreement. This is the complete and exclusive statement of the contract between Seller and Buyer with respect to Buyer's purchase of the Products. No waiver, consent, modification, amendment or change of the terms contained herein shall be binding unless in writing and signed by Seller and Buyer. Seller's failure to object to terms contained in any subsequent communication from Buyer will not be a waiver or modification of the terms set forth herein. All orders are subject to acceptance in writing by an authorized representative of Seller.

2. MINIMUM ORDER REQUIREMENTS. The minimum order requirement for dealers is \$225 for Buyer's products. The minimum order requirement for customers is \$40. An "order" is considered to be a purchase order for products to be shipped to a single location. International minimum order requirements may vary. Contact your International Customer Service Specialist for details.

3. PRICE. All prices published by Seller or quoted by Seller's representatives may be changed at any time without notice. All prices quoted by Seller or Seller's representatives are valid for thirty (30) days, unless otherwise stated in writing. All prices for the Products will be as specified by Seller or, if no price has been specified or quoted, will be Seller's price in effect at the time of shipment. All prices are subject to adjustment on account of specifications, quantities, shipment arrangements or other terms or conditions which are not part of Seller's original price quotation.

4. TAXES AND OTHER CHARGES. Prices for the Products exclude all federal, state, local property, license, privilege, sales, use, excise, gross receipt, sales, value added and other taxes and duties imposed with respect to the sale, delivery, or use of any Products covered hereby, all of which taxes and duties must be paid by Buyer. Such taxes are for the account of Buyer and Buyer agrees to pay or reimburse any such taxes which Seller, its affiliates, subsidiaries, contractors or suppliers are required to pay. If

Buyer claims any exemption, Buyer must provide a valid, signed certificate or letter of exemption for each respective jurisdiction.

5. TERMS OF PAYMENT. Seller may invoice Buyer upon shipment for the price and all other charges payable by Buyer in accordance with the terms on the face hereof. If no payment terms are stated on the face hereof, payment shall be net thirty (30) days from the date of invoice. If Buyer fails to pay any amounts when due, Buyer shall pay Seller interest thereon at a periodic rate of one and one-half percent (1.5%) per month (or, if lower, the highest rate permitted by law), together with all costs and expenses (including without limitation reasonable attorneys' fees and disbursements and court costs) incurred by Seller in collecting such overdue amounts or otherwise enforcing Seller's rights hereunder. Seller reserves the right to require from Buyer full or partial payment in advance, or other security that is satisfactory to Seller, at any time that Seller believes in good faith that Buyer's financial condition does not justify the terms of payment specified. All payments shall be made in U.S. Dollars.

6. DELIVERY; CANCELLATION OR CHANGES BY BUYER. Unless otherwise specified and accepted by Seller, the Products will be shipped to the destination specified by Buyer, F.O.B. Seller's facility in Beverly, Massachusetts. Freight and handling is prepaid and added to the invoice unless otherwise specified and agreed to in writing by the parties. Seller will have the right, at its election, to make partial shipments of the Products and to invoice each shipment separately. Seller reserves the right to stop delivery of Products in transit and to withhold shipments in whole or in part if Buyer fails to make any payment to Seller when due or otherwise fails to perform its obligations hereunder. All shipping dates are approximate only, and Seller will not be liable for any loss or damage resulting from any delay in delivery or failure to deliver which is due to any cause beyond Seller's reasonable control. In the event of a delay due to any cause beyond Seller's reasonable control, Seller reserves the right to terminate the order or to reschedule the shipment within a reasonable period of time, and Buyer will not be entitled to refuse delivery or otherwise be relieved of any obligations as the result of such delay. Products as to which delivery is delayed due to any cause within Buyer's control may be placed in storage by Seller at Buyer's risk and expense and for Buyer's account. Orders in process may be canceled only with Seller's written consent and upon payment of Seller's cancellation charges. Orders in process may not be changed except with Seller's written consent and upon agreement by the parties as to an appropriate adjustment in the purchase price therefor. Credit will not be allowed for Products returned without the prior written consent of Seller. Seller will not participate in a settlement of claims for concealed damage. Upon receipt of the Products, Buyer

must unpack immediately and, if damage is discovered, must: 1. not move the Product from the location where it was initially examined and damaged was discovered; 2. retain shipping container and packing material; 3. notify the carrier's agent to make an inspection; and 4. send Seller a copy of the carrier's inspection report.

7. DROP SHIPMENTS IN U.S. and CANADA. Drop shipments for Dealers will be made at a 5% penalty to current dealer discount (5% loss of discount) for the items to be shipped. Standard drop shipment orders will be shipped within five (5) business days of the order date, subject to stock availability. For faster processing, see rush orders below. Drop shipment is only available to U.S. and Canadian destinations.

8. RUSH ORDERS. For Buyers in the U.S.: Rush orders received before 12 Noon Eastern STD Time will be shipped the same day. Rush orders received after 12 Noon Eastern STD Time will be shipped the next business day. For Buyers in Canada: Rush orders will be shipped within two (2) business days. For Buyers outside the U.S. and Canada: Contact your International dealer for rush order scheduling. All rush orders carry a fifty dollar (\$50) incremental charge per order.

9. RETURN OF GOODS/RESTOCKING CHARGE
Permission to return new, excess inventory must be obtained prior to return within thirty days of original shipment. Contact for a return authorization number: Thermo Fisher Scientific Inc. Toll Free: 800.225.1480
Environmental Instruments Phone: 978.232.6000
Water Analysis Instruments Fax: 978.232.6015
(U.S. and Canada) 166 Cummings Center
Fax: 978.232.6031 (Outside U.S. and Canada)
Beverly, MA 01915
If any item authorized to be returned for credit, a 25% restocking charge of the price paid for the product will be made. (International Customer's restocking fee of 25% will be off the International price). Only new (in-the-box) goods may be returned within thirty (30) days of shipment from Seller. Older items, service parts, and discontinued items cannot be returned for credit.

10. SHORT SHIPMENTS. Seller must be notified within thirty (30) days of receipt of invoice of any item or billing discrepancies. All substantiated claims of short shipments will be remedied by a credit memo and a new order placed for short shipment. Any shipment discrepancy claimed after thirty (30) days of invoice date will not be honored and credit will not be issued by Seller.

11. TITLE AND RISK OF LOSS. Notwithstanding the trade terms indicated above and subject to the provisions of Section 12 below and to Seller's right to stop delivery of Products in transit, title to and risk of loss of the Products will pass to Buyer upon delivery of possession of the Products by Seller to the carrier; provided, however, that title to any software incorporated within or forming a part of the Products shall at all times remain with Seller or the licensor(s) thereof, as the case may be.

12. SECURITY INTEREST. Seller reserves and Buyer grants to Seller a purchase money security interest in all Products until such time as Buyer fully pays for such Products. Buyer agrees to assist Seller in taking the necessary steps to perfect and protect such security interest.

13. WARRANTY. Seller warrants that during the warranty period, the Products will operate substantially in conformance with Seller's published specifications and be free from defects in material and workmanship, when subjected to normal, proper and intended usage by properly trained personnel and not subject to accident, alteration, misuse, abuse, or breakage, for a period which varies based upon the Product purchased (see www.thermo.com/water) for the "Warranty Period". Seller agrees during the Warranty Period, provided it is promptly notified in writing upon the discovery of any defect and further provided that all costs of returning the defective Products to Seller are pre-paid by Buyer, to repair or replace, at Seller's option, defective Products so as to cause the same to operate in substantial conformance with said specifications. Replacement parts may be new or refurbished, at the election of Seller. All replaced parts shall become the property of Seller. Shipment to Buyer of repaired or replacement Products shall be made in accordance with the provisions of Section 6 above. Lamps, fuses, bulbs and other expendable items are expressly excluded from the warranty under this Section 13. There may be additional charges to Buyer, including freight, for warranty service performed in some countries. For service, call Thermo Fisher Scientific (or its authorized dealer outside the United States and Canada). Thermo Fisher Scientific reserves the right to ask for proof of purchase, such as the original invoice or packing slip. In no event shall Seller have any obligation to make repairs, replacements or corrections required, in whole or in part, as the result of (i) normal wear and tear, (ii) accident, disaster or event of force majeure, (iii) misuse, fault or negligence of or by Buyer, (iv) use of the Products in a manner for which they were not designed, (v) causes external to the Products such as, but not limited to, power failure or electrical power surges, (vi) improper storage of the Products or (vii) use of the Products in combination with equipment or software not supplied by Seller. If Seller determines that Products for which Buyer has requested warranty services are not covered by the warranty hereunder, Buyer shall pay or reimburse Seller for all costs of investigating and responding to such request at Seller's then prevailing time and materials rates. If Seller provides repair services or replacement parts that are not covered by the warranty provided in this Section

13. Buyer shall pay Seller therefor at Seller's then prevailing time and materials rates. ANY INSTALLATION, MAINTENANCE, REPAIR, SERVICE, RELOCATION OR ALTERATION TO OR OF, OR OTHER TAMPERING WITH, THE PRODUCTS PERFORMED BY ANY PERSON OR ENTITY OTHER THAN SELLER WITHOUT SELLER'S PRIOR WRITTEN APPROVAL, OR ANY USE OF REPLACEMENT PARTS NOT SUPPLIED BY SELLER, SHALL IMMEDIATELY VOID AND CANCEL ALL WARRANTIES WITH RESPECT TO THE AFFECTED

PRODUCTS. THE OBLIGATIONS CREATED BY THIS SECTION TO REPAIR OR REPLACE A DEFECTIVE PRODUCT SHALL BE THE SOLE REMEDY OF BUYER IN THE EVENT OF A DEFECTIVE PRODUCT. EXCEPT AS EXPRESSLY PROVIDED IN THIS SECTION 8, SELLER DISCLAIMS ALL WARRANTIES, WHETHER EXPRESS OR IMPLIED, ORAL OR WRITTEN, WITH RESPECT TO THE PRODUCTS, INCLUDING WITHOUT LIMITATION ALL IMPLIED WARRANTIES OF MERCHANTABILITY OR FITNESS FOR ANY PARTICULAR PURPOSE. REPRESENTATIONS AND WARRANTIES MADE BY ANY PERSON, INCLUDING SELLER'S AUTHORIZED DEALERS, REPRESENTATIVES AND EMPLOYEES WHICH ALTER OR ARE IN ADDITION TO THE TERMS OF THIS WARRANTY SHALL NOT BE BINDING UPON SELLER UNLESS AGREED UPON IN WRITING AND SIGNED BY ONE OF SELLER'S OFFICERS. SELLER DOES NOT WARRANT THAT THE PRODUCTS ARE ERROR-FREE OR WILL ACCOMPLISH ANY PARTICULAR RESULT.

14. INDEMNIFICATION.

14.1 By Seller. Seller agrees to indemnify, defend and save Buyer, its officer, directors, and employees from and against any and all damages, liabilities, actions, causes of action, suits, claims, demands, losses, costs and expenses (including without limitation reasonable attorney's fees) ("Indemnified Items") for (i) injury to or death of persons or damage to property to the extent caused by the negligence or willful misconduct of Seller, its employees, agents or representatives or contractors in connection with the performance of services at Buyer's premises under this Agreement and (ii) claims that a Product infringes any valid United States patent, copyright or trade secret; provided, however, Seller shall have no liability under this Section to the extent any such Indemnified Items are caused by either (i) the negligence or willful misconduct of Buyer, its employees, agents or representatives or contractors, (ii) by any third party, (iii) use of a Product in combination with equipment or software not supplied by Seller where the Product would not itself be infringing, (iv) compliance with Buyer's designs, specifications or instructions, (v) use of the Product in an application or environment for which it was not designed or (vi) modifications of the Product by anyone other than Seller without Seller's prior written approval. Buyer shall provide Seller prompt written notice of any third party claim covered by Seller's indemnification obligations hereunder. Seller shall have the right to assume exclusive control of the defense of such claim or, at the option of the Seller, to settle the same. Buyer agrees to cooperate reasonably with Seller in connection with the performance by Seller of its obligations in this Section. Notwithstanding the above, Seller's infringement related indemnification obligations shall be extinguished and relieved if Seller, at its discretion and at its own expense (a) procures for Buyer the right, at no additional expense to Buyer, to continue using the Product; (b) replaces or modifies the Product so that it becomes non-infringing, provided the modification or replacement does not adversely affect the specifications of the Product; or (c) in the event (a) and (b) are not practical, refund to Buyer the amortized amounts paid by Buyer with respect thereto, based on a five

(5) year amortization schedule. THE FOREGOING INDEMNIFICATION PROVISION STATES SELLER'S ENTIRE LIABILITY TO BUYER FOR THE CLAIMS DESCRIBED HEREIN.

14.2 By Buyer. Buyer shall indemnify, defend with competent and experienced counsel and hold harmless Seller, its parent, subsidiaries, affiliates and divisions, and their respective officers, directors, shareholders and employees, from and against any and all damages, liabilities, actions, causes of action, suits, claims, demands, losses, costs and expenses (including without limitation reasonable attorneys' fees and disbursements and court costs) to the extent arising from or in connection with (i) the negligence or willful misconduct of Buyer, its agents, employees, representatives or contractors; (ii) use of a Product in combination with equipment or software not supplied by Seller where the Product itself would not be infringing; (iii) Seller's compliance with designs, specifications or instructions supplied to Seller by Buyer; (iv) use of a Product in an application or environment for which it was not designed; or (v) modifications of a Product by anyone other than Seller without Seller's prior written approval.

15. SOFTWARE. With respect to any software products incorporated in or forming a part of the Products hereunder, Seller and Buyer intend and agree that such software products are being licensed and not sold, and that the words "purchase", "sell" or similar or derivative words are understood and agreed to mean "license", and that the word "Buyer" or similar or derivative words are understood and agreed to mean "licensee". Notwithstanding anything to the contrary contained herein, Seller or its licensor, as the case may be, retains all rights and interest in software products provided hereunder. Seller hereby grants to Buyer a royalty-free, non-exclusive, nontransferable license, without power to sublicense, to use software provided hereunder solely for Buyer's own internal business purposes on the hardware products provided hereunder and to use the related documentation solely for Buyer's own internal business purposes. This license terminates when Buyer's lawful possession of the hardware products provided hereunder ceases, unless earlier terminated as provided herein. Buyer agrees to hold in confidence and not to sell, transfer, license, loan or otherwise make available in any form to third parties the software products and related documentation provided hereunder. Buyer may not disassemble, decompile or reverse engineer, copy, modify, enhance or otherwise change or supplement the software products provided hereunder without Seller's prior written consent. Seller will be entitled to terminate this license if Buyer fails to comply with any term or condition herein. Buyer agrees, upon termination of this license, immediately to return to Seller all software products and related documentation provided hereunder and all copies and portions thereof. Certain of the software products provided by Seller may be owned by one or more third parties and licensed to Seller. Accordingly, Seller and Buyer agree that such third parties retain ownership of and title to such software products. The warranty and indemnification

provisions set forth herein shall not apply to software products owned by third parties and provided hereunder.

16. LIMITATION OF LIABILITY. NOTWITHSTANDING ANYTHING TO THE CONTRARY CONTAINED HEREIN, THE LIABILITY OF SELLER UNDER THESE TERMS AND CONDITIONS (WHETHER BY REASON OF BREACH OF CONTRACT, TORT, INDEMNIFICATION, OR OTHERWISE, BUT EXCLUDING LIABILITY OF SELLER FOR BREACH OF WARRANTY (THE SOLE REMEDY FOR WHICH SHALL BE AS PROVIDED UNDER SECTION 13 ABOVE)) SHALL NOT EXCEED AN AMOUNT EQUAL TO THE LESSER OF (A) THE TOTAL PURCHASE PRICE THERETOFORE PAID BY BUYER TO SELLER WITH RESPECT TO THE PRODUCT(S) GIVING RISE TO SUCH LIABILITY OR (B) ONE HUNDRED THOUSAND DOLLARS (\$100,000). NOTWITHSTANDING ANYTHING TO THE CONTRARY CONTAINED HEREIN, IN NO EVENT SHALL SELLER BE LIABLE FOR ANY INDIRECT, SPECIAL, CONSEQUENTIAL OR INCIDENTAL DAMAGES (INCLUDING WITHOUT LIMITATION DAMAGES FOR LOSS OF USE OF FACILITIES OR EQUIPMENT, LOSS OF REVENUE, LOSS OF DATA, LOSS OF PROFITS OR LOSS OF GOODWILL), REGARDLESS OF WHETHER SELLER (a) HAS BEEN INFORMED OF THE POSSIBILITY OF SUCH DAMAGES OR (b) IS NEGLIGENT.

17. EXPORT RESTRICTIONS. Buyer acknowledges that each Product and any related software and technology, including technical information supplied by Seller or contained in documents (collectively "Items"), is subject to export controls of the U.S. government. The export controls may include, but are not limited to, those of the Export Administration Regulations of the U.S. Department of Commerce (the "EAR"), which may restrict or require licenses for the export of Items from the United States and their re-export from other countries. Buyer shall comply with the EAR and all other applicable laws, regulations, laws, treaties, and agreements relating to the export, re-export, and import of any Item. Buyer shall not, without first obtaining the required license to do so from the appropriate U.S. government agency: (i) export or re-export any Item, or (ii) export, re-export, distribute or supply any Item to any restricted or embargoed country or to a person or entity whose privilege to participate in exports has been denied or restricted by the U.S. government. Buyer shall cooperate fully with Seller in any official or unofficial audit or inspection related to applicable export or import control laws or regulations, and shall indemnify and hold Seller harmless from, or in connection with, any violation of this Section by Buyer or its employees, consultants, agents, or customers.

18. HAZARDOUS MATERIALS. Some Products may require special labeling and handling. Carriers may add additional freight charges for handling/transporting these materials. Consolidating such material with other products may be prohibited. Additional freight charges will be billed per Seller's shipping terms. Be sure to advise Seller of shipping instructions for these hazardous materials to reduce your freight costs.

19. MISCELLANEOUS. (a) Buyer may not delegate any duties nor assign any rights or claims hereunder without Seller's prior written consent, and any such attempted delegation or assignment shall be void. (b) The rights and obligations of the parties hereunder shall be governed by and construed in accordance with the laws of the Commonwealth of Massachusetts, without reference to its choice of law provisions. Each party hereby irrevocably consents to the exclusive jurisdiction of the state and federal courts located in Suffolk County, Massachusetts, in any action arising out of or relating to this Agreement and waives any other venue to which it may be entitled by domicile or otherwise. (c) In the event of any legal proceeding between the Seller and Buyer relating to this Agreement, neither party may claim the right to a trial by jury, and both parties waive any right they may have under applicable law or otherwise to a right to a trial by jury. Any action arising under this Agreement must be brought within one (1) year from the date that the cause of action arose. (d) The application to this Agreement of the U.N. Convention on Contracts for the International Sale of Goods is hereby expressly excluded. (e) In the event that any one or more provisions contained herein shall be held by a court of competent jurisdiction to be invalid, illegal or unenforceable in any respect, the validity, legality and enforceability of the remaining provisions contained herein shall remain in full force and effect, unless the revision materially changes the bargain. (f) Seller's failure to enforce, or Seller's waiver of a breach of, any provision contained herein shall not constitute a waiver of any other breach or of such provision. (g) Any notice or communication required or permitted hereunder shall be in writing and shall be deemed received when personally delivered or three (3) business days after being sent by certified mail, postage prepaid, to a party at the address specified herein or at such other address as either party may from time to time designate to the other.

Process Water Instruments

North America

166 Cummings Center
Beverly, MA 01915 USA
Toll Free: 1-800-225-1480
Tel: 1-978-232-6000
info.water@thermo.com

Netherlands

Tel: (31) 033-2463887
info.water.uk@thermo.com

India

Tel: (91) 22-4157-8800
wai.asia@thermofisher.com

Japan

Tel: (81) 045-453-9175
wai.asia@thermofisher.com

China

Tel: (86) 21-68654588
wai.asia@thermofisher.com

Singapore

Tel: (65) 6778-6876
wai.asia@thermofisher.com

Australia

Tel: (613) 9757-4300
infowaterau@thermofisher.com



© 2012 Thermo Fisher Scientific Inc. All rights reserved.