

Human TGF beta1 ELISA Kit

Enzyme-linked Immunosorbent Assay for quantitative detection of human TGF β 1

Catalog Numbers BMS249-4 and BMS249-4TEN

Pub. No. MAN0016624 **Rev.** A.0 (30)

WARNING! Read the Safety Data Sheets (SDSs) and follow the handling instructions. Wear appropriate protective eyewear, clothing, and gloves. Safety Data Sheets (SDSs) are available from thermofisher.com/support.

Product description

The Human TGF beta1 ELISA Kit is an enzyme-linked immunosorbent assay for the quantitative detection of human TGF β 1.

Summary

Transforming growth factor β (TGF β) is a pleiotropic cytokine that exhibits a broad spectrum of biological and regulatory effects on the cellular and organism level. It plays a critical role in cellular growth, development, differentiation, proliferation, extracellular matrix (ECM) synthesis and degradation, control of mesenchymal-epithelial interactions during embryogenesis, immune modulation, apoptosis, cell cycle progression, angiogenesis, adhesion and migration and leukocyte chemotaxis. It has both tumor suppressive and tumor promoting activities and is highly regulated at all levels (e.g.: mRNA turnover, latent protein activation or post-translational modifications).

TGF β is the first recognized protein of at least 40 of the TGF β superfamily of structurally related cytokines.

Three isoforms (TGF β 1-3) have been described in mammals. (Each isoform is encoded by a unique gene on different chromosomes. All bind to the same receptors.) They are synthesized by most cell types and tissues. Cells of the immune system mainly express TGF β 1.

The initially sequestered, inactive LTGF β (latent TGF β) requires activation (cleavage and dissociation of its LAP (latency associated peptide) region) before it can exert biological activity. LTGF β can also be bound to LTBP (latent TGF β binding protein) to form a large latent complex (LLC). TGF β forms homodimers, and its subunits of 12.5 kDa each are bound via disulphide bridges.

TGF β signal transduction is mediated via the TGF β receptors Type II and I, phosphorylation and conformational changes, followed by different pathways:

SMAD (- pathway: TGF β recruitment finally leads to phosphorylation of receptor-regulated SMADs (R-SMADs = SMAD 2, 3) and binding of common SMAD (coSMAD = SMAD 4). The R-SMAD/ coSMAD complex enters the nucleus and interacts with a number of transcription factors, coactivators and corepressors.

TGF β induces MAPK- and MAP/ERK kinase dependent signal transduction (JNK/MAPK-, JNK/SPAK-, p38-, ERK1/2 - pathway) and the NF- κ B – pathway. TGF β mediates cell cycle growth arrest via the phosphoinositide 3-kinase/Akt pathway.

TGF β signaling is highly regulated e.g. via interaction with inhibitory SMADs (I-SMADs = SMAD 6, 7) or binding of the E3-ubiquitin ligases Smurf1 and Smurf2 or/and coreceptors.

TGF β 1 is the key mediator in the pathophysiology of tissue repair and human fibrogenesis: balance between production and degradation of type I collagen, and fibrosis and scarring in organ and tissue.

TGF β 1 exhibits important immunoregulatory features of partially adverse character: TGF β 1 inhibits B and T cell proliferation, differentiation and antibody production as well as maturation and

activation of macrophages. It inhibits activity of NK cells and lymphokine activated killer cells and blocks production of cytokines. TGF β 1 promotes Treg cell differentiation resulting in IL-10/TGF β 1 production and Th1 cell and Th2 cell suppression.

TGF β 1 was recently shown to promote Th17 development in the presence of IL-6 or IL-21 in mice and probably plays a role in human Th17 development together with IL-1 β , IL-21 and IL-23. In this context TGF β 1 is involved in induction and mediation of proinflammatory and allergic responses.

For literature update refer to our website.

Principles of the test

An anti-human TGF β 1 coating antibody is adsorbed onto microwells.

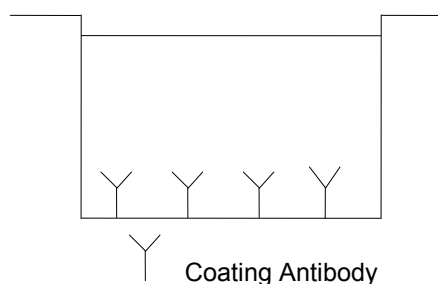

Fig. 1 Coated microwell

Human TGF β 1 present in the sample or standard binds to antibodies adsorbed to the microwells.

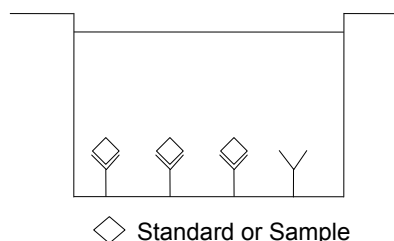

Fig. 2 First incubation

A biotin-conjugated anti-human TGF β 1 antibody is added and binds to human TGF β 1 captured by the first antibody.

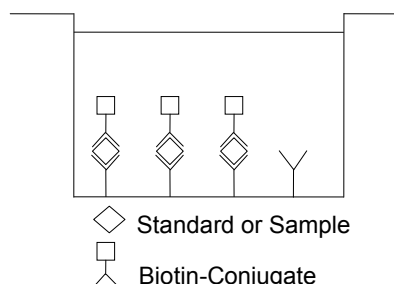

Fig. 3 Second incubation

Following incubation unbound biotin-conjugated anti-human TGF β 1 antibody is removed during a wash step. Streptavidin-HRP is added and binds to the biotin-conjugated anti-human TGF β 1 antibody.

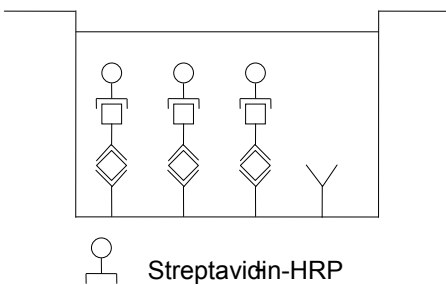

Fig. 4 Third incubation

Following incubation unbound Streptavidin-HRP is removed during a wash step, and substrate solution reactive with HRP is added to the wells.

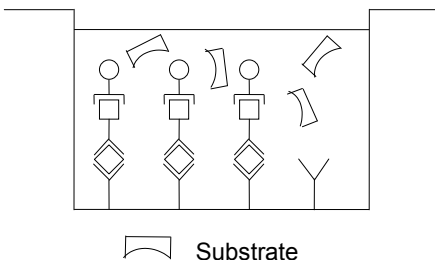

Fig. 5 Fourth incubation

A colored product is formed in proportion to the amount of human TGF β 1 present in the sample or standard. The reaction is terminated by addition of acid and absorbance is measured at 450 nm. A standard curve is prepared from 7 human TGF β 1 standard dilutions and human TGF β 1 sample concentration determined.

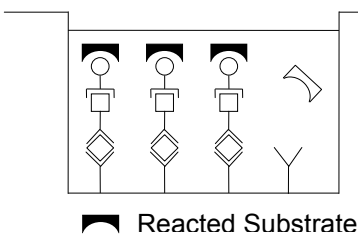

Fig. 6 Stop reaction

Reagents provided

Reagents for human TGF β 1 ELISA BMS249/4 (96 tests)

1 aluminum pouch with a Microwell Plate (12 strips with 8 wells each) coated with monoclonal antibody to human TGF β 1

1 vial (120 μ L) Biotin-Conjugate anti-human TGF β 1 monoclonal antibody

1 vial (150 μ L) Streptavidin-HRP

2 vials human TGF β 1 Standard lyophilized, 4 ng/mL upon reconstitution

1 vial (5 mL) Assay Buffer Concentrate 20x (PBS with 1% Tween[™] 20, 10% BSA)

1 bottle (50 mL) Wash Buffer Concentrate 20x (PBS with 1% Tween[™] 20)

1 vial (15 mL) Substrate Solution (tetramethyl-benzidine)

1 vial (15 mL) Stop Solution (1M Phosphoric acid)

6 Adhesive Films

Reagents for human TGF β 1 ELISA BMS249/4TEN (10x96 tests)

10 aluminum pouches with a Microwell Plate (12 strips with 8 wells each) coated with monoclonal antibody to human TGF β 1

10 vials (120 μ L) Biotin-Conjugate anti-human TGF β 1 monoclonal antibody

10 vials (150 μ L) Streptavidin-HRP

10 vials human TGF β 1 Standard lyophilized, 4 ng/mL upon reconstitution

5 vials (5 mL) Assay Buffer Concentrate 20x (PBS with 1% Tween[™] 20, 10% BSA)

7 bottles (50 mL) Wash Buffer Concentrate 20x (PBS with 1% Tween[™] 20)

10 vials (15 mL) Substrate Solution (tetramethyl-benzidine)

1 vial (100 mL) Stop Solution (1M Phosphoric acid)

30 Adhesive Films

Storage instructions – ELISA kit

Store kit reagents between 2° and 8°C. Immediately after use remaining reagents should be returned to cold storage (2° to 8°C).

Expiry of the kit and reagents is stated on labels. Expiry of the kit components can only be guaranteed if the components are stored properly, and if, in case of repeated use of one component, this reagent is not contaminated by the first handling.

Sample collection and storage instructions

Cell culture supernatant, serum, and plasma (EDTA, citrate, heparin) were tested with this assay. Other biological samples might be suitable for use in the assay. Remove serum or plasma from the clot or cells as soon as possible after clotting and separation.

Note: Pay attention to a possibly elevated blank signal in cell culture supernatant samples containing serum components (e.g. FCS), due to latent TGF β levels in animal serum.

Samples containing a visible precipitate must be clarified prior to use in the assay. Do not use grossly hemolyzed or lipemic samples.

Samples should be aliquoted and must be stored frozen at -20°C to avoid loss of bioactive human TGF β 1. If samples are to be run within 24 hours, they may be stored at 2-8°C (for sample stability refer to "Sample stability" on page 6).

Avoid repeated freeze-thaw cycles. Prior to assay, the frozen sample should be brought to room temperature slowly and mixed gently.

Materials required but not provided

- 1N NaOH and 1N HCL are needed to run the test
- 5 mL and 10 mL graduated pipettes
- 5 μ L to 1000 μ L adjustable single channel micropipettes with disposable tips
- 50 μ L to 300 μ L adjustable multichannel micropipette with disposable tips
- Multichannel micropipette reservoir
- Beakers, flasks, cylinders necessary for preparation of reagents
- Device for delivery of wash solution (multichannel wash bottle or automatic wash system)
- Microplate shaker
- Microwell strip reader capable of reading at 450 nm (620 nm as optional reference wave length)
- Glass-distilled or deionized water
- Statistical calculator with program to perform regression analysis

Precautions for use

- All chemicals should be considered as potentially hazardous. We therefore recommend that this product is handled only by those persons who have been trained in laboratory techniques and that it is used in accordance with the principles of good laboratory practice. Wear suitable protective clothing such as laboratory overalls, safety glasses, and gloves. Care should be taken to avoid contact with skin or eyes. In the case of contact with skin or eyes wash immediately with water. See material safety data sheet(s) and/or safety statement(s) for specific advice.
- Reagents are intended for research use only and are not for use in diagnostic or therapeutic procedures.
- Do not mix or substitute reagents with those from other lots or other sources.
- Do not use kit reagents beyond expiration date on label.

- Do not expose kit reagents to strong light during storage or incubation.
- Do not pipet by mouth.
- Do not eat or smoke in areas where kit reagents or samples are handled.
- Avoid contact of skin or mucous membranes with kit reagents or samples.
- Rubber or disposable latex gloves should be worn while handling kit reagents or samples.
- Avoid contact of substrate solution with oxidizing agents and metal.
- Avoid splashing or generation of aerosols.
- To avoid microbial contamination or cross-contamination of reagents or samples that may invalidate the test, use disposable pipette tips and/or pipettes.
- Use clean, dedicated reagent trays for dispensing the conjugate and substrate reagent.
- Exposure to acid inactivates the conjugate.
- Glass-distilled water or deionized water must be used for reagent preparation.
- Substrate solution must be at room temperature prior to use.
- Decontaminate and dispose samples and all potentially contaminated materials as if they could contain infectious agents. The preferred method of decontamination is autoclaving for a minimum of 1 hour at 121.5°C.
- Liquid wastes not containing acid and neutralized waste may be mixed with sodium hypochlorite in volumes such that the final mixture contains 1.0% sodium hypochlorite. Allow 30 minutes for effective decontamination. Liquid waste containing acid must be neutralized prior to the addition of sodium hypochlorite.

Preparation of reagents

1. Buffer Concentrates should be brought to room temperature and should be diluted before starting the test procedure.
2. If crystals have formed in the Buffer Concentrates, warm them gently until they have completely dissolved.

Wash buffer (1x)

1. Pour entire contents (50 mL) of the Wash Buffer Concentrate (20x) into a clean 1000 mL graduated cylinder. Bring to final volume of 1000 mL with glass-distilled or deionized water.
2. Mix gently to avoid foaming.
3. Transfer to a clean wash bottle and store at 2° to 25°C. Please note that Wash Buffer (1x) is stable for 30 days.
4. Wash Buffer (1x) may also be prepared as needed according to the following table:

Number of Strips	Wash Buffer Concentrate (20x) (mL)	Distilled Water (mL)
1 - 6	25	475
1 - 12	50	950

Assay buffer (1x)

1. Pour the entire contents (5 mL) of the Assay Buffer Concentrate (20x) into a clean 100 mL graduated cylinder. Bring to final volume of 100 mL with distilled water. Mix gently to avoid foaming.
2. Store at 2° to 8°C. Please note that the Assay Buffer (1x) is stable for 30 days.
3. Assay Buffer (1x) may also be prepared as needed according to the following table:

Number of Strips	Assay Buffer Concentrate (20x) (mL)	Distilled Water (mL)
1 - 6	2.5	47.5
1 - 12	5.0	95.0

Biotin-Conjugate

Note: The Biotin-Conjugate should be used within 30 minutes after dilution.

Make a 1:100 dilution of the concentrated Biotin-Conjugate solution with Assay Buffer (1x) in a clean plastic tube as needed according to the following table:

Number of Strips	Biotin-Conjugate (mL)	Assay Buffer (1x) (mL)
1 - 6	0.06	5.94
1 - 12	0.12	11.88

Streptavidin-HRP

Note: The Streptavidin-HRP should be used within 30 minutes after dilution.

Make a 1:100 dilution of the concentrated Streptavidin-HRP solution with Assay Buffer (1x) in a clean plastic tube as needed according to the following table:

Number of Strips	Streptavidin-HRP (mL)	Assay Buffer (1x) (mL)
1 - 6	0.06	5.94
1 - 12	0.12	11.88

Human TGF β 1 standard

1. Reconstitute human TGF β 1 standard by addition of distilled water. Reconstitution volume is stated on the label of the standard vial. Swirl or mix gently to insure complete and homogeneous solubilization (concentration of reconstituted standard = 4 ng/mL).
2. Allow the standard to reconstitute for 10-30 minutes. Mix well prior to making dilutions.
3. After usage remaining standard cannot be stored and has to be discarded.
4. Standard dilutions can be prepared directly on the microwell plate (see "Test protocol" on page 4) or alternatively in tubes (see "External standard dilution" on page 3).

External standard dilution

1. Label 7 tubes, one for each standard point: S1, S2, S3, S4, S5, S6, S7.
2. Prepare 1:2 serial dilutions for the standard curve as follows: Pipette 225 µL of Assay Buffer (1x) into each tube.
3. Pipette 225 µL of reconstituted standard (concentration of standard = 4 ng/mL) into the first tube, labeled S1, and mix (concentration of standard 1 = 2 ng/mL).
4. Pipette 225 µL of this dilution into the second tube, labeled S2, and mix thoroughly before the next transfer.
5. Repeat serial dilutions 5 more times thus creating the points of the standard curve (see Figure 7).

Assay Buffer (1x) serves as blank.

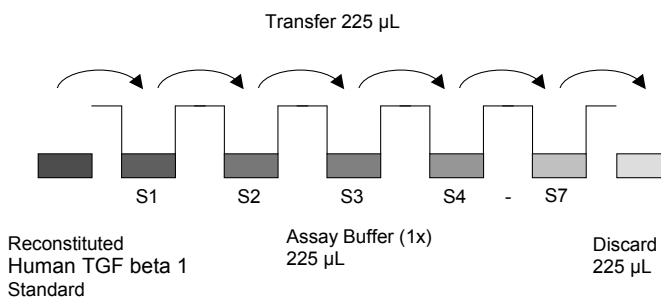

Fig. 7 Dilute standards - tubes

Test protocol

1. Prepare your samples before starting the test procedure. Dilute serum, plasma and cell culture supernatant samples 1:10 with Assay Buffer (1x) according to the following scheme:
20 µL sample + 180 µL Assay Buffer (1x)
Add 20 µL 1N HCl (see "Materials required but not provided" on page 2) to 200 µL prediluted sample, mix and incubate for 1 hour at room temperature.

Neutralize by addition of 20 µL 1N NaOH (see "Materials required but not provided" on page 2). Vortex!

2. Determine the number of microwell strips required to test the desired number of samples plus appropriate number of wells needed for running blanks and standards. Each sample, standard, blank and optional control sample should be assayed in duplicate. Remove extra microwell strips from holder and store in foil bag with the desiccant provided at 2°-8°C sealed tightly.
3. Wash the microwell strips twice with approximately 400 µL Wash Buffer per well with thorough aspiration of microwell contents between washes. Allow the Wash Buffer to sit in the wells for about 10 – 15 seconds before aspiration. Take care not to scratch the surface of the microwells.

After the last wash step, empty wells and tap microwell strips on absorbent pad or paper towel to remove excess Wash Buffer. Use the microwell strips immediately after washing. Alternatively microwell strips can be placed upside down on a wet absorbent paper for not longer than 15 minutes. Do not allow wells to dry.

4. Standard dilution on the microwell plate (Alternatively the standard dilution can be prepared in tubes – see "External standard dilution" on page 3):

Add 100 µL of Assay Buffer (1x) in duplicate to all standard wells. Pipette 100 µL of prepared standard (see Preparation of Standard "Human TGF β 1 standard" on page 3, concentration = 4000 pg/mL) in duplicate into well A1 and A2 (see Table 1). Mix the contents of wells A1 and A2 by repeated aspiration and ejection (concentration of standard 1, S1 =2000 pg/mL), and transfer 100 µL to wells B1 and B2, respectively (see Figure 8). Take care not to scratch the inner surface of the microwells. Continue this procedure 5 times, creating two rows of human TGF β 1 standard dilutions ranging from 2000 to 31 pg/mL. Discard 100 µL of the contents from the last microwells (G1, G2) used.

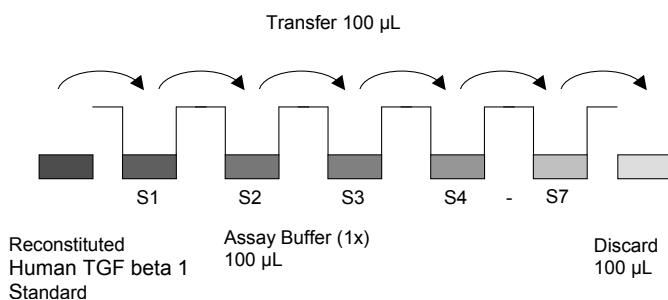

Fig. 8 Dilute standards - microwell plate

Table 1 Example of the arrangement of blanks, standards and samples in the microwell strips.

	1	2	3	4
A	Standard 1 2000 pg/mL	Standard 1 2000 pg/mL	Sample 1	Sample 1
B	Standard 2 1000 pg/mL	Standard 2 1000 pg/mL	Sample 2	Sample 2
C	Standard 3 500 pg/mL	Standard 3 500 pg/mL	Sample 3	Sample 3
D	Standard 4 250 pg/mL	Standard 4 250 pg/mL	Sample 4	Sample 4
E	Standard 5 125 pg/mL	Standard 5 125 pg/mL	Sample 5	Sample 5
F	Standard 6 63 pg/mL	Standard 6 63 pg/mL	Sample 6	Sample 6
G	Standard 7 31 pg/mL	Standard 7 31 pg/mL	Sample 7	Sample 7
H	Blank	Blank	Sample 8	Sample 8

In case of an external standard dilution (see "External standard dilution" on page 3), pipette 100 µL of these standard dilutions (S1 - S7) in the standard wells according to Table 1.

5. Add 100 µL of Assay Buffer (1x) in duplicate to the blank wells.
6. Add 60 µL of Assay Buffer (1x) to the sample wells.
7. Add 40 µL of each pretreated sample in duplicate to the sample wells. (It is absolutely necessary to vortex the samples!)
8. Cover with an adhesive film and incubate at room temperature (18 to 25°C) for 2 hours, on a microplate shaker. (Shaking is absolutely necessary for an optimal test performance.)
9. Prepare Biotin-Conjugate (see Preparation of Biotin-Conjugate "Biotin-Conjugate" on page 3).
10. Remove adhesive film and empty wells. Wash microwell strips 5 times according to point 3. of the test protocol. Proceed immediately to the next step.
11. Add 100 µL of Biotin-Conjugate to all wells.
12. Cover with an adhesive film and incubate at room temperature (18 to 25°C) for 1 hour, on a microplate shaker. (Shaking is absolutely necessary for an optimal test performance.)
13. Prepare Streptavidin-HRP (refer to Preparation of Streptavidin-HRP "Streptavidin-HRP" on page 3).
14. Remove adhesive film and empty wells. Wash microwell strips 5 times according to point 3. of the test protocol. Proceed immediately to the next step.
15. Add 100 µL of diluted Streptavidin-HRP to all wells, including the blank wells.
16. Cover with an adhesive film and incubate at room temperature (18° to 25°C) for 1 hour, on a microplate shaker. (Shaking is absolutely necessary for an optimal test performance.)
17. Remove adhesive film and empty wells. Wash microwell strips 5 times according to point 3. of the test protocol. Proceed immediately to the next step.
18. Pipette 100 µL of TMB Substrate Solution to all wells.
19. Incubate the microwell strips at room temperature (18° to 25°C) for about 30 minutes. Avoid direct exposure to intense light.

The color development on the plate should be monitored and the substrate reaction stopped (see next point of this protocol) before positive wells are no longer properly recordable. Determination of the ideal time period for color development has to be done individually for each assay.

It is recommended to add the stop solution when the highest standard has developed a dark blue color. Alternatively the color development can be monitored by the ELISA reader at 620 nm. The substrate reaction should be stopped as soon as Standard 1 has reached an OD of 0.9 – 0.95.

20. Stop the enzyme reaction by quickly pipetting 100 μ L of Stop Solution into each well. It is important that the Stop Solution is spread quickly and uniformly throughout the microwells to completely inactivate the enzyme. Results must be read immediately after the Stop Solution is added or within one hour if the microwell strips are stored at 2 - 8°C in the dark.
21. Read absorbance of each microwell on a spectro-photometer using 450 nm as the primary wave length (optionally 620 nm as the reference wave length; 610 nm to 650 nm is acceptable). Blank the plate reader according to the manufacturer's instructions by using the blank wells. Determine the absorbance of both the samples and the standards.

Note: In case of incubation without shaking the obtained O.D. values may be lower than indicated below. Nevertheless the results are still valid.

Calculation of results

- Calculate the average absorbance values for each set of duplicate standards and samples. Duplicates should be within 20 percent of the mean value.
- Create a standard curve by plotting the mean absorbance for each standard concentration on the ordinate against the human TGF β 1 concentration on the abscissa. Draw a best fit curve through the points of the graph (a 5-parameter curve fit is recommended).
- To determine the concentration of circulating human TGF β 1 for each sample, first find the mean absorbance value on the ordinate and extend a horizontal line to the standard curve. At the point of intersection, extend a vertical line to the abscissa and read the corresponding human TGF β 1 concentration.
- If instructions in this protocol have been followed, samples have been diluted 1:30 (20 μ L sample + 180 μ L Assay Buffer (1x) + 20 μ L 1N HCl + 20 μ L 1N NaOH and 40 μ L pretreated sample + 60 μ L Assay Buffer (1x)) and the concentration read from the standard curve must be multiplied by the dilution factor (\times 30).
- Calculation of samples with a concentration exceeding standard 1 may result in incorrect, low human TGF β 1 levels. Such samples require further external predilution according to expected human TGF β 1 values with Assay Buffer (1x) in order to precisely quantitate the actual human TGF β 1 level.
- It is suggested that each testing facility establishes a control sample of known human TGF β 1 concentration and runs this additional control with each assay. If the values obtained are not within the expected range of the control, the assay results may be invalid.

- A representative standard curve is shown in Figure 9.

Note: Do not use this standard curve to derive test results. Each laboratory must prepare a standard curve for each group of microwell strips assayed.

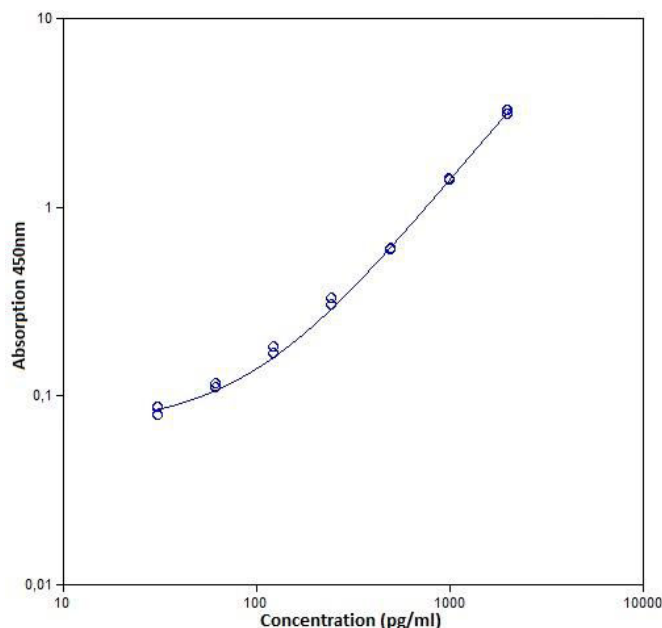

Fig. 9 Representative standard curve for human TGF β 1 ELISA. Human TGF β 1 was diluted in serial 2-fold steps in Assay Buffer (1x).

Table 2 Typical data using the human TGF β 1 ELISA.

Measuring wavelength: 450 nm

Reference wavelength: 620 nm

Standard	Human TGF β 1 Concentration (pg/mL)	O.D. at 450 nm	Mean O.D. at 450 nm	C.V. (%)
1	2000	3.227 3.068	3.148	2.5%
2	1000	1.373 1.402	1.387	1.0%
3	500	0.587 0.592	0.590	0.4%
4	250	0.300 0.326	0.313	4.1%
5	125	0.178 0.166	0.172	3.5%
6	63	0.109 0.114	0.112	2.0%
7	31	0.078 0.086	0.082	4.7%
Blank	0	0.052 0.050	0.051	2.0%

The OD values of the standard curve may vary according to the conditions of assay performance (e.g., operator, pipetting technique, washing technique, or temperature effects). Furthermore, shelf life of the kit may affect enzymatic activity and thus color intensity. Values measured are still valid.

Limitations

- Since exact conditions may vary from assay to assay, a standard curve must be established for every run.
- Bacterial or fungal contamination of either screen samples or reagents or cross-contamination between reagents may cause erroneous results.

- Disposable pipette tips, flasks or glassware are preferred, reusable glassware must be washed and thoroughly rinsed of all detergents before use.
- Improper or insufficient washing at any stage of the procedure will result in either false positive or false negative results. Empty wells completely before dispensing fresh wash solution, fill with Wash Buffer as indicated for each wash cycle and do not allow wells to sit uncovered or dry for extended periods.
- The use of radioimmunotherapy has significantly increased the number of patients with human anti-mouse IgG antibodies (HAMA). HAMA may interfere with assays utilizing murine monoclonal antibodies leading to both false positive and false negative results. Serum samples containing antibodies to murine immunoglobulins can still be analyzed in such assays when murine immunoglobulins (serum, ascitic fluid, or monoclonal antibodies of irrelevant specificity) are added to the sample.

Performance characteristics

Sensitivity

The limit of detection of human TGF β 1 defined as the analyte concentration resulting in an absorbance significantly higher than that of the dilution medium (mean plus 2 standard deviations) was determined to be 8.6 pg/mL (mean of 6 independent assays).

Reproducibility

Intra-assay

Reproducibility within the assay was evaluated in 3 independent experiments. Each assay was carried out with 6 replicates of 8 serum samples containing different concentrations of human TGF β 1. 2 standard curves were run on each plate. Data below show the mean human TGF β 1 concentration and the coefficient of variation for each sample (see Table 3). The calculated overall intra-assay coefficient of variation was 3.2%.

Table 3 The mean human TGF β 1 concentration and the coefficient of variation for each sample

Sample	Experiment	Mean Human TGF β 1 Concentration (pg/mL)	Coefficient of Variation (%)
1	1	38237.8	3.6%
	2	39660.8	2.6%
	3	39216.3	0.8%
2	1	20394.0	1.4%
	2	21289.3	3.0%
	3	21513.2	2.5%
3	1	22408.0	2.1%
	2	23957.9	3.4%
	3	24232.4	1.8%
4	1	18901.8	1.7%
	2	19649.6	3.0%
	3	21305.9	8.3%
5	1	4428.0	2.9%
	2	4723.3	2.8%
	3	4670.0	7.1%
6	1	4764.2	3.2%
	2	5063.1	2.5%
	3	4703.2	4.6%
7	1	3357.8	2.2%
	2	3887.2	3.2%
	3	3212.4	5.5%
8	1	4159.7	2.5%
	2	4455.3	2.1%
	3	3924.2	4.5%

Inter-assay

Assay to assay reproducibility within one laboratory was evaluated in 3 independent experiments. Each assay was carried out with 6

replicates of 8 serum plasma samples containing different concentrations of human TGF β 1. 2 standard curves were run on each plate. Data below show the mean human TGF β 1 concentration and the coefficient of variation calculated on 18 determinations of each sample (see Table 4). The calculated overall inter-assay coefficient of variation was 4.9%.

Table 4 The mean human TGF β 1 concentration and the coefficient of variation of each sample

Sample	Mean Human TGF β 1 Concentration (pg/mL)	Coefficient of Variation (%)
1	39038.3	1.9 %
2	21065.5	2.8 %
3	23532.8	4.2 %
4	19952.4	6.2 %
5	4607.1	3.4 %
6	4843.5	4.0 %
7	3485.8	10.2 %
8	4179.7	6.4 %

Spike recovery

The spike recovery was evaluated by spiking 3 levels of human TGF β 1 into serum, plasma, and cell culture supernatant. Recoveries were determined with 4 replicates each. The amount of endogenous human TGF β 1 in unspiked samples was subtracted from the spike values.

Sample matrix	Spike high (%)		Spike medium (%)		Spike low (%)	
	Mean	Range	Mean	Range	Mean	Range
Serum	85	83–87	97	96–99	96	92–101
Plasma (EDTA)	90	80–114	84	74–97	82	78–85
Plasma (citrate)	108	96–122	92	88–95	92	88–96
Plasma (heparin)	110	98–119	87	87–110	93	87–100
Cell culture supernatant	87	85–89	85	84–85	95	92–98

Dilution parallelism

Serum, plasma, and cell culture supernatant samples with different levels of human TGF β 1 were analyzed at serial 2-fold dilutions with 4 replicates each (except for CCS with only 1 replicate).

Sample matrix	Dilution	Recovery of exp. val. (%)	
		Mean	Range
Serum	1:60	103	93–108
	1:120	112	81–128
	1:240	97	75–113
Plasma (EDTA)	1:60	119	114–128
	1:120	129	118–142
	1:240	138	127–150
Plasma (citrate)	1:60	108	102–113
	1:120	119	110–128
	1:240	130	112–139
Plasma (heparin)	1:60	121	112–134
	1:120	130	119–150
	1:240	126	120–131
Cell culture supernatant	1:60	95	–
	1:120	103	–
	1:240	118	–

Sample stability

Freeze-Thaw stability

Aliquots of serum samples (spiked or unspiked) were stored at -20°C and thawed 5 times, and the human TGF β 1 levels determined. There was no significant loss of human TGF β 1 immunoreactivity detected by freezing and thawing.

Storage stability

Aliquots of serum samples (spiked or unspiked) were stored at -20°C , $2-8^{\circ}\text{C}$, and room temperature, and the human TGF β 1 level determined after 24 hours. There was no significant loss of human TGF β 1 immunoreactivity detected during storage under above conditions.

Specificity

The assay detects both natural and recombinant human TGF β 1. The cross-reactivity of TGF β 2 and TGF β 3, and of TNF β , IL-8, IL-6, IL-2, TNF α , IL-1 β , IL-4, IFN γ , IL-12p70, IL-5, and IL-10 was evaluated by spiking these proteins at physiologically relevant concentrations into serum. No cross-reactivity was detected.

Expected values

A panel of samples from randomly selected apparently healthy donors (males and females) was tested for human TGF β 1.

Sample matrix	Number of samples evaluated	Range (pg/mL)	Mean (pg/mL)	Standard deviation (pg/mL)
Serum	16	5,222-13,731	6,723	1,978
Plasma (EDTA)	40	0-2,644	729	389
Plasma (citrate)	40	908-3,378	1,726	578
Plasma (heparin)	40	0-377	46	96

Reagent preparation summary

Wash buffer (1x)

Add Wash Buffer Concentrate 20x (50 mL) to 950 mL distilled water.

Number of Strips	Wash Buffer Concentrate (mL)	Distilled Water (mL)
1 - 6	25	475
1 - 12	50	950

Assay buffer (1x)

Add Assay Buffer Concentrate 20x (5 mL) to 95 mL distilled water.

Number of Strips	Assay Buffer Concentrate (mL)	Distilled Water (mL)
1 - 6	2.5	47.5
1 - 12	5.0	95.0

Biotin-Conjugate

Make a 1:100 dilution of Biotin-Conjugate in Assay Buffer (1x):

Number of Strips	Biotin-Conjugate (mL)	Assay Buffer (1x) (mL)
1 - 6	0.06	5.94
1 - 12	0.12	11.88

Streptavidin-HRP

Make a 1:100 dilution of Streptavidin-HRP in Assay Buffer (1x):

Number of Strips	Streptavidin-HRP (mL)	Assay Buffer (1x) (mL)
1 - 6	0.06	5.94
1 - 12	0.12	11.88

Human TGF β 1 standard

Reconstitute lyophilized human TGF β 1 standard with distilled water. (Reconstitution volume is stated on the label of the standard vial.)

Test protocol summary

1. Pretreatment: 1:10 predilution (20 μL sample + 180 μL Assay Buffer (1x)), add 20 μL 1N HCl (see "Materials required but not provided" on page 2) to 200 μL prediluted sample, mix and incubate for 1 hour at room temperature, add 20 μL 1N NaOH (see "Materials required but not provided" on page 2) (Vortex!)
2. Determine the number of microwell strips required.
3. Wash microwell strips twice with Wash Buffer.
4. Standard dilution on the microwell plate: Add 100 μL Assay Buffer (1x), in duplicate, to all standard wells. Pipette 100 μL prepared standard into the first wells and create standard dilutions by transferring 100 μL from well to well. Discard 100 μL from the last wells.
Alternatively external standard dilution in tubes (see "External standard dilution" on page 3): Pipette 100 μL of these standard dilutions in the microwell strips.
5. Add 100 μL Assay Buffer (1x), in duplicate, to the blank wells.
6. Add 60 μL Assay Buffer (1x) to sample wells.
7. Add 40 μL sample in duplicate, to designated sample wells. (It is absolutely necessary to vortex the samples!)
8. Cover microwell strips and incubate 2 hours at room temperature (Shaking is absolutely necessary for an optimal test performance.)
9. Prepare Biotin-Conjugate.
10. Empty and wash microwell strips 5 times with Wash Buffer.
11. Add 100 μL Biotin-Conjugate to all wells.
12. Cover microwell strips and incubate 1 hour at room temperature. (Shaking is absolutely necessary for an optimal test performance.)
13. Prepare Streptavidin-HRP.
14. Empty and wash microwell strips 5 times with Wash Buffer.
15. Add 100 μL diluted Streptavidin-HRP to all wells.
16. Cover microwell strips and incubate 1 hour at room temperature. (Shaking is absolutely necessary for an optimal test performance.)
17. Empty and wash microwell strips 5 times with Wash Buffer.
18. Add 100 μL of TMB Substrate Solution to all wells.
19. Incubate the microwell strips for about 30 minutes at room temperature (18° to 25°C).
20. Add 100 μL Stop Solution to all wells.
21. Blank microwell reader and measure color intensity at 450 nm.

Note: If instructions in this protocol have been followed samples have been diluted 1:30 (20 μL sample + 180 μL Assay Buffer (1x) + 20 μL 1N HCl + 20 μL 1N NaOH and 40 μL pretreated sample + 60 μL Assay Buffer (1x)), the concentration read from the standard curve must be multiplied by the dilution factor ($\times 30$).

Customer and technical support

Visit thermofisher.com/support for the latest service and support information.

- Worldwide contact telephone numbers
- Product support information
 - Product FAQs
 - Software, patches, and updates
 - Training for many applications and instruments
- Order and web support
- Product documentation
 - User guides, manuals, and protocols
 - Certificates of Analysis
 - Safety Data Sheets (SDSs; also known as MSDSs)

Note: For SDSs for reagents and chemicals from other manufacturers, contact the manufacturer.

Limited product warranty

Life Technologies Corporation and/or its affiliate(s) warrant their products as set forth in the Life Technologies' General Terms and Conditions of Sale at www.thermofisher.com/us/en/home/global/terms-and-conditions.html. If you have any questions, please contact Life Technologies at www.thermofisher.com/support.



The information in this guide is subject to change without notice.

DISCLAIMER: TO THE EXTENT ALLOWED BY LAW, THERMO FISHER SCIENTIFIC INC. AND/OR ITS AFFILIATE(S) WILL NOT BE LIABLE FOR SPECIAL, INCIDENTAL, INDIRECT, PUNITIVE, MULTIPLE, OR CONSEQUENTIAL DAMAGES IN CONNECTION WITH OR ARISING FROM THIS DOCUMENT, INCLUDING YOUR USE OF IT.

Important Licensing Information: These products may be covered by one or more Limited Use Label Licenses. By use of these products, you accept the terms and conditions of all applicable Limited Use Label Licenses.

©2018 Thermo Fisher Scientific Inc. All rights reserved. All trademarks are the property of Thermo Fisher Scientific and its subsidiaries unless otherwise specified. All other trademarks are the property of their respective owners.