

JEWETT

LR and PR Series

**Laboratory and Pharmacy
Refrigerators**

Installation and Operation Manual



LABORATORY & PHARMACY REFRIGERATORS

This *JEWETT* Product is a complete packaged unit ready to operate when plugged into an electrical source. It is not necessary to have a refrigeration serviceman set the unit in operation. The unit has been tested prior to shipment. Read all the instructions before proceeding with installation.

INSPECTION FOR DAMAGE

Uncrate the product and remove all packing and crating materials. Inspect the product and parts thoroughly for damage or missing parts. File all claims for damage with the transportation company immediately. Do not file claims with the manufacturer.

INSTALLATION INSTRUCTIONS

1. Measure all doorways and passageways for clearance before moving cabinet. Model sizes 17 and 37 will pass through 30" X 84" door openings. Model sizes 25 and 55 will pass through 36" X 84" door openings. If additional clearance is needed, remove the condensate evaporator assembly, channel guards and drain tube from the back of the cabinet. To remove the drain tube, detach the rubber tube located below the unit cooler inside the refrigerator. With a slight twisting motion, pull drain tube from the back of the cabinet. Do not disconnect wiring on condensate evaporator. Flexible armored cable will permit sufficient movement to swing assembly to top or side of unit.
2. Inspect the interior, exterior and mechanical equipment for special instruction tags fastened at various points.
3. Move the refrigerator into the desired location. Make sure the bottom of the refrigerator is evenly supported. Thin shims under the points of rest can be used to equalize the distribution of weight. If the cabinet sets on an uneven floor, a slight rocking or vibration might result when the condensing unit is set in operation.
4. A minimum of 8" clearance is required between the ceiling and the top of the refrigerator, and a minimum of 3" clearance is required at the rear to allow adequate ventilation of the mechanical equipment.
5. The condensing unit is shipped with all service valves open and ready for operation. Do not adjust the refrigerant valves or the temperature control.
6. The unit is set to operate on either a 120/60/1 or 230/50/1 alternating current. Consult the unit's serial tag to determine the proper voltage. Use of any other electrical characteristics will cause permanent damage to the mechanism.
7. All models have been provided with an electric condensate evaporator located on the back of the cabinet. Periodic cleaning of the condensate pan will insure proper operation. CAUTION: Pan and heater are hot.
8. Operate the refrigerator for several hours to allow the unit to reach normal operating temperatures before storing product. Erratic operation on initial start-up does not

indicate a faulty control. When normal operating temperature is reached, the condensing unit will cycle regularly.

MAINTENANCE INSTRUCTIONS

1. Frequent cleaning of the interior and exterior with water and a good fungicidal detergent that eliminates harmful bacteria, stains and other foreign matter, will keep the unit fresh and new looking.
2. Shelves and/or drawers should be removed from the cabinet and thoroughly scrubbed. Clean door gasket periodically.
3. The unit cooler fan operates continuously when the door is closed and requires no lubrication. These models require no manual defrosting. The cooling coil automatically defrosts when the condensing unit is on the off cycle.
4. The condensing unit needs no oil or other lubrication. The finned condenser can become clogged with lint or dust. The openings between the fins should be kept clean. A vacuum cleaner or small test tube brush works well for this purpose. This should be accomplished on an annual basis. Failure to keep the condenser fins free of dirt and lint will result in erratic operation and may damage the refrigeration system.
5. Annual inspection of the mechanical refrigeration equipment by a qualified serviceman is recommended. A qualified mechanic can frequently make adjustments that will prevent future breakdown.
6. The refrigeration system is charged with refrigerant R134a. If the system is opened for any reason, extreme care should be taken to prevent the entry of moisture-bearing air. A new drier should be installed in the lines when the system is closed.

TEMPERATURE CONTROL

This refrigerator uses a Dixell XR60 temperature control:

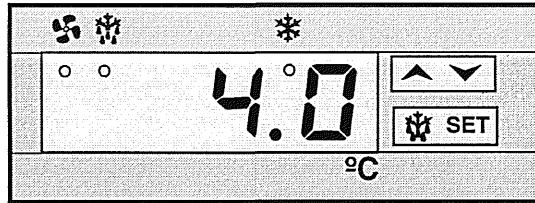

Control operation is described in detail on the following three insert pages.

Digital controller with defrost and fans management

XR60C

CONTENTS

1. GENERAL WARNING 1

2. GENERAL DESCRIPTION 1

3. CONTROLLING LOADS 1

4. FRONT PANEL COMMANDS 1

5. TEMPERATURE ALARM AND ITS DURATION RECORDING (HACCP) 1

6. MAIN FUNCTIONS 2

7. PARAMETERS 2

8. DIGITAL INPUT 3

9. INSTALLATION AND MOUNTING 3

10. ELECTRICAL CONNECTIONS 3

11. HOW TO USE THE HOT KEY 3

12. ALARM SIGNALS 4

13. TECHNICAL DATA 4

14. CONNECTIONS 4

15. DEFAULT SETTING VALUES 4

1. GENERAL WARNING

1.1 PLEASE READ BEFORE USING THIS MANUAL

- This manual is part of the product and should be kept near the instrument for easy and quick reference.
- The instrument shall not be used for purposes different from those described hereunder. It cannot be used as a safety device.
- Check the application limits before proceeding.

1.2 SAFETY PRECAUTIONS

- Check the supply voltage is correct before connecting the instrument.
- Do not expose to water or moisture: use the controller only within the operating limits avoiding sudden temperature changes with high atmospheric humidity to prevent formation of condensation
- Warning: disconnect all electrical connections before any kind of maintenance.
- Fit the probe where it is not accessible by the End User. The instrument must not be opened.
- In case of failure or faulty operation send the instrument back to the distributor or to "Dixell s.r.l." (see address) with a detailed description of the fault.
- Consider the maximum current which can be applied to each relay (see Technical Data).
- Ensure that the wires for probes, loads and the power supply are separated and far enough from each other, without crossing or intertwining.
- In case of applications in industrial environments, the use of mains filters (our mod. FT1) in parallel with inductive loads could be useful.

2. GENERAL DESCRIPTION

Model XR60C, 32x74 mm format, is a microprocessor based controller, suitable for applications on medium or low temperature ventilated refrigerating units. It has three relay outputs to control compressor, fan, and defrost, which can be either electrical or reverse cycle (hot gas). It is also provided with two NTC or PTC probe inputs, one for temperature control, the other, to be located onto the evaporator, to control the defrost termination temperature and to managed the fan. The instrument is fully configurable through special parameters that can be easily programmed through the keyboard.

3. CONTROLLING LOADS

3.1 COMPRESSOR

The regulation is performed according to the temperature measured by the thermostat probe with a positive differential from the set point: if the temperature increases and reaches set point plus differential the compressor is started and then turned off when the temperature reaches the set point value again.

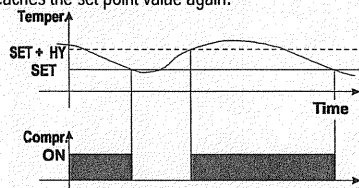

In case of fault in the thermostat probe the start and stop of the compressor are timed through parameters "CO_n" and "CO_F".

3.2 DEFOST

Two defrost modes are available through the "tdF" parameter: defrost through electrical heater (tdF = EL) and hot gas defrost (tdF = in). Other parameters are used to control the interval between defrost cycles (ldF), its maximum length (MdF) and two defrost modes: timed or controlled by the evaporator's probe (P2P).

At the end of defrost dripping time is started, its length is set in the FSt parameter. With FSt = 0 the dripping time is disabled.

3.3 CONTROL OF EVAPORATOR FANS

The fan control mode is selected by means of the "FnC" parameter:

- FnC = C_n**: fans will switch ON and OFF with the compressor and **not run** during defrost;
- FnC = o_n**: fans will run even if the compressor is off, and not run during defrost; After defrost, there is a timed fan delay allowing for drip time, set by means of the "Fnd" parameter.
- FnC = C_Y**: fans will switch ON and OFF with the compressor and **run** during defrost;
- FnC = o_Y**: fans will run continuously also during defrost

An additional parameter "FSt" provides the setting of temperature, detected by the evaporator probe, above which the fans are always OFF. This is used to make sure circulation of air only if his temperature is lower than set in "FSt".

3.3.1 Forced activation of fans

This function managed by the Fct parameter is designed to avoid short cycles of fans, that could happen when the controller is switched on or after a defrost, when the room air warms the evaporator.

Functioning: if the difference of temperature between the evaporator and the room probes is more than the value of the Fct parameter, the fans are switched on. With Fct=0 the function is disabled.

4. FRONT PANEL COMMANDS

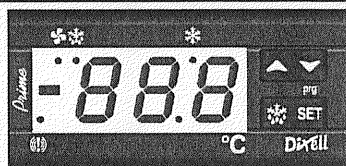

SET: To display target set point; in programming mode it selects a parameter or confirm an operation.

❄ (DEF) To start a manual defrost

- ▲ (UP):** To see the last temperature alarm happened; in programming mode it browses the parameter codes or increases the displayed value.
- ▼ (DOWN)** To see the last temperature alarm happened; in programming mode it browses the parameter codes or decreases the displayed value.

KEY COMBINATIONS:

- ▲ + ▼** To lock & unlock the keyboard.
- SET + ▼** To enter in programming mode.
- SET + ▲** To return to the room temperature display.

4.1 USE OF LEDS

Each LED function is described in the following table.

LED	MODE	FUNCTION
❄	ON	Compressor enabled
❄	Flashing	- Programming Phase (flashing with ❄) - Anti-short cycle delay enabled
❄	ON	Defrost enabled
❄	Flashing	- Programming Phase (flashing with ❄) - Drip time in progress
🌀	ON	Fans enabled
🌀	Flashing	Fans delay after defrost in progress.
🔊	ON	An temperature alarm happened

5. TEMPERATURE ALARM AND ITS DURATION RECORDING (HACCP)

XR60C signals and records temperature alarms, together with their duration and max value reached. See drawing:

Ex. High temperature alarm

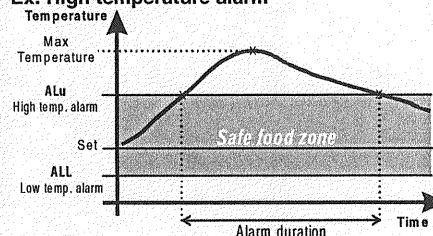

5.1 HOW TO SEE THE ALARM DURATION AND MAX (MIN) TEMPERATURE

If the alarm LED is on, an alarm has taken place.

To see the kind of alarm, the max (min) reached temperature and alarm duration do as follows:

1. Push the Up or Down key.
2. On the display the following message is shown:
"HAL" for high temperature alarm ("LAL" for the minimum alarm), followed by the **Maximum (minimum) temperature**.
Then the "tIm" (time) message is displayed, followed by the "Duration" in h.mm.
3. Then the instrument displays the temperature once again.

NOTE1: if an alarm is still occurring the "tIm" shows the partial duration.

NOTE2: the alarm is recorded when the temperature come back to normal values

5.2 HOW TO RESET A RECORDED ALARM OR ONE THAT IS STILL OCCURRING

1. Hold the SET key pressed for more than 3s, while the recorded alarm is displayed. (the rSt message will be displayed)
2. To confirm the operation, the "rSt" message starts blinking and the normal temperature will be displayed.

6. MAIN FUNCTIONS**6.1 HOW TO SEE THE SETPOINT**

- SET** 
1. Push and immediately release the SET key: the display will show the Set point value;
 2. Push and immediately release the SET key or wait for 5 seconds to display the probe value again.

6.2 HOW TO CHANGE THE SETPOINT

1. Push the SET key for more than 2 seconds to change the Set point value;
2. The value of the set point will be displayed and the * LED starts blinking;
3. To change the Set value push the ^ or v arrows within 10s.
4. To memorise the new set point value push the SET key again or wait 10s.

6.3 HOW TO START A MANUAL DEFROST

-  Push the DEF key for more than 2 seconds and a manual defrost will start.

6.4 HOW TO CHANGE A PARAMETER VALUE

To change the parameter's value operate as follows:

- 
1. Enter the Programming mode by pressing the Set and DOWN key for 3s (* and * start blinking).
 2. Select the required parameter.
 3. Press the "SET" key to display its value (now only the * LED is blinking).

- 
4. Use "UP" or "DOWN" to change its value.
 5. Press "SET" to store the new value and move to the following parameter.

To exit: Press SET + UP or wait 15s without pressing a key.

NOTE: the set value is stored even when the procedure is exited by waiting the time-out to expire.

6.5 THE HIDDEN MENU

The hidden menu includes all the parameters of the instrument.

6.5.1 HOW TO ENTER THE HIDDEN MENU

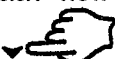
- 
1. Enter the Programming mode by pressing the Set + v key for 3s (LED 1 and * start blinking).
 2. When a parameter is displayed keep pressed the Set + v for more than 7s.
The Pr2 label will be displayed immediately followed from the HY parameter. **NOW YOU ARE IN THE HIDDEN MENU.**

- 
3. Select the required parameter.
 4. Press the "SET" key to display its value (Now only the * LED is blinking).
 5. Use ^ or v to change its value.
 6. Press "SET" to store the new value and move to the following parameter.

To exit: Press SET + ^ or wait 15s without pressing a key.

NOTE: the set value is stored even when the procedure is exited by waiting the time-out to expire.

6.5.2 HOW TO MOVE A PARAMETER FROM THE HIDDEN MENU TO THE FIRST LEVEL AND VICEVERSA.

Each parameter present in the HIDDEN MENU can be removed or put into "THE FIRST LEVEL" (user level) by pressing "SET + v".

In HIDDEN MENU when a parameter is present in First Level the decimal point is on.

6.6 HOW TO LOCK THE KEYBOARD

1. Keep pressed for more than 3 s the UP and DOWN keys.
2. The "POF" message will be displayed and the keyboard will be locked. At this point it will be possible only to see the set point or the MAX o Min temperature stored
3. If a key is pressed more than 3s the "POF" message will be displayed.

6.7 TO UNLOCK THE KEYBOARD

Keep pressed together for more than 3s the ^ and v keys, till the "Pon" message will be displayed.

6.8 THE CONTINUOUS CYCLE

 When defrost is not in progress, it can be activated by holding the " ^ " key pressed for about 3 seconds.

The compressor operates in continuous mode for the time set through the "CCt" parameter. The cycle can be terminated before the end of the set time using the same activation key " ^ " for 3 seconds.

7. PARAMETERS

NOTE: the parameters preceded by dots are in the Hidden Menu.

REGULATION

Hy Differential: (0,1 ÷ 25,5°C / 1÷255 °F) Intervention differential for set point. Compressor Cut IN is Set Point Plus Differential (Hy). Compressor Cut OUT is when the temperature reaches the set point.

- **LS Minimum set point:** (- 50°C÷SET/-58°F÷SET); Sets the minimum acceptable value for the set point.
- **US Maximum set point:** (SET÷110°C/ SET÷230°F). Set the maximum acceptable value for set point.

Ot Thermostat probe calibration: (-12,0÷12,0°C; -120÷120°F) allows to adjust possible offset of the thermostat probe.

P2P Evaporator probe presence: n= not present: the defrost stops by time; y= present: the defrost stops by temperature.

- **OE Evaporator probe calibration:** (-12,0÷12,0°C; -120÷120°F). allows to adjust possible offset of the evaporator probe.

- **OdS Outputs activation delay at start up:** (0÷255min) This function is enabled at the initial start up of the instrument and inhibits any output activation for the period of time set in the parameter.

AC Anti-short cycle delay: (0÷50 min) minimum interval between the compressor stop and the following restart.

- **CCt Compressor ON time during continuous cycle:** (0,0÷24,0h; res. 10min) Allows to set the length of the continuous cycle: compressor stays on without interruption for the CCt time. Can be used, for instance, when the room is filled with new products.
- **COt Compressor ON time with faulty probe:** (0÷255 min) time during which the compressor is active in case of faulty thermostat probe. With COt=0 compressor is always OFF.
- **COF Compressor OFF time with faulty probe:** (0÷255 min) time during which the compressor is OFF in case of faulty thermostat probe. With COF=0 compressor is always active.

DISPLAY

- **CF Temperature measurement unit:**
°C=Celsius; °F=Fahrenheit. **WARNING:** When the measurement unit is changed the SET point and the values of the parameters Hy, LS, US, Ot, ALU and ALL have to be checked and modified if necessary).

rES Resolution (for °C): (in = 1°C; dE = 0.1 °C) allows decimal point display.

- **Lod Display :** select which probe is displayed by the instrument: P1 = Thermostat probe; P2 = Evaporator probe

DEFROST

tdF Defrost type: EL = electrical heater; in = hot gas

dtE Defrost termination temperature: (-50÷50 °C/ -58÷122°F) (Enabled only when EdF=Pb) sets the temperature measured by the evaporator probe, which causes the end of defrost.

ldF Interval between defrost cycles: (0÷120h) Determines the time interval between the beginning of two defrost cycles.

mdF (Maximum) length for defrost: (0÷255min) When P2P = n, (not evaporator probe: timed duration) it sets the defrost duration, when P2P = y (defrost end based on temperature) it sets the maximum length for defrost.

- **dSd Start defrost delay:** (0÷99min) This is useful when different defrost start times are necessary to avoid overloading the plant.

- **dFd Temperature displayed during defrost:** (rt = real temperature; it = temperature at defrost start; SET = set point; dEF = "dEF" label)

- **dAd MAX display delay after defrost:** (0÷255min). Sets the maximum time between the end of defrost and the restarting of the real room temperature display.

- **Fdt Drip time:** (0÷120 min) time interval between reaching defrost termination temperature and the restoring of the control's normal operation. This time allows the evaporator to eliminate water drops that might have formed due to defrost.

- **dPo** First defrost after start-up: (y = immediately; n = after the IdF time)
- **dAF** Defrost delay after continuous cycle: (0÷23.5h) time interval between the end of the fast freezing cycle and the following defrost related to it.

FANS

- FnC Fans operating mode:** C-n = runs with the compressor, OFF during defrost;
 o-n = continuous mode, OFF during defrost;
 C-Y = runs with the compressor, ON during defrost;
 o-Y = continuous mode, ON during defrost;
- Fnd Fans delay after defrost:** (0÷255min) Time interval between end of defrost and evaporator fans start.
- Fct Temperature differential avoiding short cycles of fans** (0÷59°C; Fct=0 function disabled). If the difference of temperature between the evaporator and the room probes is more than the value of the Fct parameter, the fans are switched on.
- FSt Fans stop temperature:** (-50÷50°C/122°F) setting of temperature, detected by evaporator probe, above which fans are always OFF.

ALARMS

- **ALC Temperature alarms configuration:** (Ab; rE)
 Ab= absolute temperature: alarm temperature is given by the ALL or ALU values.
 rE = temperature alarms are referred to the set point. Temperature alarm is enabled when the temperature exceeds the "SET+ALU" or "SET-ALL" values.
- ALU MAXIMUM temperature alarm:** (SET÷110°C; SET÷230°F) when this temperature is reached the alarm is enabled, after the "ALd" delay time.
- ALL Minimum temperature alarm:** (-50.0 ÷ SET°C; -58÷230°F) when this temperature is reached the alarm is enabled, after the "ALd" delay time.
- **ALd Temperature alarm delay:** (0÷255 min) time interval between the detection of an alarm condition and alarm signalling.
- **dAO Exclusion of temperature alarm at startup:** (from 0.0 min to 23.5h) time interval between the detection of the temperature alarm condition after instrument power on and alarm signalling.

DIGITAL INPUT

i1P Digital input polarity: oP: the digital input is activated by opening the contact; CL: the digital input is activated by closing the contact.

i1F Digital input configuration:

EAL = external alarm: "EA" message is displayed; bAL = serious alarm "CA" message is displayed. PAL = pressure switch alarm, "CA" message is displayed; dor = door switch function; dEF = activation of a defrost cycle; LHT = not enabled; Htr = kind of action inversion (cooling - heating).

did: (0÷255 min)

with i1F= EAL or i1F = bAL digital input alarm delay: delay between the detection of the external alarm condition and its signalling.

with i1F= dor: door open signalling delay

with i1F = PAL: time for pressure switch function: time interval to calculate the number of the pressure switch activation.

nPS Pressure switch number: (0 ÷15) Number of activation of the pressure switch, during the "did" interval, before signalling the alarm event (i2F= PAL).

If the nPS activation in the did time is reached, switch off and on the instrument to restart normal regulation.

- **odc** Compressor and fan status when open door: no = normal; Fan = Fan OFF; CPr = Compressor OFF; F_C = Compressor and fan OFF.

OTHER

PbC Type of probe: it allows to set the kind of probe used by the instrument: PbC = PBC probe, ntC = NTC probe.

- **dP1** First probe display
- **dP2** Second probe display
- **rEL** Software release for internal use.
- **Ptb** Parameter table code: readable only.

8. DIGITAL INPUT

The free contact digital input is programmable in five different configurations by the "i1F" parameter.

8.1 DOOR SWITCH INPUT (i1F = dor)

It signals the door status and the corresponding relay output status through the "odc" parameter:

- no = normal (any change);
- Fan = Fan OFF;
- CPr = Compressor OFF;
- F_C = Compressor and fan OFF.

Since the door is opened, after the delay time set through parameter "did", the door alarm is enabled, the display shows the message "dA" and the regulation restarts. The alarm stops as soon as the external digital input is disabled again. With the door open, the high and low temperature alarms are disabled.

8.2 GENERIC ALARM (i1F = EAL)

As soon as the digital input is activated the unit will wait for "did" time delay before signalling the "EAL" alarm message. The outputs status don't change. The alarm stops just after the digital input is de-activated.

8.3 SERIOUS ALARM MODE (i1F = bAL)

When the digital input is activated, the unit will wait for "did" delay before signalling the "CA" alarm message. The relay outputs are switched OFF. The alarm will stop as soon as the digital input is de-activated.

8.4 PRESSURE SWITCH (i1F = PAL)

If during the interval time set by "did" parameter, the pressure switch has reached the number of activation of the "nPS" parameter, the "CA" pressure alarm message will be displayed. The compressor and the regulation are stopped. When the digital input is ON the compressor is always OFF.

If the nPS activation in the did time is reached, switch off and on the instrument to restart normal regulation.

8.5 START DEFROST (i1F = dFr)

It starts a defrost if there are the right conditions. After the defrost is finished, the normal regulation will restart only if the digital input is disabled otherwise the instrument will wait until the "MdF" safety time is expired.

8.6 INVERSION OF THE KIND OF ACTION: HEATING-COOLING (i1F = Htr)

This function allows to invert the regulation of the controller: from cooling to heating and viceversa.

8.7 DIGITAL INPUTS POLARITY

The digital input polarity depends on the "i1P" parameter.

i1P=CL: the input is activated by closing the contact.

i1P=OP: the input is activated by opening the contact

9. INSTALLATION AND MOUNTING

Instrument XR60C shall be mounted on vertical panel, in a 29x71 mm hole, and fixed using the special bracket supplied.

To obtain an IP65 protection grade use the front panel rubber gasket (mod. RG-C) as shown in figure.

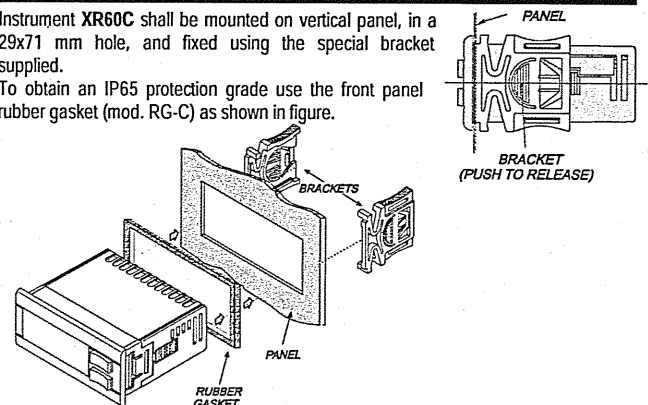

The temperature range allowed for correct operation is 0÷60 °C. Avoid places subject to strong vibrations, corrosive gases, excessive dirt or humidity. The same recommendations apply to probes. Let air circulate by the cooling holes.

10. ELECTRICAL CONNECTIONS

The instrument is provided with screw terminal block to connect cables with a cross section up to 2,5 mm². Before connecting cables make sure the power supply complies with the instrument's requirements. Separate the probe cables from the power supply cables, from the outputs and the power connections. Do not exceed the maximum current allowed on each relay, in case of heavier loads use a suitable external relay.

10.1 PROBE CONNECTION

The probes shall be mounted with the bulb upwards to prevent damages due to casual liquid infiltration. It is recommended to place the thermostat probe away from air streams to correctly measure the average room temperature. Place the defrost termination probe among the evaporator fins in the coldest place, where most ice is formed, far from heaters or from the warmest place during defrost, to prevent premature defrost termination.

11. HOW TO USE THE HOT KEY**11.1 HOW TO PROGRAM A HOT KEY FROM THE INSTRUMENT (UPLOAD)**

1. Program one controller with the front keypad.
2. When the controller is ON, insert the "Hot key" and push \blacktriangle key; the "uPL" message appears followed a by flashing "End"
3. Push "SET" key and the End will stop flashing.
4. Turn OFF the instrument remove the "Hot Key", then turn it ON again.

NOTE: the "Err" message is displayed for failed programming. In this case push again \blacktriangle key if you want to restart the upload again or remove the "Hot key" to abort the operation.

11.2 HOW TO PROGRAM AN INSTRUMENT USING A HOT KEY (DOWNLOAD)

1. Turn OFF the instrument.
2. Insert a programmed "Hot Key" into the 5 PIN receptacle and then turn the Controller ON.
3. Automatically the parameter list of the "Hot Key" is downloaded into the Controller memory, the "doL" message is blinking followed a by flashing "End".
4. After 10 seconds the instrument will restart working with the new parameters.
5. Remove the "Hot Key"..

NOTE the message "Err" is displayed for failed programming. In this case turn the unit off and then on if you want to restart the download again or remove the "Hot key" to abort the operation.

12. ALARM SIGNALS

Message	Cause	Outputs
"P1"	Room probe failure	Compressor output according to par. "Con" and "COF"
"P2"	Evaporator probe failure	Defrost end is timed
"HA"	Maximum temperature alarm	Outputs unchanged.
"LA"	Minimum temperature alarm	Outputs unchanged.
"dA"	Door open	Compressor and fans restarts
"EA"	External alarm	Output unchanged.
"CA"	Serious external alarm (i1F=bAL)	All outputs OFF.
"cA"	Pressure switch alarm (i1F=PAL)	All outputs OFF

12.1 ALARM RECOVERY

Probe alarms "P1" and "P2" start some seconds after the fault in the related probe; they automatically stop some seconds after the probe restarts normal operation. Check connections before replacing the probe.
 Temperature alarms "HA" and "LA" automatically stop as soon as the thermostat temperature returns to normal values and when defrost starts.
 Alarms "EA" and "CA" (with i1F=bAL) recover as soon as the digital input is disabled.
 Alarm "cA" (with i1F=PAL) recovers only by switching off and on the instrument.

13. TECHNICAL DATA

Housing: self extinguishing ABS.
Case: XR60C frontal 32x74 mm; depth 60mm;
Mounting: XR60C panel mounting in a 71x29mm panel cut-out
Protection: IP20; **Frontal protection:** IP65 with frontal gasket RG-C (optional).
Connections: Screw terminal block ≤ 2,5 mm² wiring.
Power supply: according to the model: 12Vac/dc, ±10%; 24Vac/dc, ±10%; 230Vac ±10%, 50/60Hz, 110Vac±10%, 50/60Hz
Power absorption: 3VA max
Display: 3 digits, red LED, 14,2 mm high.
Inputs: 2 NTC or PTC probes.
Digital input: free contact
Relay outputs
 compressor: SPST relay 8(3) A, 250Vac or SPST relay 16(6)A; 250Vac
 defrost: SPDT relay 8(3) A, 250Vac
 fan: SPST relay 8(3) A, 250Vac
Data storing: on the non-volatile memory (EEPROM).
Kind of action: 1B; **Pollution grade:** normal; **Software class:** A.
Operating temperature: 0÷60 °C; **Storage temperature:** -30÷85 °C.
Relative humidity: 20÷85% (no condensing)
Measuring and regulation range: NTC probe: -40÷110°C (-40÷230°F);
 PTC probe: -50÷150°C (-58÷302°F)
Resolution: 0,1 °C or 1°C or 1 °F (selectable).
Accuracy (ambient temp. 25°C): ±0,7 °C ±1 digit

14. CONNECTIONS

14.1 XR60C - 12VAC/DV OR 24 VAC/DV

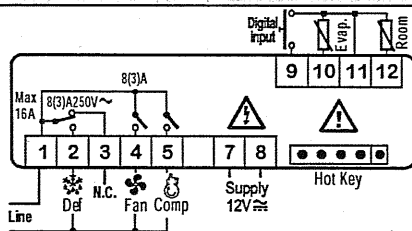

NOTE: The compressor relay is 8(3)A or 16(6)A according to the model.
24Vac/dc supply: connect to the terminals 7 and 8.

14.2 XR60C - 120VAC OR 230 VAC

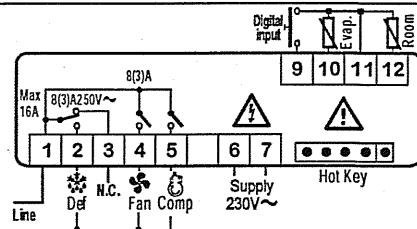

NOTE: The compressor relay is 8(3)A or 16(6)A according to the model.
120Vac supply: connect to the terminals 6 and 7.

15. DEFAULT SETTING VALUES

Label	Name	Range	°C/°F
Set	Set point	LS÷US	-5/0
Hy	Differential	0,1÷25,5°C/1÷ 255°F	2/4
LS	Minimum set point	-50°C÷SET/-58°F÷SET	-50/-58
US	Maximum set point	SET÷110°C/SET÷ 230°F	110/230
Ot	Thermostat probe calibration	-12÷12°C/-120÷120°F	0
P2P	Evaporator probe presence	n=not present; Y=pres.	y
OE	Evaporator probe calibration	-12÷12°C/-120÷120°F	0
OdS	Outputs delay at start up	0÷255 min	0
AC	Anti-short cycle delay	0 ÷ 50 min	1
CCt	Continuous cycle duration	0,0÷24,0h	0,0
COn	Compressor ON time with faulty probe	0 ÷ 255 min	15
COF	Compressor OFF time with faulty probe	0 ÷ 255 min	30
CF	Temperature measurement unit	°C ÷ °F	°C/°F
rES	Resolution	in=integer; dE= dec.point	dE/-
Lod	Probe displayed	P1;P2	P1
tdF	Defrost type	EL=el. heater; in= hot gas	EL
dTE	Defrost termination temperature	-50 ÷ 50 °C	8/46
IdF	Interval between defrost cycles	1 ÷ 120 ore	6
MdF	(Maximum) length for defrost	0 ÷ 255 min	30
dSD	Start defrost delay	0÷99min	0
dFd	Displaying during defrost	rt, R, SEt, DEF	it
dAd	MAX display delay after defrost	0 ÷ 255 min	30
Fdt	Draining time	0÷120 min	0
dPo	First defrost after startup	n=after IdF; y=immed.	n
dAF	Defrost delay after fast freezing	0 ÷ 23h e 50'	0,0
Fnc	Fan operating mode	C-n, o-n, C-y, o-Y	o-n
Fnd	Fan delay after defrost	0÷255min	10
Fct	Differential of temperature for forced activation of fans	0÷50°C	10
FSt	Fan stop temperature	-50÷50°C/-58÷ 122°F	2/35
ALc	Temperat. alarms configuration	rE= related to set; Ab= absolute	Ab
ALU	MAXIMUM temperature alarm	Set÷110,0°C; Set÷230°F	110/230
ALL	Minimum temperature alarm	-50,0°C÷SeL/-58°F÷Set	-50/-58
ALd	Temperature alarm delay	0 ÷ 255 min	15
dAO	Delay of temperature alarm at start up	0 ÷ 23h e 50'	1,30
i1P	Digital input polarity	oP=opening;CL=closing	CL
i1F	Digital input configuration	EAL=extern. alarm; bAL=lock regulation; PAL=press. switch; dor=door switch; dEF=defrost; LHt=disabled; Htr= heating-cooling	dor
did	Digital input alarm delay	0÷255min	15
Nps	Number of activation of pressure switch	0 ÷ 15	15
odc	Compressor and fan status when open door.	no = normal; Fan = Fan OFF; CPt = Compr. OFF; F_C = Compr & fan OFF.	F-C
PbC	Kind of probe	Ptc; ntc	ntc/Ptc
dP1	Room probe display	-	-
dP2	Evaporator probe display	-	-
rEL	Software release	-	2,7
Ptb	Map code	-	-

Hidden parameters



Dixell s.r.l. Z.I. Via dell'Industria, 27
 32010 Pieve d'Alpago (BL) ITALY
 tel. +39 - 0437 - 98 33 - fax +39 - 0437 - 98 93 13
 E-mail: dixell@dixell.com - http://www.dixell.com

HINGE AND LATCH ADJUSTMENT

HINGE ADJUSTMENT

1. Remove exterior hinge cover plate by opening the refrigerator door. Place a screwdriver under interior portion of cover and gently pry cover outward. Pull straight out. Close cover.
2. Loosen the three (3) screws "B" which hold adjusting plate "C" in position.
3. To tighten gasket seal, place hand against exterior of door near hinges; gently press in on door so gasket sits firmly against cabinet face. Tighten screws "B".
4. When adjustment is complete, if hinges are adjusted so gasket seal is too tight, door will tend to spring open. Door must be readjusted. To test gasket seal - insert a dollar bill (or piece of paper of similar size) between the gasket and the cabinet opening; close door - a slight resistance to removal of the dollar bill (test strip) should be felt - check perimeter of door. If latch is loose, see latch-adjusting information.
5. Replace cover plate "A"

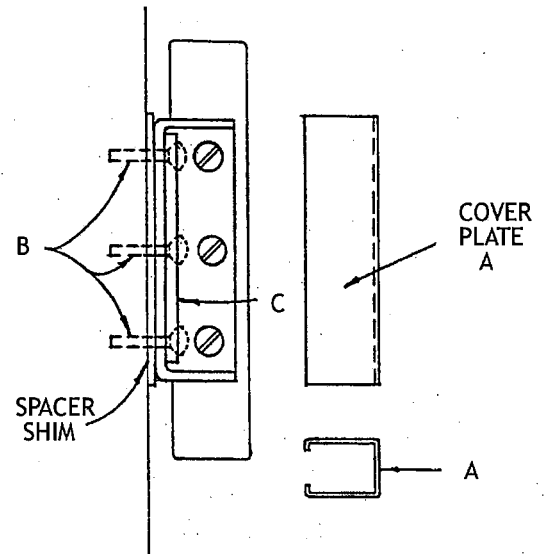

- NOTE: To accomplish different offsets, shims are utilized. If replacing hinges, make sure to reuse any shims furnished on the cabinet.

LATCH & STRIKE ADJUSTMENT

1. Latch as fastened to door.
2. For up or down adjustment (proper latch engagement,) loosen mounting screws "B".
3. Strike plate "C" remains in position.
4. Move strike "D" up or down as required and tighten screws "B" when adjustment is satisfactory. No play will be present in the latch handle with the door closed.
5. For in and out adjustment (proper gasket seal) loosen screw "E". Adjust in or out as required and tighten screw when adjustment is satisfactory.
6. The stainless steel hex head cap screw is 10/32" X 5/16" long, or use JEWETT part number BLT03C02A006. Use box wrench, open-end wrench, or ratchet to tighten. Do not use a nut driver or pliers.

- NOTE: If replacing latch and strike assembly, make sure to reuse any shims furnished on the cabinet.

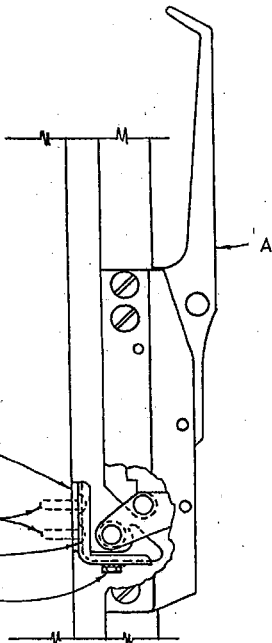

TROUBLESHOOTING SERVICE CHART

	SYMPTOM	POSSIBLE CAUSE	POSSIBLE CORRECTIVE STEP
A	Compressor will not start, no hum	1. Line disconnect switch open.	1. Close disconnect switch
		2. Fuse blown or breaker tripped.	2. Check electrical circuits and motor windings for shorts or grounds. Investigate for possible overloading. Replace fuse or reset breaker after fault is corrected.
		3. Thermal overload tripped.	3. Overloads are automatically reset. Check unit closely when compressor comes back on line.
		4. No cooling required	4. None. Wait until control calls for cooling.
		5. Control contacts stuck in open position.	5. Replace control.
		6. Loose wiring.	6. Check all wiring junctions, tighten all terminal screws.
		7. Improper wiring	7. Check wiring against diagram.
		8. Liquid line solenoid valve will not open.	8. Repair or replace solenoid coil
		9. Motor electrical trouble.	9. Check motor for open windings, Short circuit or burn out.
		10. Liquid line solenoid will not open.	10. Repair or replace coil.
B	Compressor will not start, hums but trips on thermal overload.	1. Low voltage to unit.	1. Determine reason and correct.
		2. Start capacitor failure or wrong.	2. Replace start capacitor.
		3. Run capacitor failure or wrong.	3. Replace run capacitor.
		4. Start relay failure or wrong.	4. Replace start relay.
		5. Motor electrical trouble.	5. Check motor for open windings, Short circuit or burn out.
		6. Internal mechanical trouble in compressor.	6. Replace compressor.
		7. Improper wiring	7. Check wiring against diagram.
		8. Excessively high discharge pressure.	8. See high discharge pressure symptom.
C	Compressor starts, but does not switch off of start winding.	1. Low voltage to unit.	1. Determine reason and correct.
		2. Run capacitor failure or wrong.	2. Replace run capacitor.
		3. Start capacitor failure or wrong.	3. Replace start capacitor.
		4. Start relay failure or wrong.	4. Replace start relay.
		5. Motor electrical trouble.	5. Check motor for open windings, Short circuit or burn out.
		6. Internal mechanical trouble in compressor.	6. Replace compressor.
		7. Improper wiring.	7. Check wiring against diagram.
		8. Excessively high discharge pressure.	8. See high discharge pressure symptom.

TROUBLESHOOTING SERVICE CHART

	SYMPTOM	POSSIBLE CAUSE	POSSIBLE CORRECTIVE STEP
D	Compressor starts and runs, but short cycles on overload protector.	1. Excessively high discharge pressure.	1. See high discharge pressure symptom.
		2. Low voltage to unit.	2. Determine reason and correct.
		3. High voltage to unit.	3. Determine reason and correct.
		4. Thermal overload protector defective.	4. Check current, Replace protector.
		5. Run capacitor failure or wrong.	5. Replace run capacitor.
		6. Motor electrical trouble.	6. Check motor for open windings, Short circuit or burn out.
		7. Improper wiring causing additional current to pass through overload protector.	7. Check wiring diagram. Check for added fan motors, heaters, etc., connected to wrong side of protector.
E	Compressor starts and runs, but short cycles on temperature or pressure controls.	1. Differential set too close.	1. Widen differential.
		2. High discharge pressure.	2. See high discharge pressure symptom.
		3. Low discharge pressure.	1. See low discharge pressure symptom.
F	Compressor runs long or continuously.	1. Shortage of refrigerant.	1. Leak check and repair.
		2. Control contacts stuck or frozen.	2. Clean contacts or replace control.
		3. Refrigerated air space has an excessive load.	3. Determine reason and correct.
		4. Dirty Condenser	4. Clean condenser.
		5. Evaporator coil iced.	5. Defrost and check defrost circuit.
		6. Restriction in refrigeration system.	6. Determine location and remove.
		7. Evaporator fan motors not running.	7. Determine reason and correct. Check door switch.
G	Compressor noisy or vibrating.	1. Flooding of refrigerant into crankcase.	1. Check expansion device and refrigerant charge.
		2. Improper piping support.	2. Relocate tubing or add hangers.
		3. Worn compressor.	3. Replace compressor.
		4. Loose parts or mounting.	4. Find and tighten.
		5. Condenser fan blade loose or impeded.	5. Check and repair.
H	High Discharge pressure.	1. Non-condensables in system.	1. Remove the non-condesables.
		2. System overcharged with refrigerant.	2. Correct the charge.
		3. Discharge shutoff valve partially closed.	3. Open valve.
		4. Condenser fans not running.	4. Check electrical circuit.
		5. Dirty condenser.	5. Clean.
I	Low discharge pressure.	1. Suction shutoff valve partially closed.	1. open valve.
		2. Insufficient refrigerant in system.	2. Check for leaks. Repair and add charge.
		3. Low suction pressure.	3. See low suction pressure symptom.

TROUBLESHOOTING SERVICE CHART

	SYMPTOM	POSSIBLE CAUSE	POSSIBLE CORRECTIVE STEP
J	High suction pressure.	1. Excessive load.	1. Reduce load or add additional equipment.
		2. Expansion valve overfeeding.	2. Check remote bulb. Adjust superheat.
K	Low suction pressure.	1. Insufficient refrigerant in system.	1. Check for leaks. Repair and add charge.
		2. Restriction in refrigeration system. Most notably the liquid line filter drier or capillary.	2. Determine location and remove.
		3. Expansion valve malfunctioning.	3. Check and reset for proper superheat.
L	Suction line frosted or sweating.	1. Expansion valve passing excess refrigerant or is oversized.	1. Readjust valve or replace with smaller valve.
		2. Expansion valve stuck open.	2. Clean valve of foreign particles, and replace if necessary.
		3. Evaporator fan motors not running.	3. Determine reason and correct. Check door switch.
		4. System overcharged with refrigerant.	4. Correct the charge.
M	Liquid line frosted or sweating	1. Restriction in liquid line filter drier.	1. Determine location and remove.
		2. Liquid line shutoff valve partially closed.	2. Open valve.
N	Ice accumulating on ceiling around evaporator and/or on fan guards or blades.	1. Defrost duration too long.	1. Adjust defrost termination.
		2. Fan delay not delaying fans after defrost period.	2. Defective fan delay thermostat. Replace.
		3. Defective timer.	3. Replace.
		4. Too many defrost cycles per day.	4. Adjust timer for less defrost cycles.
O	Evaporator coil not clearing of frost during defrost cycle.	1. Coil temperature not getting above freezing point during defrost.	1. Check heater operation, or hot gas solenoid valve.
		2. Not enough defrost cycles per day.	2. Adjust timer for more defrost cycles.
		3. Defrost cycle too short.	3. Adjust timer for longer defrost cycle.
		4. Poor door seal.	4. Adjust door latch, install new gasket.
		5. Defective timer or defrost thermostat.	5. Replace defective component.
P	Ice accumulating in drain pan.	1. Defective heater.	1. Replace heater.
		2. Unit not pitched properly.	2. Check and adjust if necessary.
		3. Drain line plugged.	3. Clean drain line.
		4. Defective drain line heater.	4. Replace heater.
		5. Poor contact between drain pan and heater element.	5. Repair.
		6. Defective timer or defrost thermostat.	6. Replace defective component.

NOTE: Jewett Refrigerators and Freezers are designed to operate in areas that are heated to 60° F (15.6° C). Installation in unheated areas may require a low temperature compressor protection kit for satisfactory operation.

5-2-1 WARRANTY

JEWETT Inc. is committed to supplying its customers with products of the highest quality. JEWETT ensures product performance by offering the following warranty on each new piece of equipment it manufactures (excluding products sold outside the 48 contiguous states, international sales and Polarstar Compact Refrigerators and Freezers for which our one year warranty on parts and workmanship applies).

For a period of five (5) years JEWETT will replace the refrigeration motor compressor if it is determined to be defective. This component will be supplied at no charge, including freight. JEWETT will not be liable for installation, refrigerant or miscellaneous charges required to install the motor compressor beyond the first year after equipment delivery.

For a period of two (2) years, JEWETT will supply at no charge, including freight, any replacement part that fails due to defects in material or workmanship under normal use. Inspection of defective parts by JEWETT will be final in determining warranty status. Defective parts must be returned, prepaid, with return authorization number to JEWETT.

For a period of one (1) year JEWETT will pay labor charges (including travel) and the cost of refrigerant and supplies necessary to perform authorized repairs to JEWETT products within the 48 contiguous United States. Repair service must be performed by a recommended JEWETT Service Agency. All service must be authorized by JEWETT prior to performance of same to be covered by this warranty. The following conditions apply:

1. JEWETT's warranty becomes effective two (2) weeks after shipment from our factory. This allows adequate shipping time so that commencement of the warranty coincides with delivery of your new equipment.
2. This warranty does not apply to products damaged in transit or by accident, fire, flood, acts of God, unauthorized alteration, repair or improper installation. JEWETT's warranties shall not be effective or actionable unless the equipment is used in accordance with all accompanying warnings and directions.
3. JEWETT shall not be liable for loss of stored product.
4. All service calls must be authorized by JEWETT prior to performance of same. If repeat calls are required, each must be authorized by JEWETT prior to performance of same. JEWETT retains the right to replace any product in lieu of servicing it in the field.
5. This warranty supersedes all other warranties, expressed or implied. JEWETT offers no warranty of merchantability or fitness for a particular purpose regarding goods sold. No agent, employee or representative of JEWETT Inc. may bind JEWETT to any warranty concerning equipment sold in addition to the warranty set forth above. Any warranty, affirmation or representation beyond the above terms and conditions shall be non-enforceable.

Please call 1-800-879-7767 to notify JEWETT of problems during the warranty period. To identify the product, please supply: Model Number - Serial Number - Full Description of Problem - Location of Product. The name of the designated JEWETT Service Agency will be supplied. Questions regarding operation, maintenance or product service may also be directed to the above toll-free number.

INTERNATIONAL WARRANTY

JEWETT Inc. warrants each new piece of equipment manufactured by us to be free from defects in material and workmanship under normal use and service for one year.

If any part of said equipment should show any defects in materials or workmanship within one year of installation by the original purchaser, we will be pleased to repair or replace such defective parts subject to the following conditions:

1. Installation must be made within 90 days from the date of shipment by JEWETT Inc., to the original purchaser.
2. The defective part shall be returned to us with transportation charges prepaid and the repaired or replaced part will be returned F.O.B. our factory.
3. Warranty does not include any labor charges for removal or replacement of defective parts or refrigerant.
4. This warranty will not apply to any equipment which has been repaired or altered outside of our factory without our specific authorization.
5. This warranty does not cover any loss of stored products.
6. This warranty supersedes all other warranties expressed or implied, and we neither assume nor authorize any other person to assume for us other liability in connection with the sale of our products.

WEEE Compliance

Great Britain



WEEE Compliance. This products is required to comply with the European Union's Waste Electrical & Electronic Equipment (WEEE) Directive 2002/96EC. It is marked with the following symbol. Thermo Scientific has contracted with one or more recycling/disposal companies in each EU Member State, and this products should be disposed of or recycling through them. Further information on Thermo Scientific's compliance with these Directives, the recyclers in your country, and information on Thermo Scientific products which may assist the detection of substances subject to the RoHS Directive are available at www.thermo.com/WEEERoHS

Deutschland



WEEE Konformität. Dieses Produkt muss die EU Waste Electrical & Electronic Equipment (WEEE) Richtlinie 2002/96EC erfüllen. Das Produkt ist durch folgendes Symbol gekennzeichnet. Thermo Scientific hat Vereinbarungen getroffen mit Verwertungs-/Entsorgungsanlagen in allen EU-Mitgliederstaaten und dieses Produkt muss durch diese Firmen wiederverwertet oder entsorgt werden. Mehr Informationen über die Einhaltung dieser Anweisungen durch Thermo Scientific, die Verwerter und Hinweise die Ihnen nützlich sein können, die Thermo Scientific Produkte zu identifizieren, die unter diese RoHS Anweisung fallen, finden Sie unter www.thermo.com/WEEERoHS

Italia



Conformità WEEE. Questo prodotto deve rispondere alla direttiva dell'Unione Europea 2002/96EC in merito ai Rifiuti degli Apparecchi Elettrici ed Elettronici (WEEE). È marcato col seguente simbolo. Thermo Scientific ha stipulato contratti con una o diverse società di riciclaggio/smaltimento in ognuno degli Stati Membri Europei. Questo prodotto verrà smaltito o riciclato tramite queste medesime. Ulteriori informazioni sulla conformità di Thermo Scientific con queste Direttive, l'elenco delle ditte di riciclaggio nel Vostro paese e informazioni sui prodotti Thermo Scientific che possono essere utili alla rilevazione di sostanze soggette alla Direttiva RoHS sono disponibili sul sito www.thermo.com/WEEERoHS

France



Conformité WEEE. Ce produit doit être conforme à la directive européenne (2002/96EC) des Déchets d'Equipements Electriques et Electroniques (DEEE). Il est marqué par le symbole suivant. Thermo Scientific s'est associé avec une ou plusieurs compagnies de recyclage dans chaque état membre de l'union européenne et ce produit devrait être collecté ou recyclé par celles-ci. Davantage d'informations sur la conformité de Thermo Scientific à ces directives, les recycleurs dans votre pays et les informations sur les produits Thermo Scientific qui peuvent aider le détection des substances sujettes à la directive RoHS sont disponibles sur www.thermo.com/WEEERoHS

Important

For your future reference and when contacting the factory, please have the following information readily available:

Model Number: _____

Serial Number: _____

Date Purchased: _____

The above information can be found on the dataplate attached to the equipment. If available, please provide the date purchased, the source of purchase (specific agent/rep organization), and purchase order number.

IF YOU NEED ASSISTANCE:

SALES DIVISION

Phone: 828/658-4455
800/879-7767

FAX: 828/645-0363

LABORATORY PARTS and SERVICE

Phone: 800/438-4851

FAX: 828/658-2576

TECHNICAL SUPPORT

Phone: 800/438-4851

WEB SITE: www.jewettonline.com

275 Aiken Road
Asheville, NC 28804
U.S.A.